

this drawing is property of Holland Lift International, by all rights reserved.  
 deze tekening is eigendom van Holland Lift International, by auteursrecht voorbehouden volgens de wet.  
 this drawing is property of Holland Lift International, by all rights reserved.  
 deze tekening is eigendom van Holland Lift International, by auteursrecht voorbehouden volgens de wet.

Optie/Option  
 Hatz Motor  
 Deutz Motor  
 Zie Blz 27  
 S. Blatt 27  
 See Page 27

Start Relais  
 Start Relais  
 Start Relay  
 M 2.2 | V

Oliedruk  
 te laag  
 Oelddruk  
 zu niedrig  
 Oilpressure  
 low

Temp.  
 Temp.  
 Temp.  
 Start Klep  
 Start Ventil  
 Start Valve

Toeren  
 hoog/laag  
 Drehzahl  
 hoch/niedrig  
 Engine Speed  
 high/Low

Luftfilter  
 Luftfilter  
 AIR - Filter

Koeler  
 Kuehler  
 Cooler

Koeler  
 Kuehler  
 Cooler

Vetpomp  
 Fett Pumpe  
 Grease Pump  
 Optie/Option  
 Zie Blz 24-26  
 S. Blatt 24-26  
 See Page 24-26

Frame Dieselmotor  
 Frame Dieselmotor  
 Frame Diesel Engine



Holland Lift International B.V.  
 Anodeweg 1  
 NL-1627 LJ Hoorn The Netherlands  
 T/F +31 (0)229-285555 / 285550  
 E service@hollandlift.com  
 W www.hollandlift.com

Dieselmotor

Projekt:  
 EB-21-001  
 Datum:  
 16.06.2015

Zeichnungsnummer:  
 =  
 Ort:  
 +

Rev.:  
 A  
 erstellt von:  
 Rothenbusch  
 Blatt:  
 2

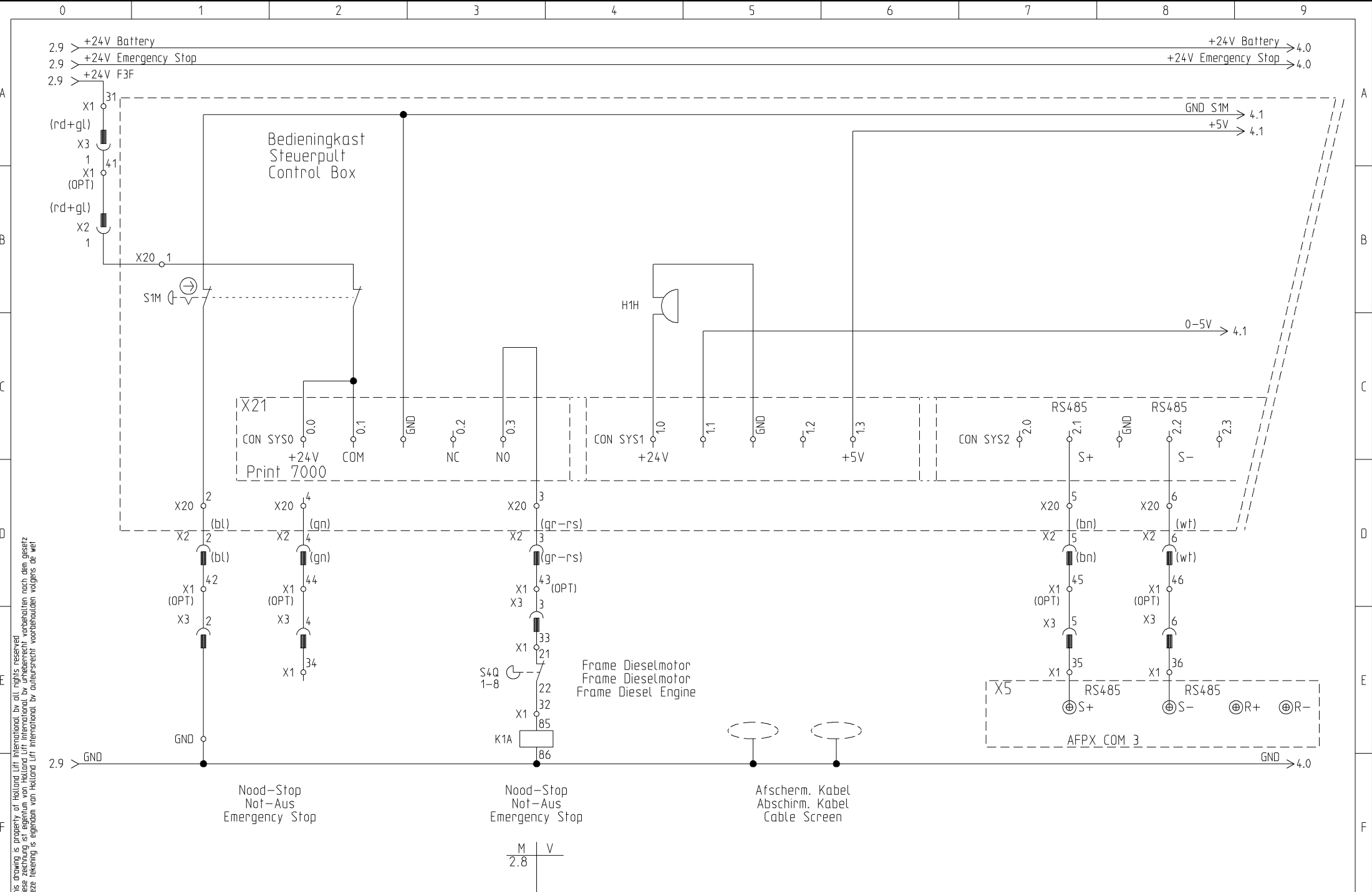

this drawing is property of Holland Lift International, by all rights reserved  
 deze tekening is eigendom van Holland Lift International, by all rights reserved  
 deze tekening is eigendom van Holland Lift International, by all rights reserved



Holland Lift International B.V.  
 Anodeweg 1  
 NL-1627 LJ Hoorn The Netherlands  
 T/F +31 (0)229-285555 / 285550  
 E service@hollandlift.com  
 W www.hollandlift.com

Bedienpult  
 Systemstecker

Projekt:	EB-21-001	Zeichnungsnummer:	Rev.:	A	erstellt von:	Rothenbusch
Datum:	16.06.2015	Anlage:	Ort:	=	Blatt:	3

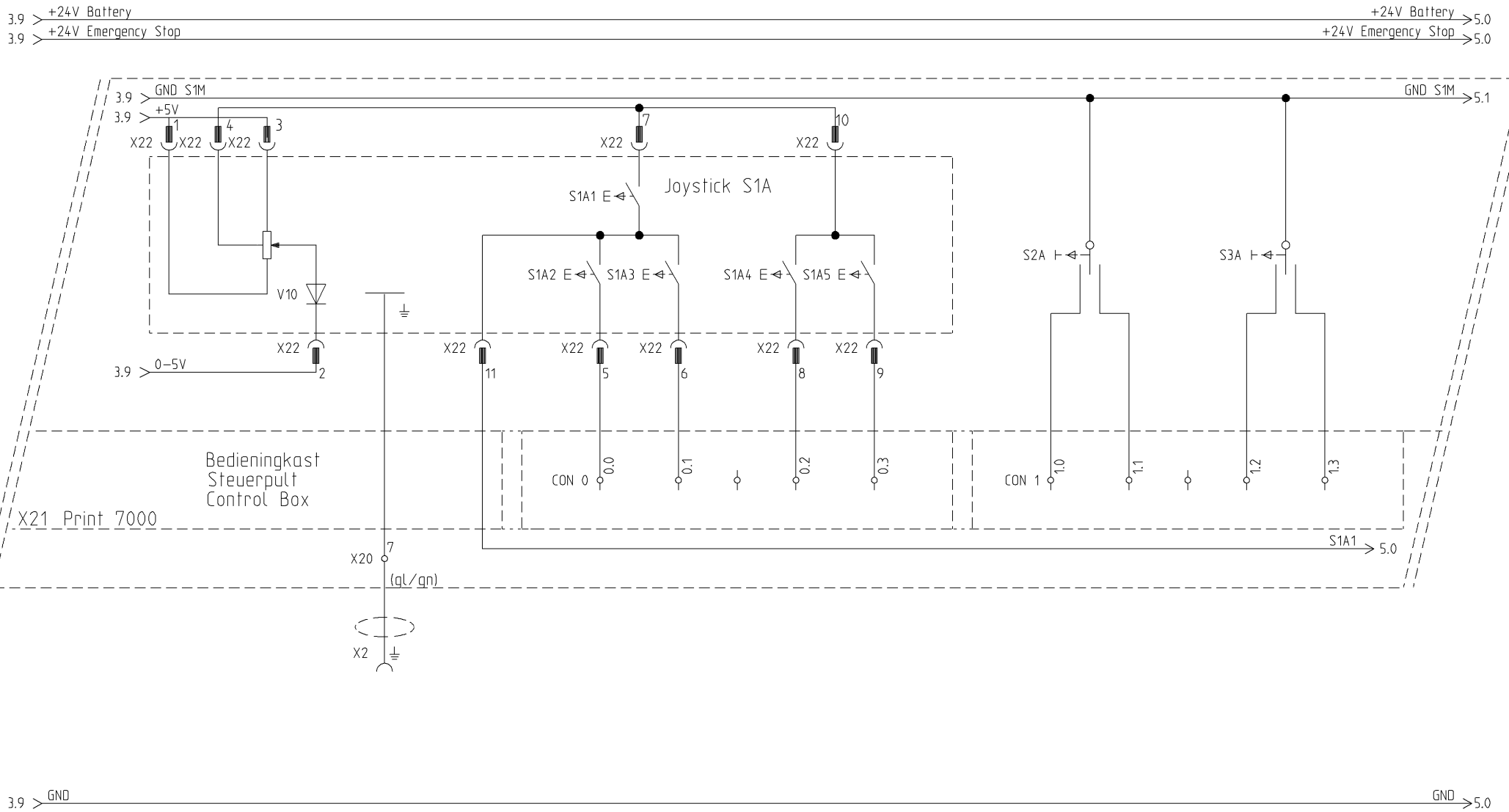

this drawing is property of Holland Lift International, by all rights reserved  
 deze tekening is eigendom van Holland Lift International, by all rights reserved  
 deze tekening is eigendom van Holland Lift International, by all rights reserved

S1A1 Dodemansknop	Vooruit-Rijden-Achteruit	Links-Sturen-Rechts	Claxon-Sign.gever	Sper/Diff	Heffen	Dalen
S1A1 Totmansknop	Vorw.-Fahren-Rueckw.	Links-Lenken-Rechts	Hupe-Signalgeber	Sperr/Diff	Heben	Senken
S1A1 Dead Man,s Button	Forward-Driving-Reverse	Left-Steering-Right	Horn-Signal	Slip/Diff	Lift Up	Lift Down

# HOLLAND LIFT

Holland Lift International B.V.  
 Anodeweg 1  
 NL-1627 LJ Hoorn The Netherlands  
 T/F +31 (0)229-285555 / 285550  
 E service@hollandlift.com  
 W www.hollandlift.com

Bedienpult  
 CON 0 - 1

Projekt:	EB-21-001	Zeichnungsnummer:	Rev.:	A	erstellt von:	Rothenbusch
Datum:	16.06.2015	Anlage:	Ort:	+	Blatt:	4

4.9 > +24V Battery  
 4.9 > +24V Emergency Stop

+24V Battery > 6.0  
 +24V Emergency Stop > 6.0

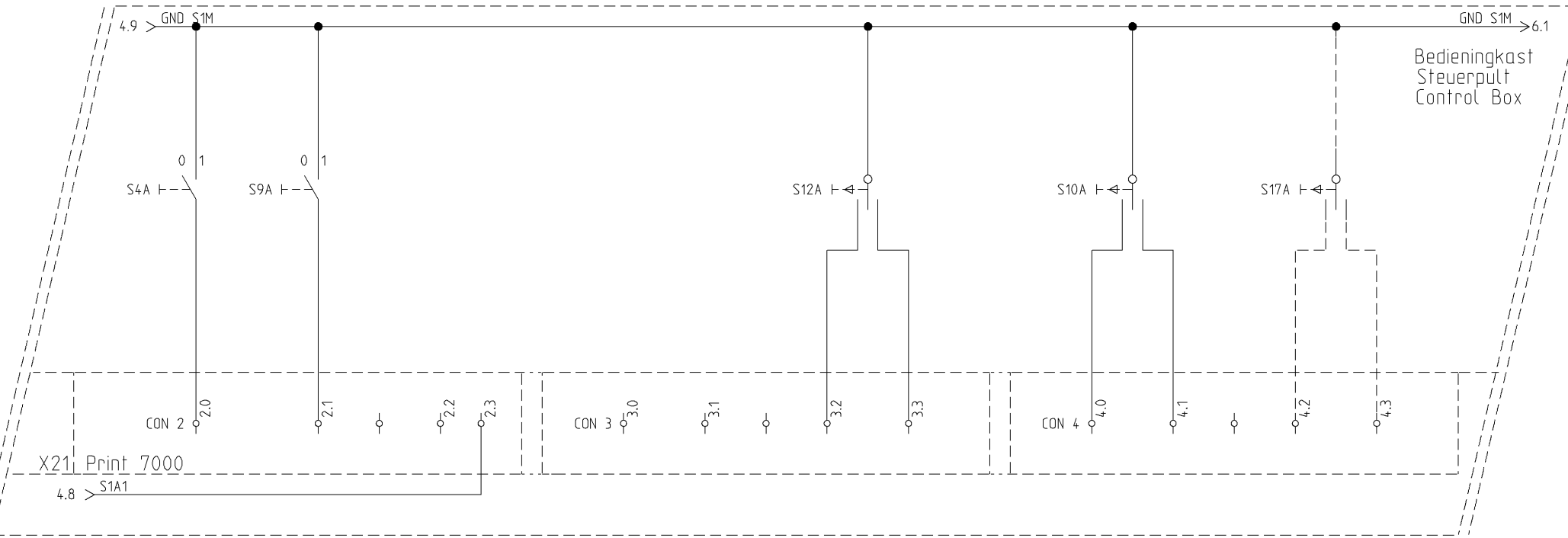

Bedieningkast  
 Steuerpult  
 Control Box

X21: Print 7000

S4A  
 0 = Langzaam Langsam Slow  
 1 = Snel Schnell Fast

S9A  
 0 = Laag Niedrig Low  
 1 = Autom. Autom. Autom.

4.9 > GND

GND > 6.0

Snelheid  
 Geschwindigkeit  
 Speed

Toerental  
 Drehzahl  
 Enging Speed

S1A1 Dodemansknop  
 S1A1 Totmansknop  
 S1A1 Dead Man's Button

4xN-Stempels-Autom. Niveleer  
 4xN-Stuetzen-Autom. Nivel.  
 4xN-Jack-Autom. Nivel

In-Plattform achter-Uit  
 Ein-Plattform hinten-Aus  
 In-Plattform rear-Out

In-Plattform voor-Uit  
 Ein-Plattform vorn-Aus  
 In-Plattform front-Out

Optie/Option

this drawing is property of Holland Lift International. By all rights reserved.  
 diese zeichnung ist eigentum von Holland Lift International. by urheberrecht vorbehalten nach dem gesetz.  
 deze tekening is eigendom van Holland Lift International. by auteursrecht voorbehouden volgens de wet.

# HOLLAND LIFT

Holland Lift International B.V.  
 Anodeweg 1  
 NL-1627 LJ Hoorn The Netherlands  
 T/F +31 (0)229-285555 / 285550  
 E service@hollandlift.com  
 W www.hollandlift.com

Bedienpult  
 CON 2 - 4

Projekt:  
 EB-21-001

Zeichnungsnummer:

Rev.: A

erstellt von:  
 Rothenbusch

Datum:  
 16.06.2015

Anlage:  
 =

Ort:  
 +

Blatt:  
 5

5.9 > +24V Battery  
 5.9 > +24V Emergency Stop

+24V Battery > 7.0  
 +24V Emergency Stop > 7.0

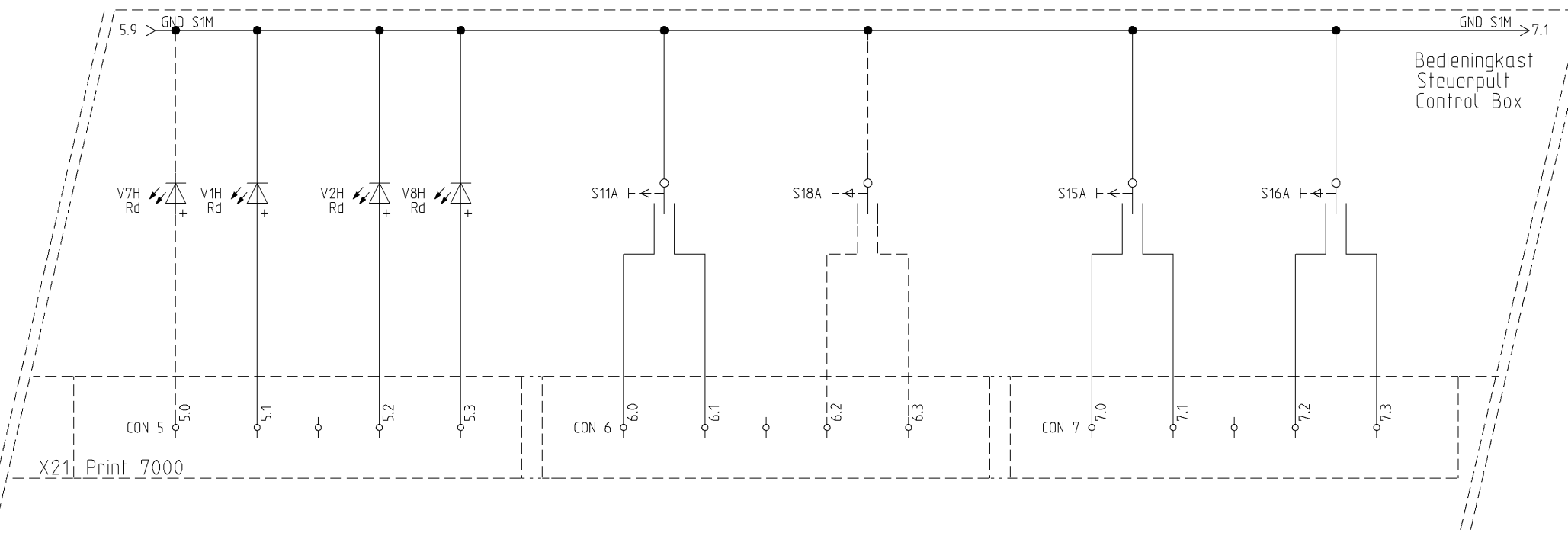

5.9 > GND

GND > 7.0

Vetpomp    Overload    Scheefstand    Tank leeg  
 Fett Pumpe    Ueberlastung    Neigung    Tank leer  
 Grease Pump    Overload    Grade/Slope    Tank empty

Start - Motor - Stop  
 Start - Motor - Halt  
 Start - Engine - Stop

Aan Generator Uit  
 An Generator Aus  
 On Generator Off

LA in    LA uit  
 LH ein    LH aus  
 LR in    LR out

RA in    RA uit  
 RH ein    RH aus  
 RR in    RR out

Optie/Option

Optie/Option

Stempels-Stuetzen-Jacks    Stempels-Stuetzen-Jacks

this drawing is property of Holland Lift International, by all rights reserved.  
 deze tekening is eigendom van Holland Lift International, by auteursrecht voorbehouden volgens de wet.  
 deze tekening is eigendom van Holland Lift International, by auteursrecht voorbehouden volgens de wet.



Holland Lift International B.V.  
 Anodeweg 1  
 NL-1627 LJ Hoorn The Netherlands  
 T/F +31 (0)229-285555 / 285550  
 E service@hollandlift.com  
 W www.hollandlift.com

Bedienpult  
 CON 5 - 7

Projekt: EB-21-001  
 Datum: 16.06.2015

Zeichnungsnummer:  
 Anlage: =

Rev.: A  
 Ort: +

erstellt von:  
 Rothenbusch  
 Blatt: 6

6.9 > +24V Battery  
 6.9 > +24V Emergency Stop

+24V Battery > 8.0  
 +24V Emergency Stop > 8.0

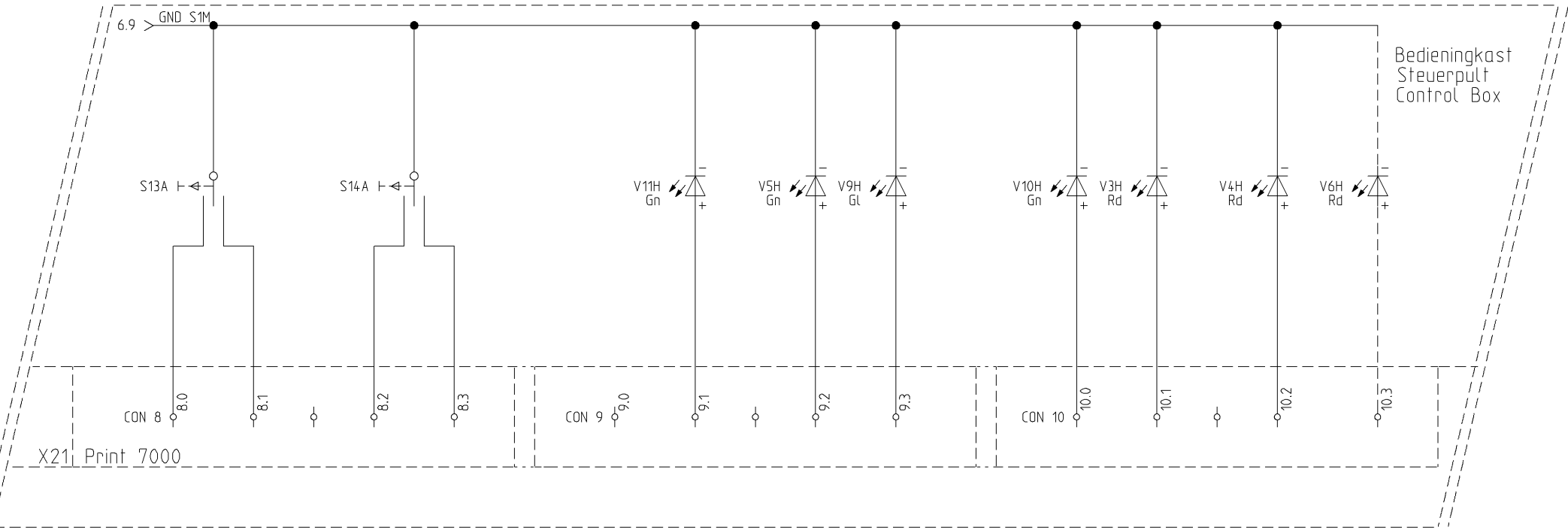

6.9 > GND

GND > 8.0

LV in    LV uit  
 LV ein    LV aus  
 LF in    LF out

RV in    RV uit  
 RV ein    RV aus  
 RF in    RF out

Stempels in    Stempels uit  
 Stuetzen ein    Stuetzen aus  
 Jacks in    Jacks out

Autom. Niv.  
 Autom. Niv.  
 Autom. Niv.

In Bedrijf    Storing  
 In Betrieb    Stoerung  
 Run    Failure

Pendelas Hor.  
 Pendel A. Hor.

Plat. voor-in  
 Platt. vorn-ein  
 Plat. front-in

Stempels-Stuetzen-Jacks    Stempels-Stuetzen-Jacks

Diesel Motor

Optie/Option

this drawing is property of Holland Lift International, by all rights reserved  
 deze tekening is eigendom van Holland Lift International, by all rights reserved  
 deze tekening is eigendom van Holland Lift International, by auteursrecht voorbehouden volgens de wet

# HOLLAND LIFT

Holland Lift International B.V.  
 Anodeweg 1  
 NL-1627 LJ Hoorn The Netherlands  
 T/F +31 (0)229-285555 / 285550  
 E service@hollandlift.com  
 W www.hollandlift.com

Bedienpult  
 CON 8 - 10

Projekt:  
 EB-21-001

Zeichnungsnummer:

Rev.: A

erstellt von:  
 Rothenbusch

Datum:  
 16.06.2015

Anlage:  
 =

Ort:  
 +

Blatt:  
 7

7.9 > +24V Battery  
7.9 > +24V Emergency Stop

+24V Battery > 9.0  
+24V Emergency Stop > 9.0

Bedieningkast  
Steuerpult  
Control Box

X21, Print 7000

CON 11 ⌀11.0   ⌀11.1   ⌀   ⌀11.2   ⌀11.3

7.9 > GND

GND > 9.0

this drawing is property of Holland Lift International, by all rights reserved  
deze tekening is eigendom van Holland Lift International, by auteursrecht voorbehouden volgens de wet

# HOLLAND LIFT

Holland Lift International B.V.  
Anodeweg 1  
NL-1627 LJ Hoorn The Netherlands  
T/F +31 (0)229-285555 / 285550  
E service@hollandlift.com  
W www.hollandlift.com

Bedienpult  
CON 11

Projekt:	EB-21-001	Zeichnungsnummer:	Rev.:	A	erstellt von:	Rothenbusch	
Datum:	16.06.2015	Antage:	=	Ort:	+	Blatt:	8



this drawing is property of Holland Lift International, by all rights reserved.  
 deze tekening is eigendom van Holland Lift International, by all rights reserved.  
 deze tekening is eigendom van Holland Lift International, by all rights reserved.

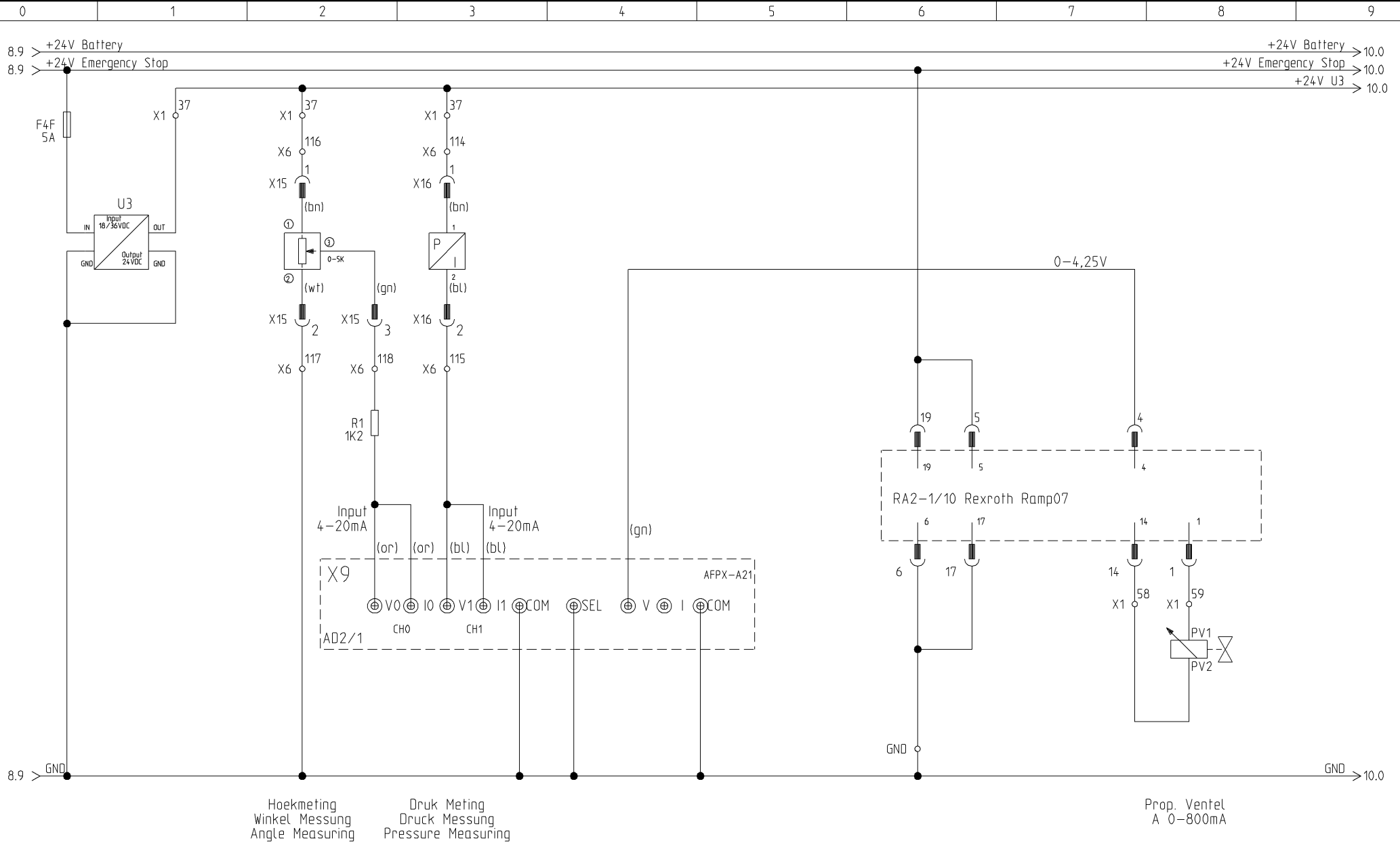

Hoekmeting Winkel Messung Angle Measuring  
 Druk Meting Druck Messung Pressure Measuring

Prop. Ventel A 0-800mA



Holland Lift International B.V.  
 Anodeweg 1  
 NL-1627 LJ Hoorn The Netherlands  
 T/F +31 (0)229-285555 / 285550  
 E service@hollandlift.com  
 W www.hollandlift.com

Analogeingänge  
 Ramp 07

Projekt:	EB-21-001	Zeichnungsnummer:	Rev.:	A	erstellt von:	Rothenbusch
Datum:	16.06.2015	Anlage:	Ort:	=	Blatt:	9

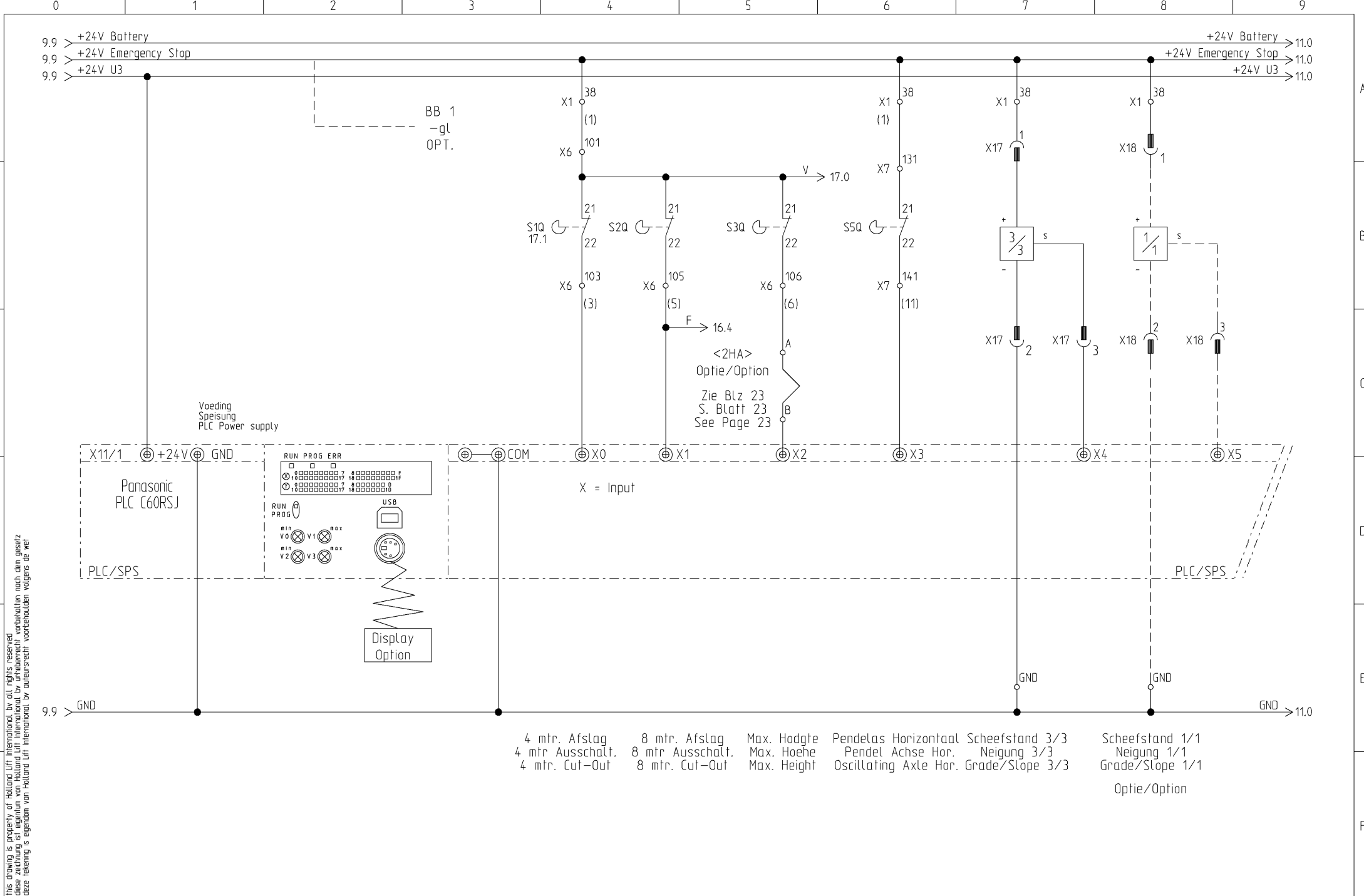

this drawing is property of Holland Lift International, by all rights reserved  
 diese zeichnung ist eigentum von Holland Lift International, by urheberrecht vorbehalten nach dem gesetz  
 deze tekening is eigendom van Holland Lift International, by auteursrecht voorbehouden volgens de wet

this drawing is property of Holland Lift International, by all rights reserved  
 deze tekening is eigendom van Holland Lift International, by all rights reserved  
 deze tekening is eigendom van Holland Lift International, by auteursrecht voorbehouden volgens de wet

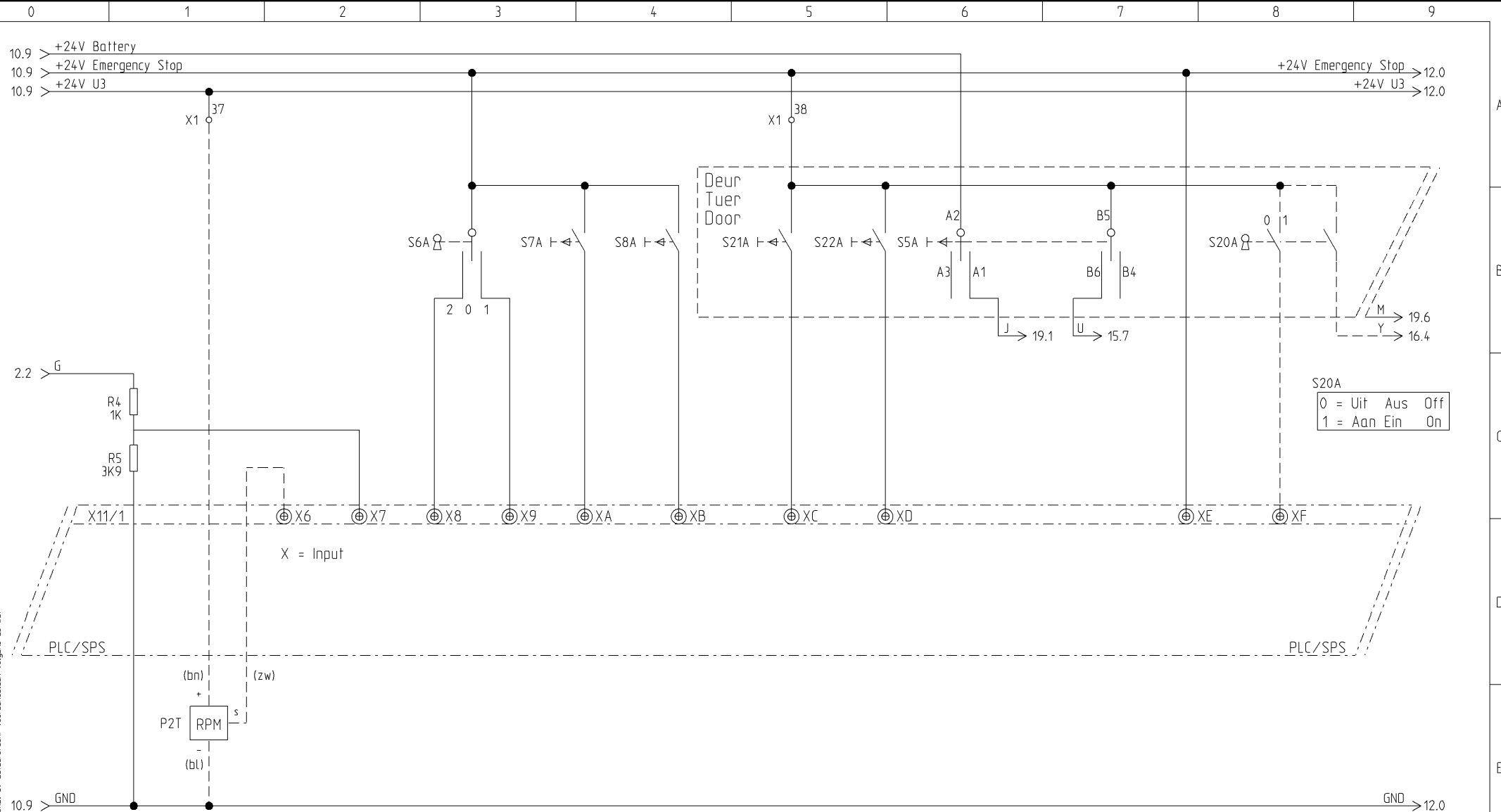

RPM Teller Gen.  
RPM Zaehler Gen.  
RPM Meter Gen.

W+ Dieselmotor

Progr. Uit    Aan    Store    Save  
 Progr. Aus    An    Store    Save  
 Progr. Off    On    Store    Save

Start - Motor - Stop  
 Start - Motor - Halt  
 Start - Engine - Stop

Heffen - Dalem  
 Heben - Senken  
 Lift Up - Lift Down

Overbr. Daalbev  
 Ueberbr. Senkschutz  
 Bridge Lift down protec.

Ri. max. Hoogte  
 Fa. max. Hoehe  
 Dr. max. Height

Optie/Option

— Overlast-Ueberlastung-Overload —

Optie/Option



Holland Lift International B.V.  
 Anodeweg 1  
 NL-1627 LJ Hoorn The Netherlands  
 T/F +31 (0)229-285555 / 285550  
 E service@hollandlift.com  
 W www.hollandlift.com

SPS Input  
 X6 - XF

Projekt: EB-21-001  
 Datum: 16.06.2015

Zeichnungsnummer:  
 Anlage: =

Rev.: A  
 Ort: +

erstellt von:  
 Rothenbusch  
 Blatt: 11

this drawing is property of Holland Lift International, by all rights reserved  
 deze tekening is eigendom van Holland Lift International, by all rights reserved  
 deze tekening is eigendom van Holland Lift International, by all rights reserved

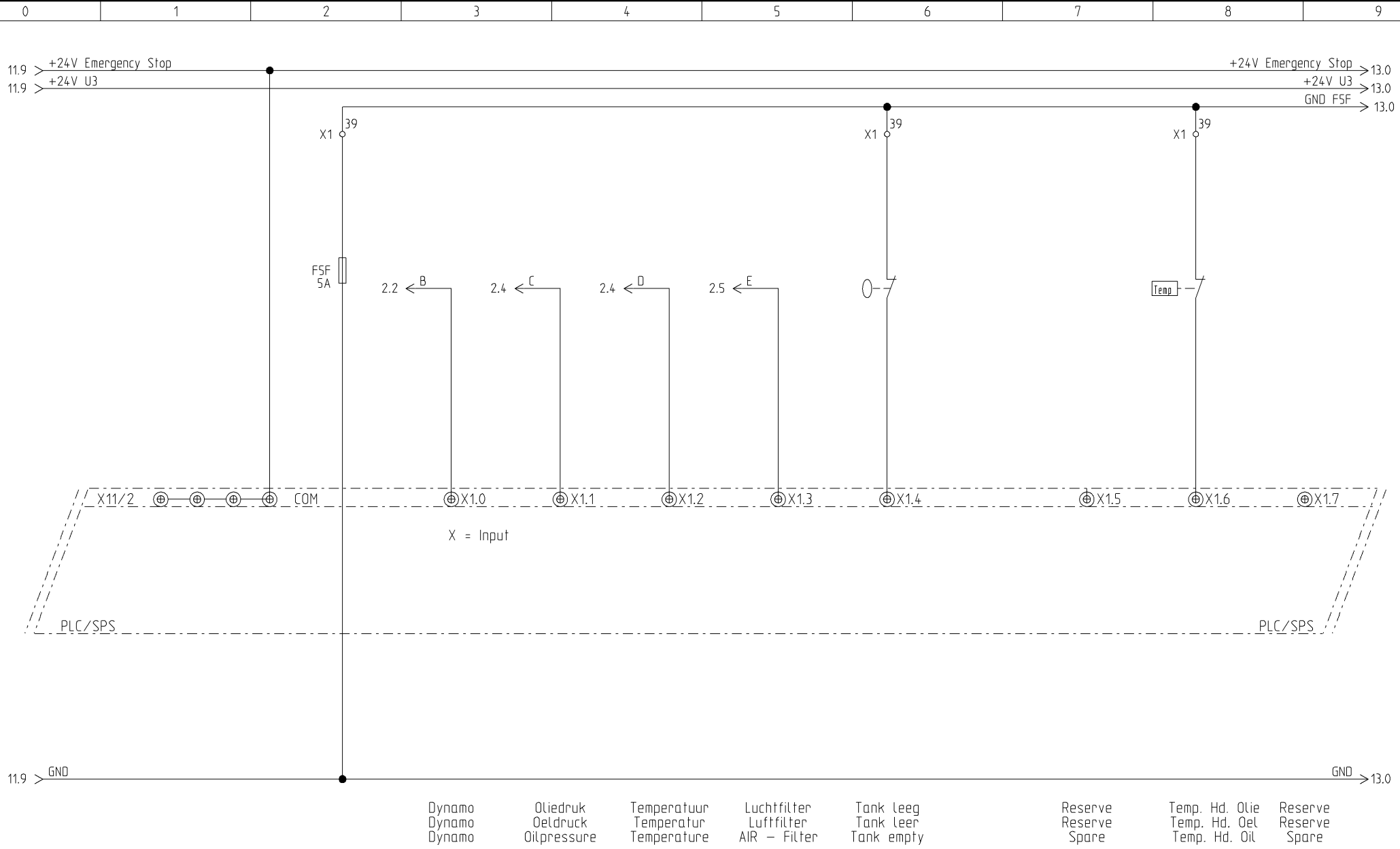

- Dynamo  
Dynamo  
Dynamo
- Oliedruk  
Oeldruk  
Oilpressure
- Temperatuur  
Temperatur  
Temperature
- Luchtfilter  
Luffilter  
AIR - Filter
- Tank leeg  
Tank leer  
Tank empty
- Reserve  
Reserve  
Spare
- Temp. Hd. Olie  
Temp. Hd. Oel  
Temp. Hd. Oil
- Reserve  
Reserve  
Spare



Holland Lift International B.V.  
 Anodeweg 1  
 NL-1627 LJ Hoorn The Netherlands  
 T/F +31 (0)229-285555 / 285550  
 E service@hollandlift.com  
 W www.hollandlift.com

SPS Input  
X1.0 - X1.7

Projekt:	EB-21-001	Zeichnungsnummer:	Rev.:	A	erstellt von:	Rothenbusch
Datum:	16.06.2015	Anlage:	=	Ort:	+	Blatt:
						12

this drawing is property of Holland Lift International, by all rights reserved  
 deze tekening is eigendom van Holland Lift International, by all rights reserved  
 deze tekening is eigendom van Holland Lift International, by all rights reserved

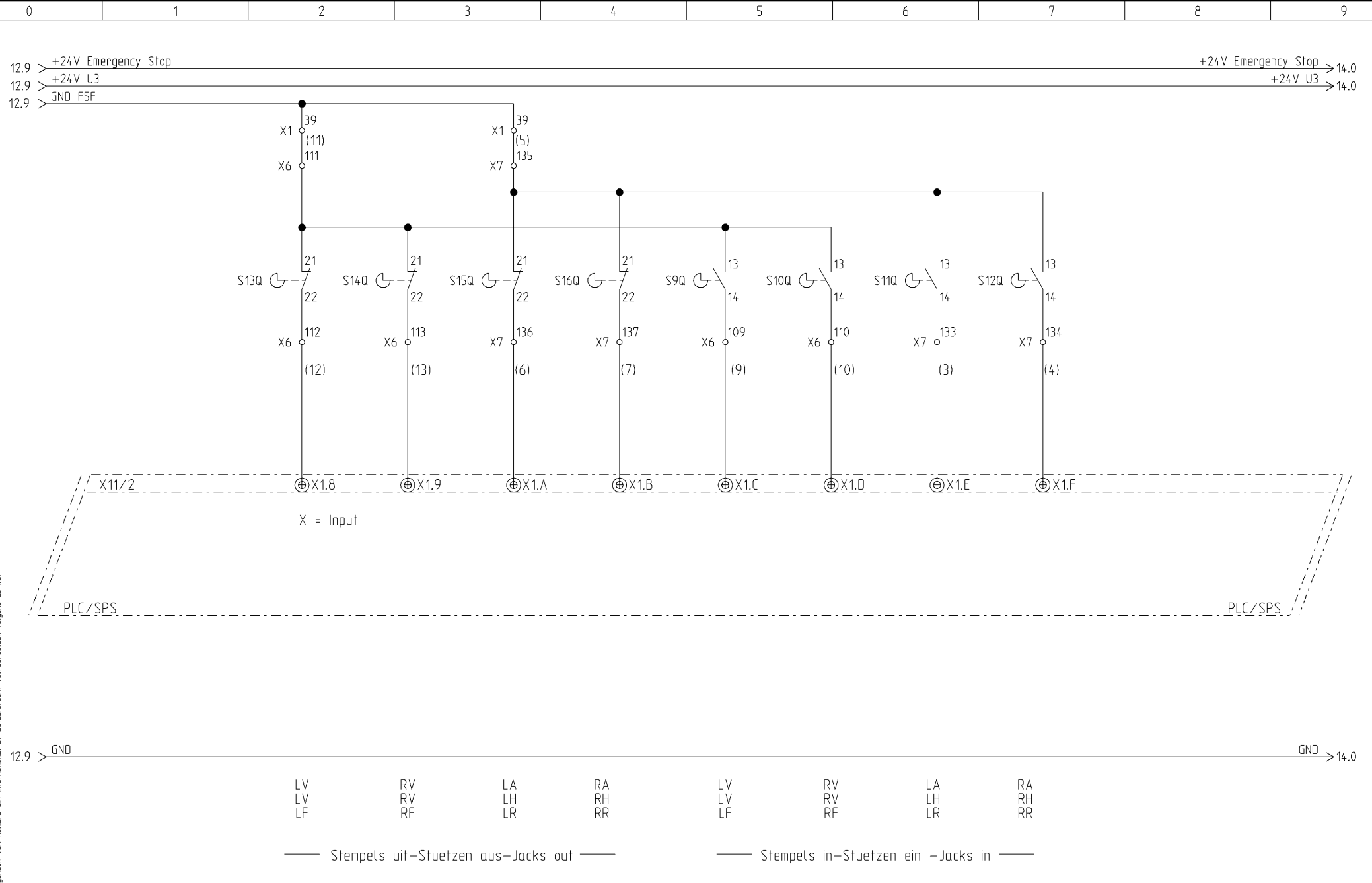

Holland Lift International B.V.  
 Anodeweg 1  
 NL-1627 LJ Hoorn The Netherlands  
 T/F +31 (0)229-285555 / 285550  
 E service@hollandlift.com  
 W www.hollandlift.com

SPS Input  
 X1.8 - X1.F

Projekt:	EB-21-001	Zeichnungsnummer:	Rev.:	A	erstellt von:	Rothenbusch
Datum:	16.06.2015	Anlage:	Ort:	=	Blatt:	13

this drawing is property of Holland Lift International, by all rights reserved  
 deze tekening is eigendom van Holland Lift International, by all rights reserved  
 deze tekening is eigendom van Holland Lift International, by auteursrecht voorbehouden volgens de wet

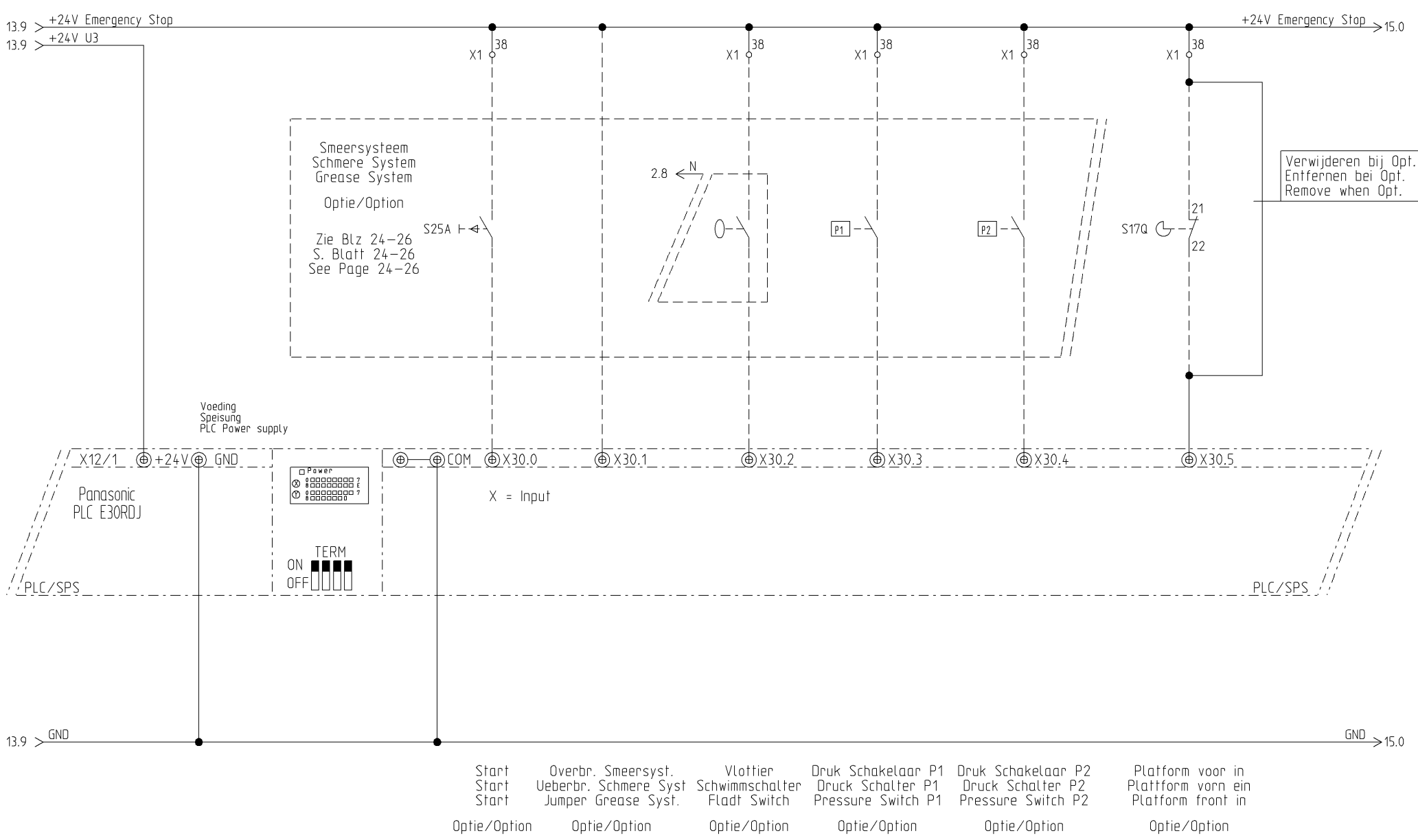

this drawing is property of Holland Lift International, by all rights reserved.  
 deze tekening is eigendom van Holland Lift International, by all rights reserved.  
 deze tekening is eigendom van Holland Lift International, by auteursrecht voorbehouden volgens de wet

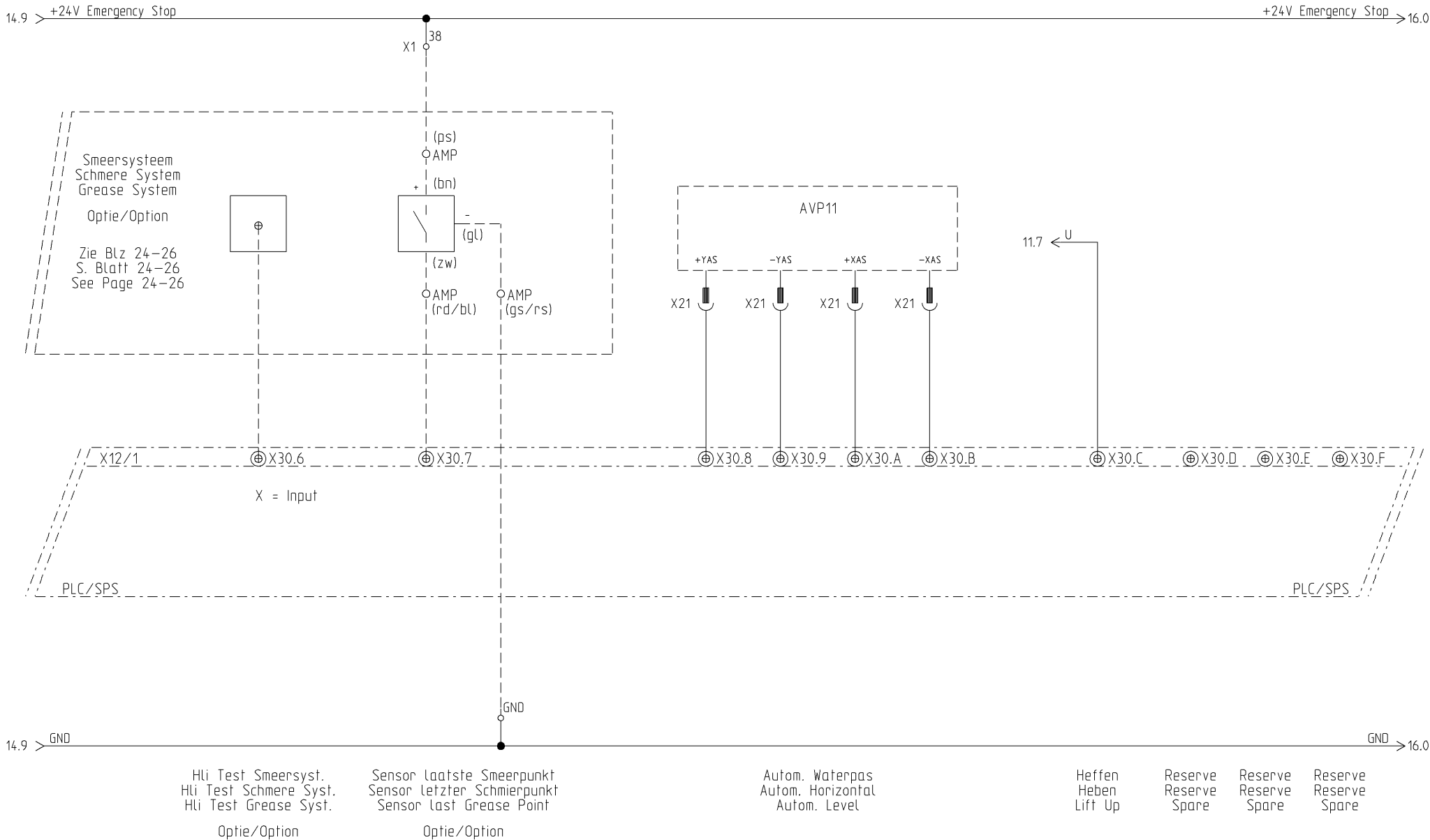

Hli Test Smeersyst.  
Hli Test Schmere Syst.  
Hli Test Grease Syst.  
Optie/Option

Sensor laatste Smeerpunt  
Sensor letzter Schmierpunkt  
Sensor last Grease Point  
Optie/Option

Autom. Waterpas  
Autom. Horizontal  
Autom. Level

Heffen  
Lift Up

Reserve  
Reserve  
Spare

Reserve  
Reserve  
Spare

Reserve  
Reserve  
Spare

this drawing is property of Holland Lift International, by all rights reserved  
 deze tekening is eigendom van Holland Lift International, by all rights reserved  
 deze tekening is eigendom van Holland Lift International, by all rights reserved

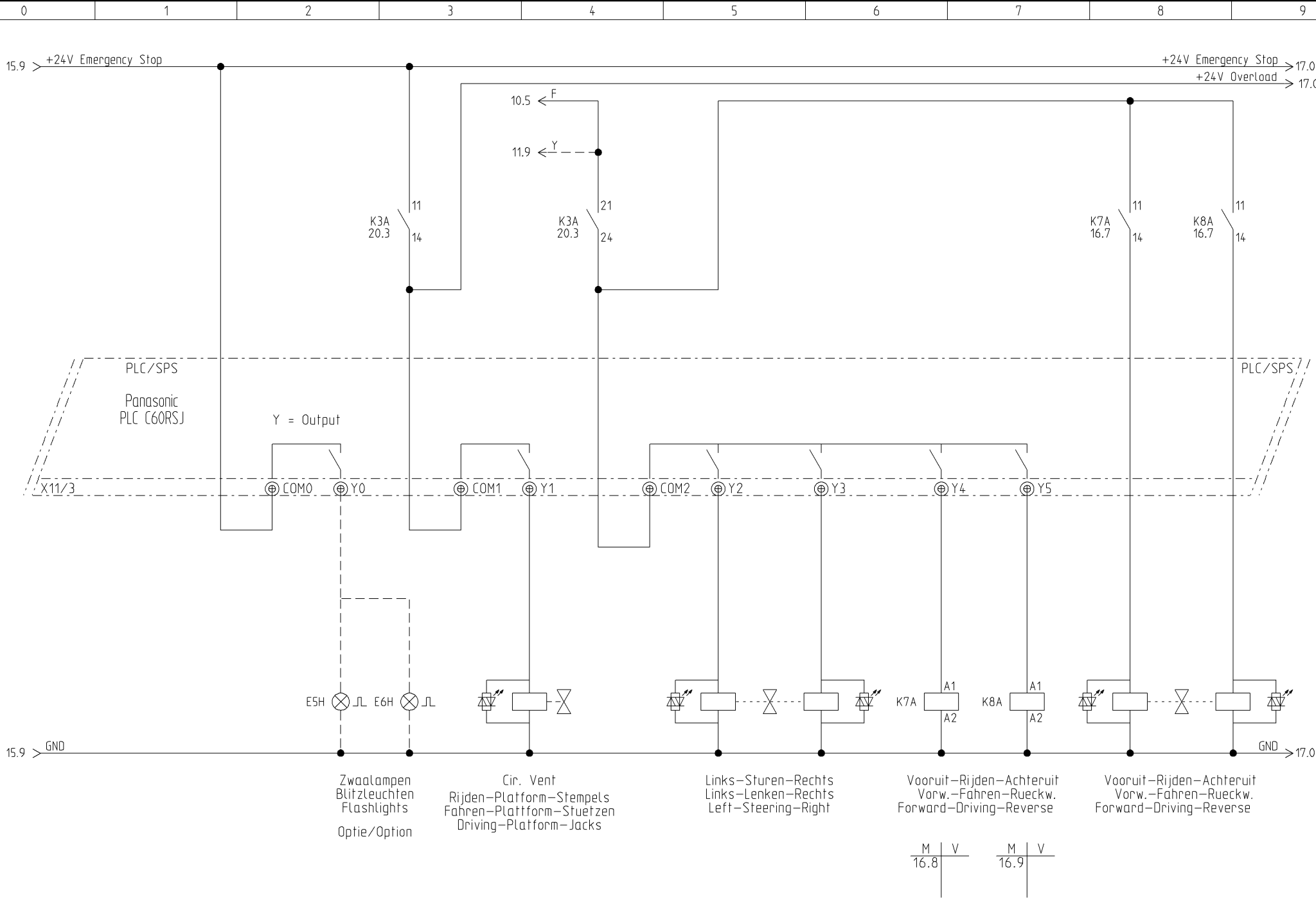

Holland Lift International B.V.  
 Anodeweg 1  
 NL-1627 LJ Hoorn The Netherlands  
 T/F +31 (0)229-285555 / 285550  
 E service@hollandlift.com  
 W www.hollandlift.com

SPS Output  
 Y0 - Y5

Projekt: EB-21-001  
 Datum: 16.06.2015

Zeichnungsnummer:  
 Anlage: =

Rev.: A  
 Ort: +

erstellt von:  
 Rothenbusch  
 Blatt:  
 16



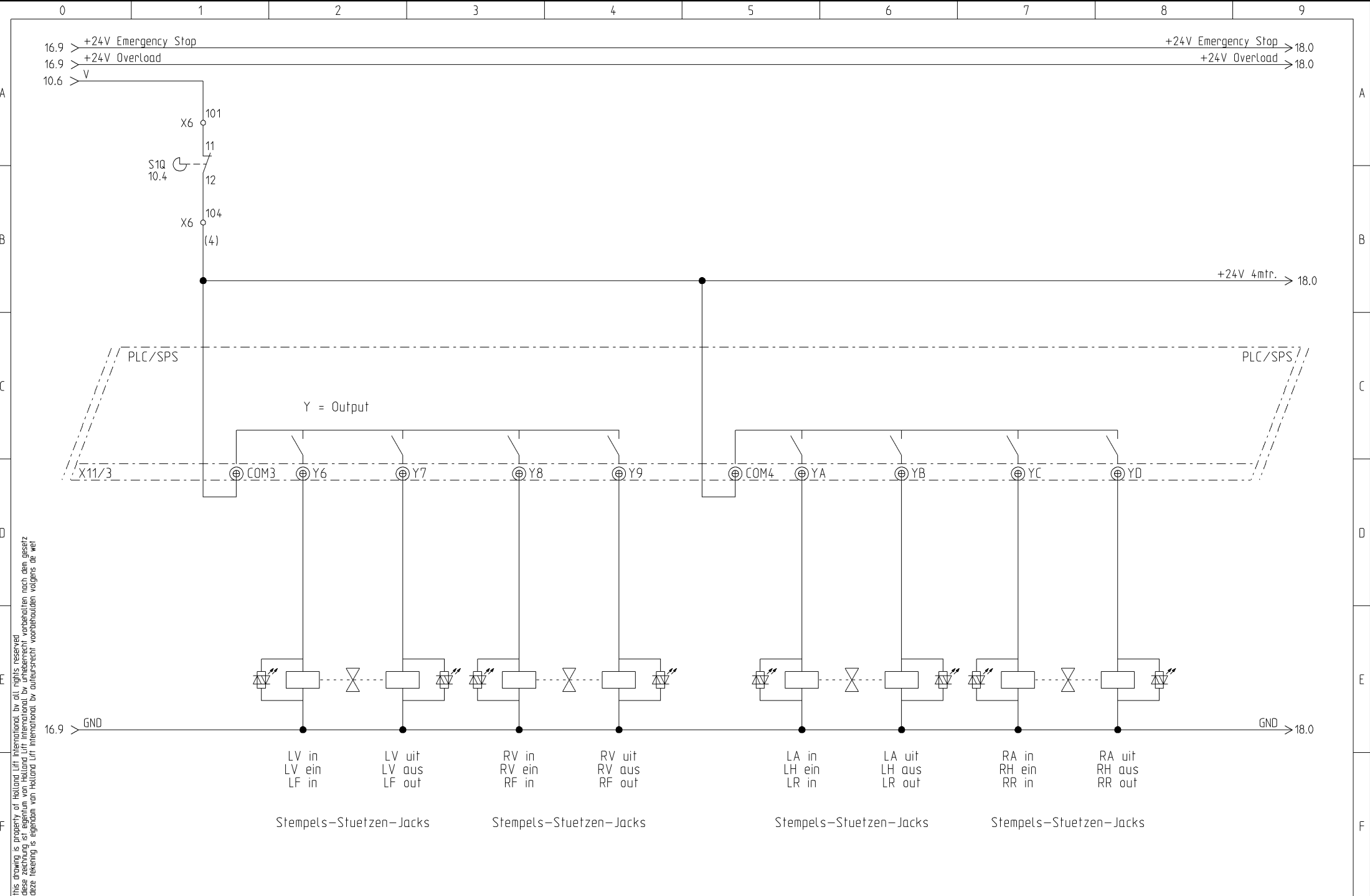

this drawing is property of Holland Lift International, by all rights reserved.  
 deze tekening is eigendom van Holland Lift International, by all rights reserved.  
 deze tekening is eigendom van Holland Lift International, by all rights reserved.

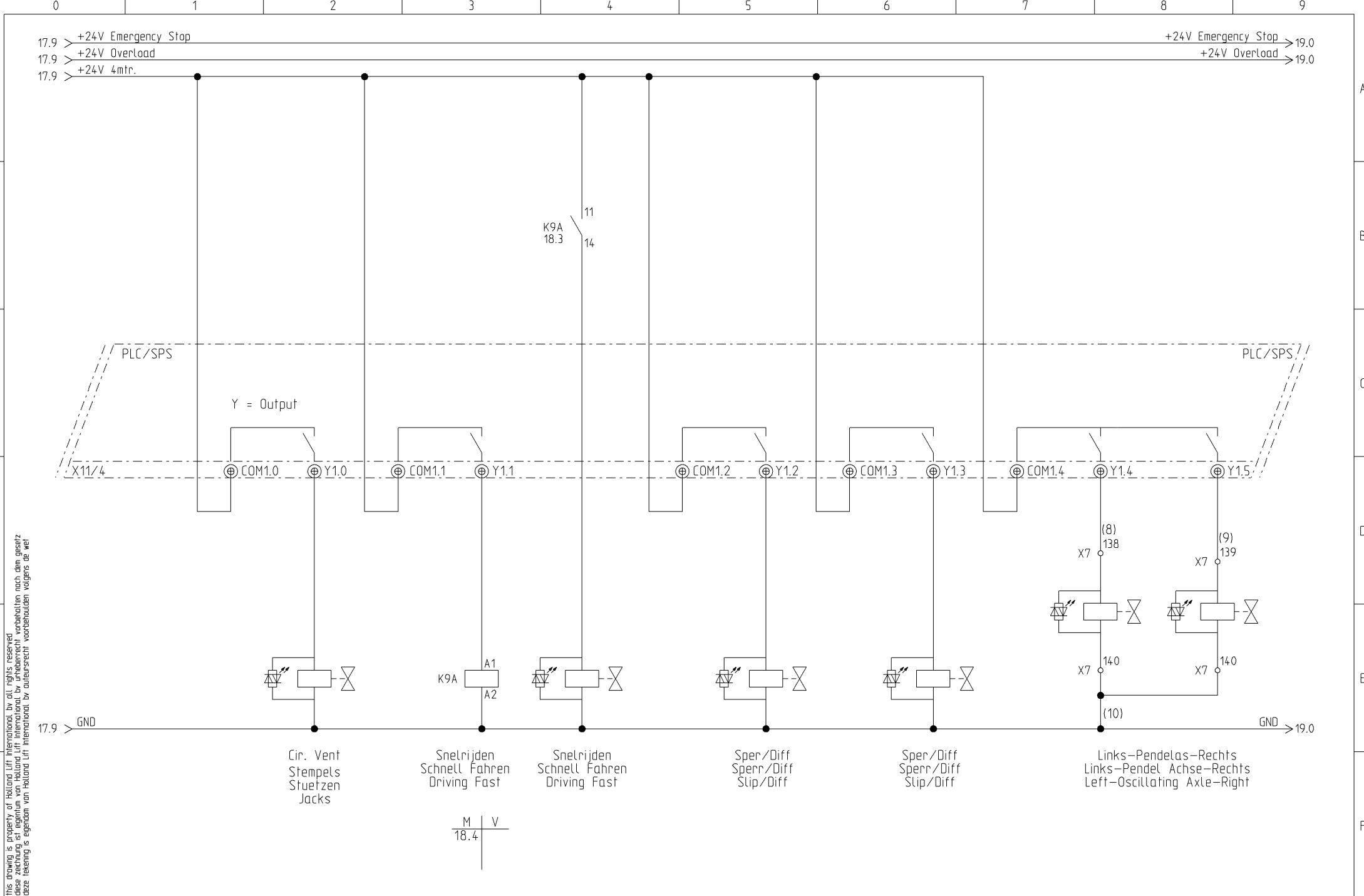

this drawing is property of Holland Lift International, by all rights reserved.  
 deze tekening is eigendom van Holland Lift International, by auteursrecht voorbehouden volgens de wet.  
 deze tekening is eigendom van Holland Lift International, by auteursrecht voorbehouden volgens de wet.



Holland Lift International B.V.  
 Anodeweg 1  
 NL-1627 LJ Hoorn The Netherlands  
 T/F +31 (0)229-285555 / 285550  
 E service@hollandlift.com  
 W www.hollandlift.com

SPS Output  
 Y1.0 - Y1.5

Projekt: EB-21-001  
 Datum: 16.06.2015

Zeichnungsnummer:  
 Anlage: =

Rev.: A  
 Ort: +

erstellt von:  
 Rothenbusch  
 Blatt: 18

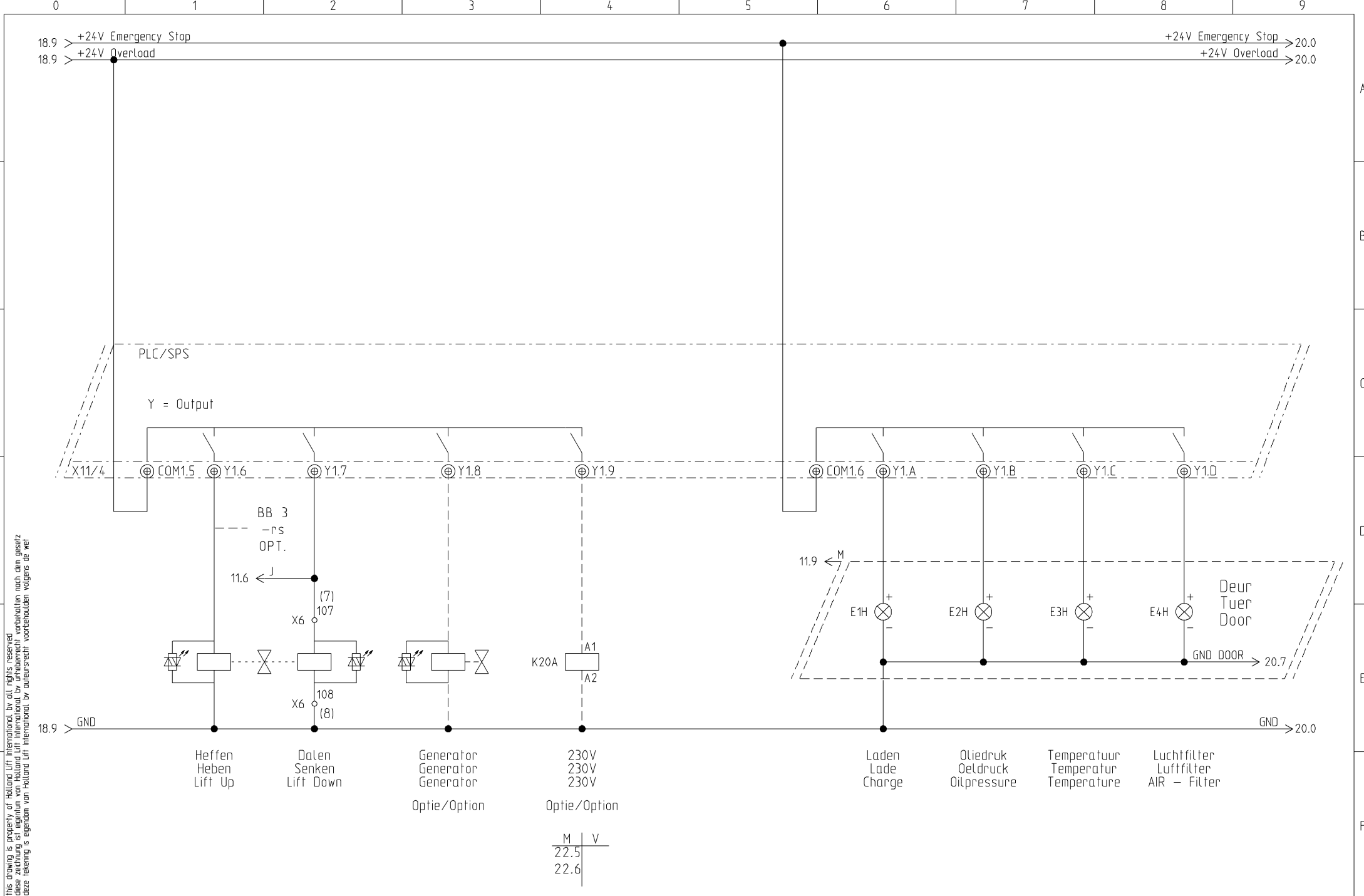

this drawing is property of Holland Lift International, by all rights reserved  
 deze tekening is eigendom van Holland Lift International, by all rights reserved  
 deze tekening is eigendom van Holland Lift International, by all rights reserved



Holland Lift International B.V.  
 Anodeweg 1  
 NL-1627 LJ Hoorn The Netherlands  
 T/F +31 (0)229-285555 / 285550  
 E service@hollandlift.com  
 W www.hollandlift.com

SPS Output  
 Y1.6 - Y1.10

Projekt: EB-21-001  
 Datum: 16.06.2015

Zeichnungsnummer:  
 Anlage: =

Rev.: A  
 Ort: +

erstellt von:  
 Rothenbusch  
 Blatt:  
 19

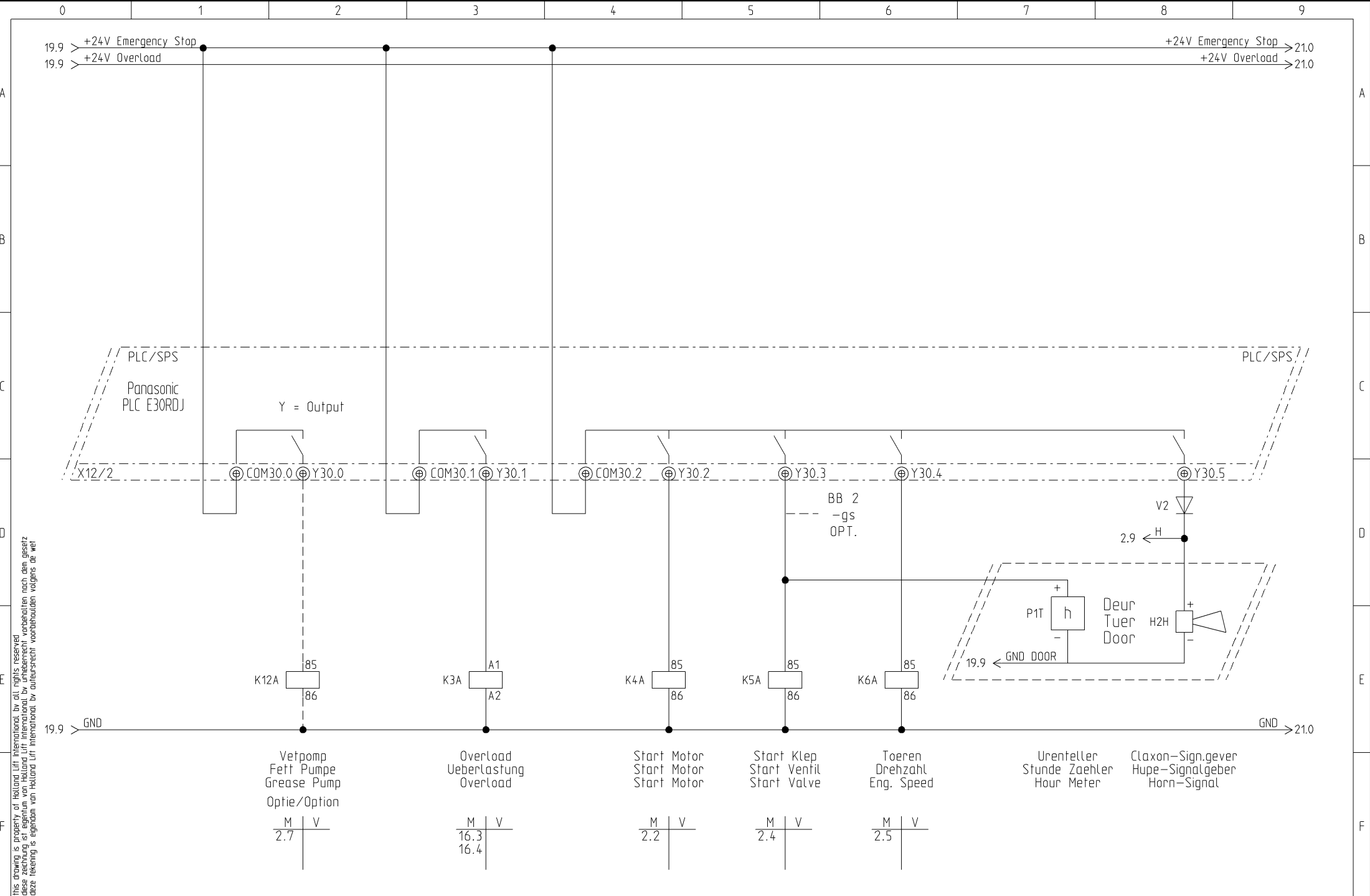

this drawing is property of Holland Lift International, by all rights reserved  
 deze tekening is eigendom van Holland Lift International, by all rights reserved  
 deze tekening is eigendom van Holland Lift International, by all rights reserved

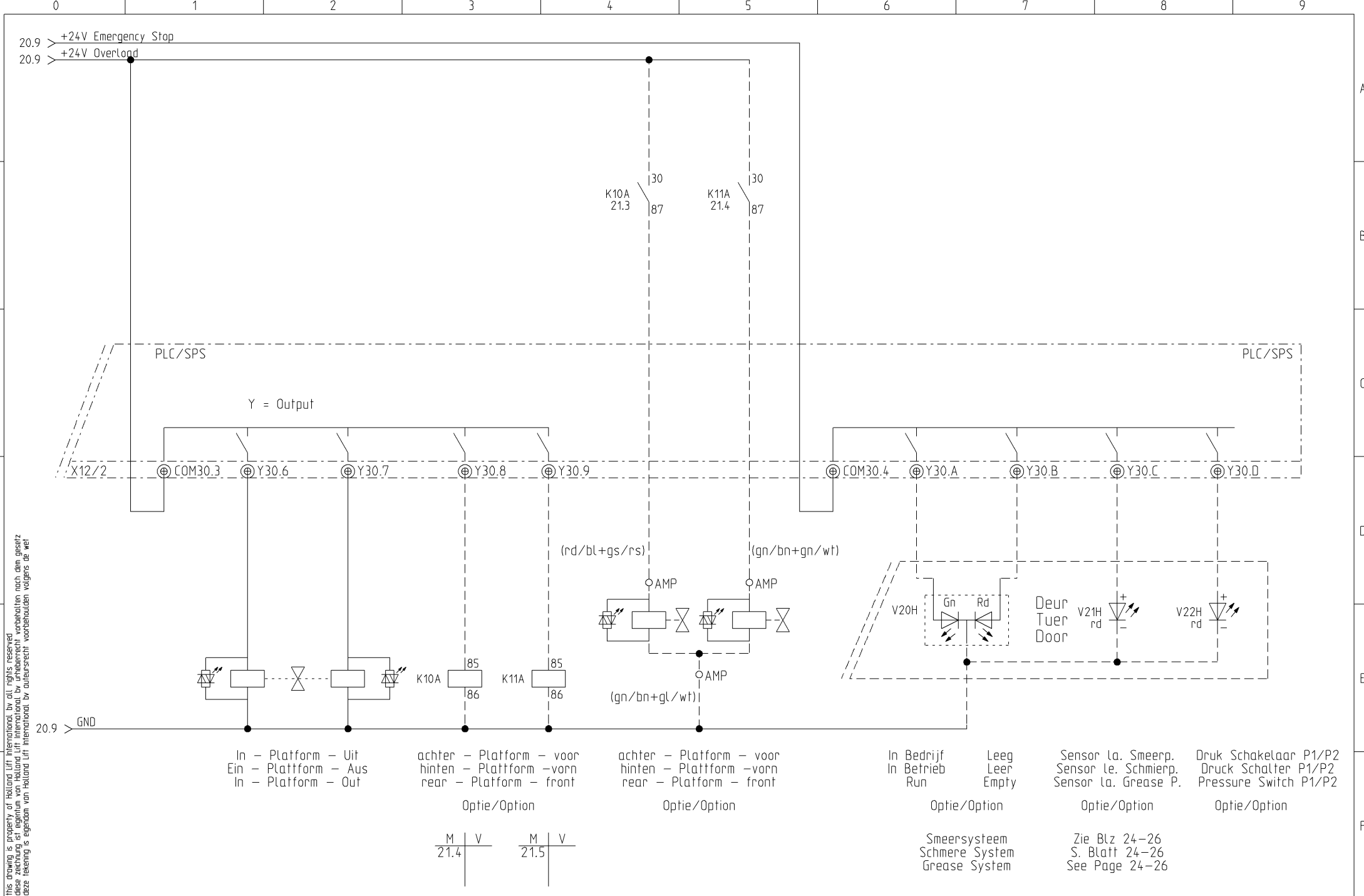

this drawing is property of Holland Lift International, by all rights reserved  
 deze tekening is eigendom van Holland Lift International, by all rights reserved  
 deze tekening is eigendom van Holland Lift International, by all rights reserved



Holland Lift International B.V.  
 Anodeweg 1  
 NL-1627 LJ Hoorn The Netherlands  
 T/F +31 (0)229-285555 / 285550  
 E service@hollandlift.com  
 W www.hollandlift.com

SPS Output  
 Y30.6 - Y30.D

Projekt: EB-21-001  
 Datum: 16.06.2015

Zeichnungsnummer:  
 Anlage:  
 Ort: =

Rev.: A  
 +

erstellt von:  
 Rothenbusch  
 Blatt: 21

OPTIES  
OPTIONEN  
OPTIONS

230V AANSLUITING PLATFORM  
230V ANSCHLUSS PLATTFORM  
230V SUPPLY PLATFORM

<230VPLF>

230V-50Hz/115V-50Hz

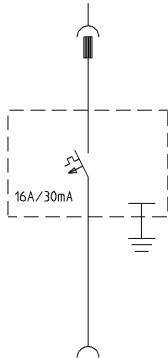

AARDLEKATOMAAT  
FI SCHALTER  
EARTH DETECTOR

230V AANSLUITING PLATFORM  
230V ANSCHLUSS PLATTFORM  
230V SUPPLY PLATFORM

<230V-GEN>

230V-50Hz/115V-50Hz

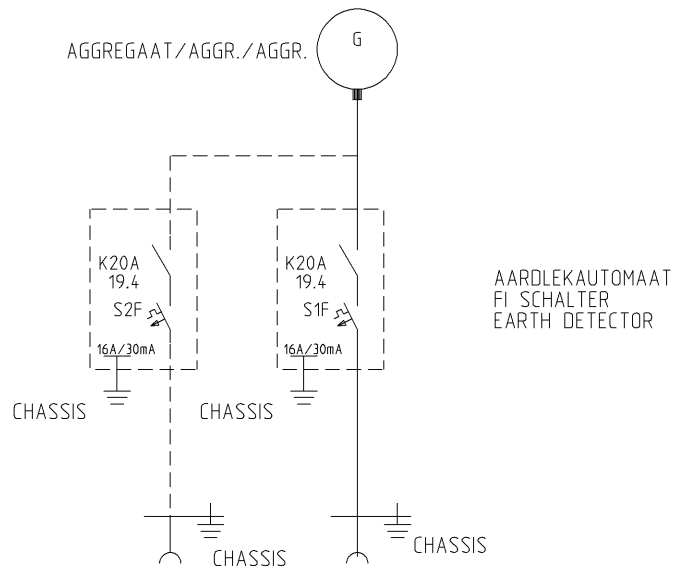

AGGREGAAT / AGGR. / AGGR.

AARDLEKATOMAAT  
FI SCHALTER  
EARTH DETECTOR

this drawing is property of Holland Lift International, by all rights reserved  
 deze tekening is eigendom van Holland Lift International, by auteursrecht voorbehouden volgens de wet  
 deze tekening is eigendom van Holland Lift International, by auteursrecht voorbehouden volgens de wet

OPTIES  
OPTIONEN  
OPTIONS

2e HOOGTE AFLSAG  
2e HOEHE AUSSCHALTUNG  
2nd HEIGHT CUT-OUT

<2HA>

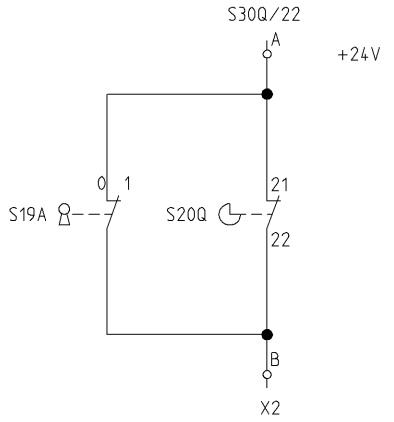

Zie Blz 10  
S. Blatt 10  
See Page 10

S19A

0 = Max. Hoogte/Max. Hoehe/Max. Height  
1 = 2e HOOGTE AFL./2e H. AUSS./2nd H. CUT-OUT

OPTIE BLACK-BOX MINI DAT					(HLI)
OPTION BLACK-BOX MINI DAT					
OPTION BLACK-BOX MINI DAT					
BB-wt	+24V DC	+24V DC	+24V DC	+24V DC	
BB-bn	GND	GND	GND	GND	
BB-gl	CH1	IN BEDRIJF	IN BETRIEB	RUNNING	
BB-gs	CH2	MOTOR	MOTOR	MOTOR	
BB-rs	CH3	HEFFEN	HEBEN	LIFT UP	
BB-bl	CH4	RIJDEN	FAHREN	DRIVING	
BB-rd	CH5	RESERVE	RESERVE	SPARE	

this drawing is property of Holland Lift International, by all rights reserved  
 diese zeichnung ist eigentum von Holland Lift International, by urheberrecht vorbehalten nach dem gesetz  
 deze tekening is eigendom van Holland Lift International, by auteursrecht voorbehouden volgens de wet



Holland Lift International B.V.  
Anodeweg 1  
NL-1627 LJ Hoorn The Netherlands  
T/F +31 (0)229-285555 / 285550  
E service@hollandlift.com  
W www.hollandlift.com

Optionen

Projekt:	EB-21-001	Zeichnungsnummer:	Rev.:	A	erstellt von:	Rothenbusch	
Datum:	16.06.2015	Antage:	=	Ort:	+	Blatt:	23

OPTIES  
OPTIONEN  
OPTIONS

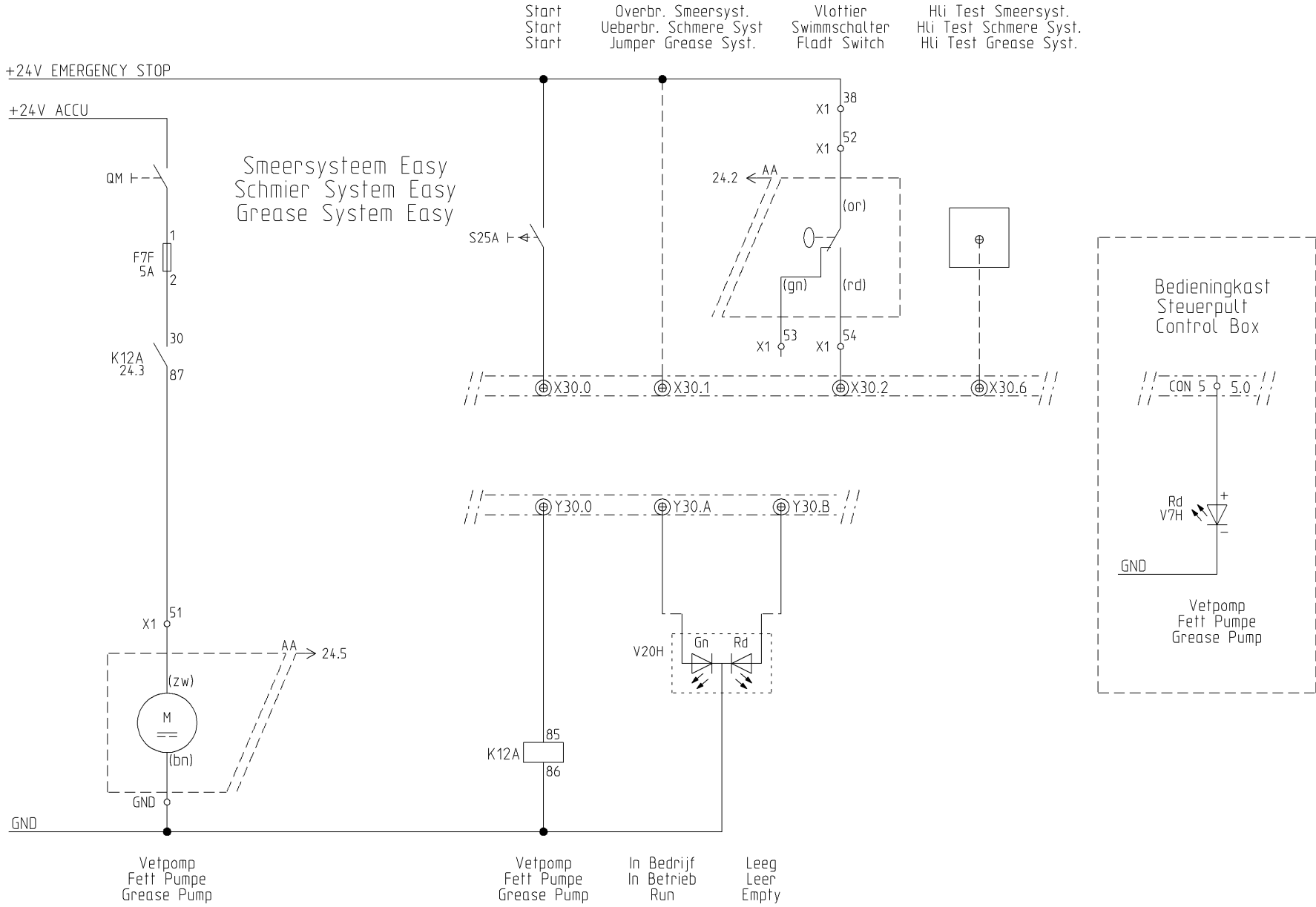

this drawing is property of Holland Lift International, by all rights reserved  
 deze tekening is eigendom van Holland Lift International, by alle rechten voorbehouden  
 deze tekening is eigendom van Holland Lift International, by auteursrecht voorbehouden volgens de wet



Holland Lift International B.V.  
 Anodeweg 1  
 NL-1627 LJ Hoorn The Netherlands  
 T/F +31 (0)229-285555 / 285550  
 E service@hollandlift.com  
 W www.hollandlift.com

Optionen

Projekt:	EB-21-001	Zeichnungsnummer:	Rev.:	A	erstellt von:	Rothenbusch
Datum:	16.06.2015	Anlage:	Ort:	+	Blatt:	24



# OPTIES OPTIONEN OPTIONS

Start	Overbr. Smeersyst.	Vlottier	Onderwagen P1	Schaar P2	Hli Test Smeersyst.	Sensor laatste Smeerpunt
Start	Ueberbr. Schmere Syst	Swimmschalter	Chassis P1	Schere P2	Hli Test Schmere Syst.	Sensor letzter Schmierpunkt
Start	Jumper Grease Syst.	Fladt Switch	Chassis P1	Scissor P2	Hli Test Grease Syst.	Sensor Last Grease Point

+24V EMERGENCY STOP

+24V ACCU

Smeersysteem Beka  
Schmier System Beka  
Grease System Beka

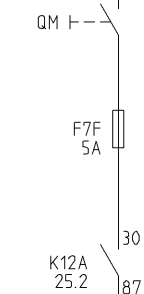

S25A

25.1 ← AB

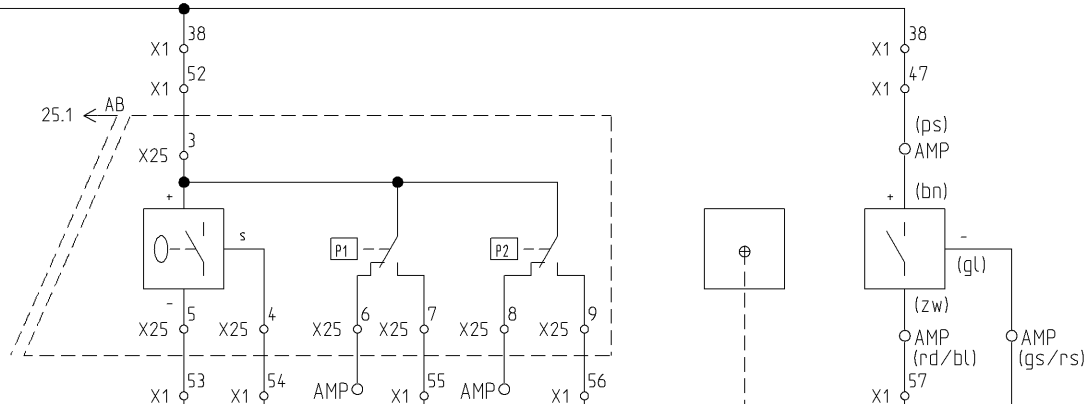

X30.0 X30.1 X30.2 X30.3 X30.4 X30.6 X30.7

Y30.0 Y30.A Y30.B Y30.C Y30.D

Bedieningkast  
Steuerpult  
Control Box

CON 5 5.0

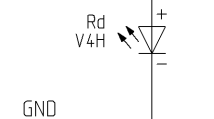

Vetpomp  
Fett Pumpe  
Grease Pump

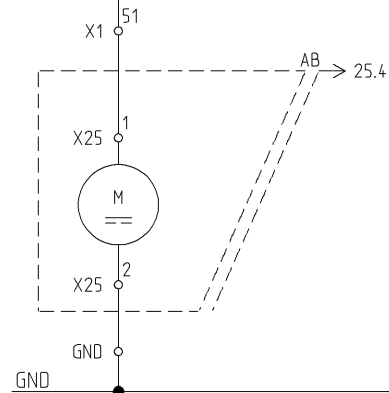

Vetpomp  
Fett Pumpe  
Grease Pump

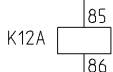

Vetpomp  
Fett Pumpe  
Grease Pump

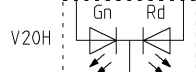

In Bedrijf  
In Betrieb  
Run  
Leeg  
Leer  
Empty

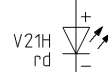

Sensor laatste Smeerpunt  
Sensor letzter Schmierpunkt  
Sensor Last Grease Point



Druk Schakelaar P1/P2  
Druck Schalter P1/P2  
Pressure Switch P1/P2

this drawing is property of Holland Lift International, by all rights reserved  
deze tekening is eigendom van Holland Lift International, by alle rechten voorbehouden volgens de wet  
deze tekening is eigendom van Holland Lift International, by auteursrecht voorbehouden volgens de wet

# HOLLAND LIFT

Holland Lift International B.V.  
Anodeweg 1  
NL-1627 LJ Hoorn The Netherlands  
T/F +31 (0)229-285555 / 285550  
E service@hollandlift.com  
W www.hollandlift.com

Optionen

Projekt:	EB-21-001	Rev.:	A
Datum:	16.06.2015	erstellt von:	Rothenbusch
Zeichnungsnummer:		Blatt:	25
Anlage:	=	Ort:	+

OPTIES  
OPTIONEN  
OPTIONS

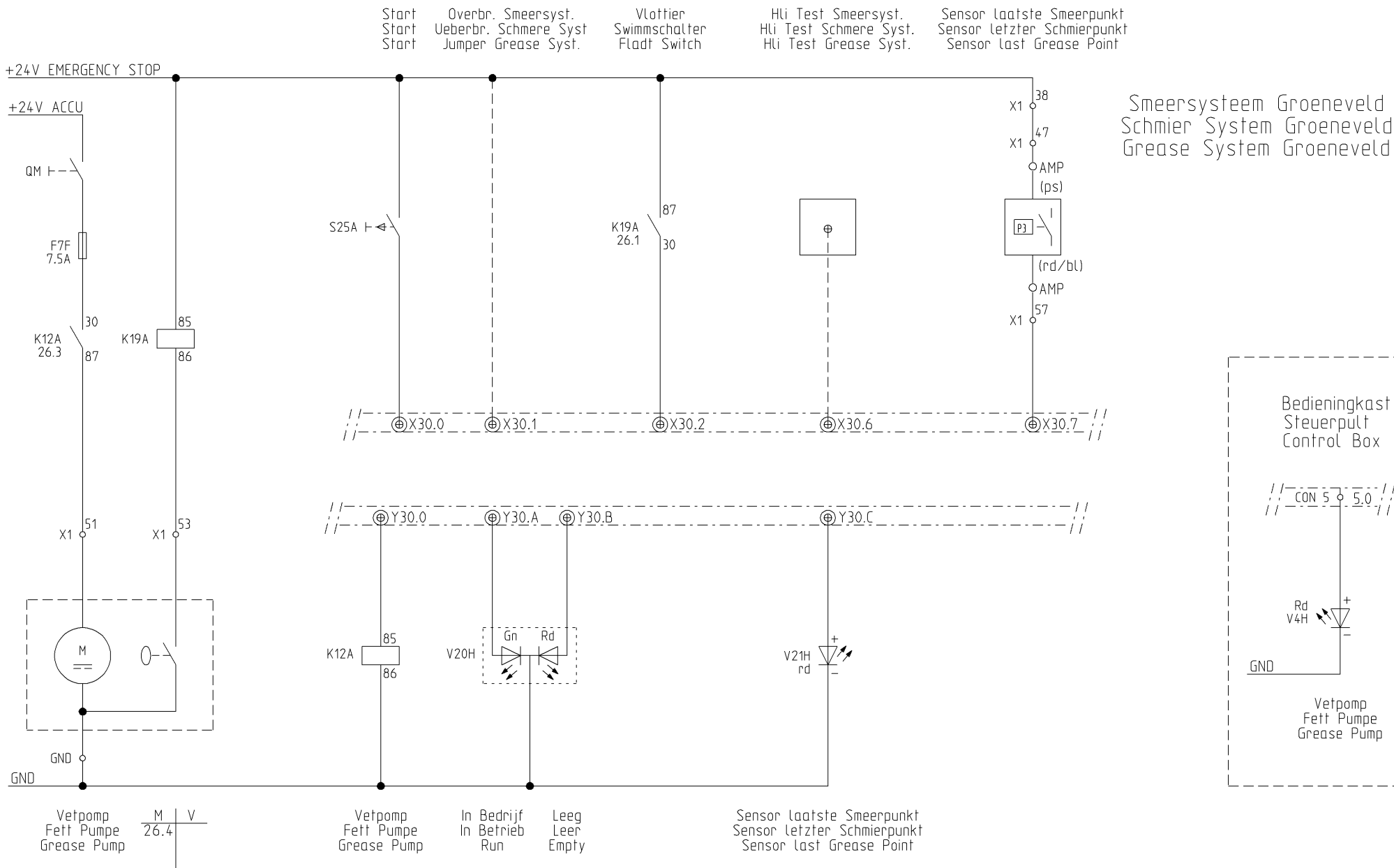

this drawing is property of Holland Lift International, by all rights reserved  
 deze tekening is eigendom van Holland Lift International, by auteursrecht voorbehouden volgens de wet

OPTIES  
OPTIONEN  
OPTIONS

KLEMMENKAST  
KLEMMENKASTEN  
CONNECTION BOX

HATZ MOTOR

23  
2/3/4/7/22  
5/14/17/18

KLEMMENKAST  
KLEMMENKASTEN  
CONNECTION BOX

DEUTZ MOTOR

1-16

OPTIE/OPTION HATZ MOTOR

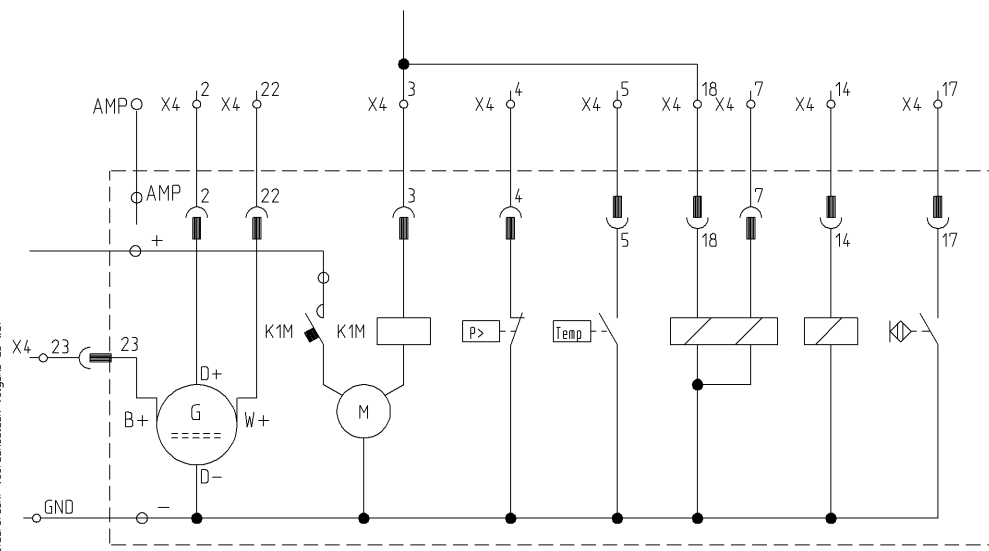

OPTIE/OPTION DEUTZ MOTOR

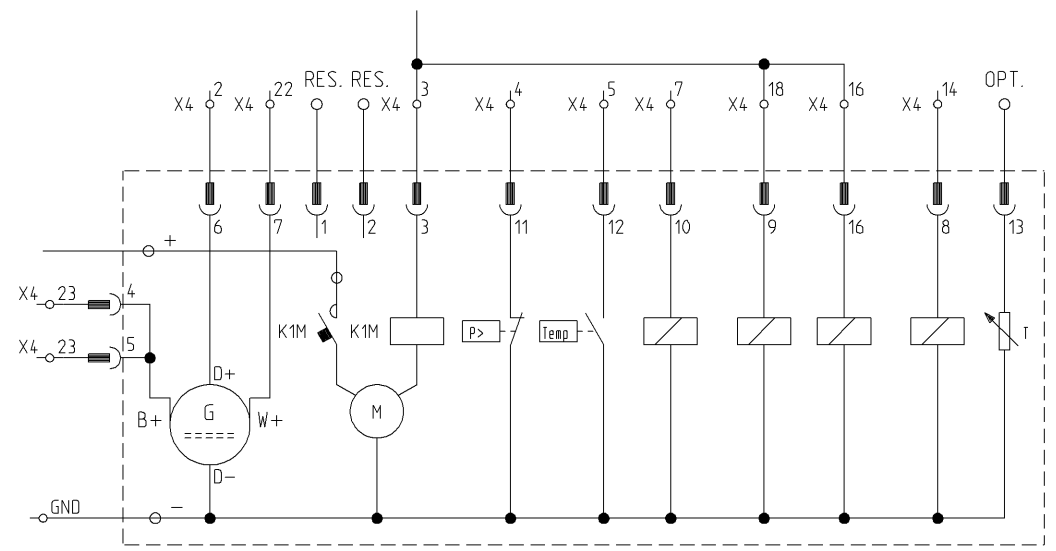

- Start Relais
- Start Relais
- Start Relay
- Oliedruk te laag
- Oelddruk zu niedrig
- Oilpressure low
- Temp. Temp.
- Start Klep
- Start Ventil
- Start Valve
- Toeren hoog/Laag
- Drehzahl hoch/niedrig
- Engine Speed high/Low
- Luchtfilter
- Luftfilter
- AIR - Filter

- Start Relais
- Start Relais
- Start Relay
- Oliedruk te laag
- Oelddruk zu niedrig
- Oilpressure low
- Temp. Temp.
- Start Klep
- Start Ventil
- Start Valve
- S. Klep koud
- S. Ventil kalt
- S. Valve cold
- Toeren ho./la.
- Drehzahl T. Sen. ho./ni.
- En. Speed Option hi./lo.

this drawing is property of Holland Lift International, by all rights reserved  
 deze tekening is eigendom van Holland Lift International, by all rights reserved  
 deze tekening is eigendom van Holland Lift International, by all rights reserved



# KLEMMENKAST KLEMMENKASTEN CONNECTION BOX

WARTEL KABELINF. GLAND NR.	KLEM KLEMME TERMINAL NR	FUNKTIE	FUNKTION	FUNCTION
1.1	φ 1	Voeding +24V	Speisung +24V	Power Supply +24V
1.2	GND	Voeding GND	Speisung GND	Power Supply GND
1.3	φ 23	+ Generator	+ Generator	+ Generator
2	DIV/VAR	Lasdoos voor X6	Verteilerdose vorn X6	Connect. Box front X6
3	DIV/VAR	Diesel	Diesel	Diesel
4.1	φ 38-GND-X4	Scheefstand	Neigung	Inclination
4.2	DIV/VAR	Auto Niv.	Auto Niv.	Auto Niv.
5.1	φ 38-GND-X5	Scheefstand Opt.	Neigung Opt.	Inclination Opt.
5.2	DIV/VAR	Koeler Opt.	Kuehler Opt.	Cooler Opt.
6.1	YA-GND	Stempels LA in	Stuetzen LH ein	Jacks LR in
6.2	YB-GND	Stempels LA uit	Stuetzen LH aus	Jacks LR out
7.1	YC-GND	Stempels RA in	Stuetzen RH ein	Jacks RR in
7.2	YD-GND	Stempels RA uit	Stuetzen RH aus	Jacks RR out
8.1	YE-GND	Stempels LV in	Stuetzen LV ein	Jacks LF in
8.2	YF-GND	Stempels LV uit	Stuetzen LV aus	Jacks LF out
9.1	YG-GND	Stempels RV in	Stuetzen RV ein	Jacks RF in
9.2	YH-GND	Stempels RV uit	Stuetzen RV aus	Jacks RF out
10	DIV/VAR	Lasdoos achter X7	Verteilerdose hinten X7	Connect. Box rear X7
11.1	Y1.2-GND	Sper/Diff. Ventiel	Sperr/Diff. Ventil	Stip/Diff. Valve
11.2	Y1.3-GND	Sper/Diff. Ventiel	Sperr/Diff. Ventil	Stip/Diff. Valve
12.1	K9A:14-GND	Snelrijden	Schnell Fahren	Driving Fast
12.2	Y1-GND	Cir. Vent Ri.-Pl.-St.	Cir. Vent. Fa.-Pl.-St.	Cir. Valve Dr.-Pl.-Ja.
13.1	K7A:14-GND	Rijden Vooruit	Fahren Vorwaerts	Driving Forward
13.2	K8A:14-GND	Rijden Achteruit	Fahren Rueckwaerts	Driving Reverse
14.1	Y1.6-GND	Heffen	Heben	Lift Up
14.2	Y1.0-GND	Cir. Ventiel Stempels	Cir. Ventil Stuetzen	Cir. Valve Jacks
15.1	Y2-GND	Sturen Links Voor	Lenken Links Vorn	Steering Left Front
15.2	Y3-GND	Sturen Rechts Voor	Lenken Rechts Vorn	Steering Right Front
16.1	Y30.6-GND	Platform in	Plattform ein	Platform in
16.2	Y30.7-GND	Platform uit	Plattform aus	Platform out
17.1	φ 58 - φ 59	Prop. Ventiel	Prop. Ventil	Prop. Valve
17.2	DIV/VAR	Frame Dieselmotor	Frame Dieselmotor	Frame Diesel Engine

WARTEL KABELINF. GLAND NR.	KLEM KLEMME TERMINAL NR	FUNKTIE	FUNKTION	FUNCTION
18.1	Y1.8-GND	Hydr. Aggregaat Opt.	Hydr. Aggr. Opt.	Hydr. Aggr. Opt.
18.2	DIV/VAR	RPM Teller Generator	RPM Zaehler Generator	RPM Meter Generator
19.1	Y1.9-GND	Relais Aggregaat Opt.	Relais Aggr. Opt.	Relais Aggr. Opt.
19.2	φ 39 -X1.4	Tank leeg	Tank Leer	Tank empty
20	DIV/VAR	WCD Onderwagen 6PM	WCD Unterwagen 6PM	Socket Below 6PM
21.1	Y0-GND	Zwaailamp Opt.	Blitzleuchte Opt.	Flashlight Opt.
21.2	Y0-GND	Zwaailamp Opt.	Blitzleuchte Opt.	Flashlight Opt.
22	DIV/VAR	Smeersytem Opt.	Schmiere System Opt.	Grease System Opt.
23	φ 39 -X1.6	Temp. Hd. Olie	Temp. Hd. Oel	Temp. Hd. Oil
24	DIV/VAR	Minidat Optie	Minidat Option	Minidat Option
25	Res./Spare			

this drawing is property of Holland Lift International, by all rights reserved  
 diese zeichnung ist eigentum von Holland Lift International, by all rights reserved  
 deze tekening is eigendom van Holland Lift International, by auteursrecht voorbehouden volgens de wet

# HOLLAND LIFT

Holland Lift International B.V.  
 Anodeweg 1  
 NL-1627 LJ Hoorn The Netherlands  
 T/F +31 (0)229-285555 / 285550  
 E service@hollandlift.com  
 W www.hollandlift.com

Kasten/Bekabelung  
 Kasten/Bekabelung  
 Boxes/Cables

Projekt:	EB-21-001	Zeichnungsnummer:	Rev.:	A	erstellt von:	Rothenbusch
Datum:	16.06.2015	Anlage:	Ort:	=	Blatt:	29
				+		

LASDOOS AFSLAGEN  
 VERTEILERDOSE HOEHEAUSSCHALTUNG  
 MAXIMUM HEIGHT DISTRBUOR BOX

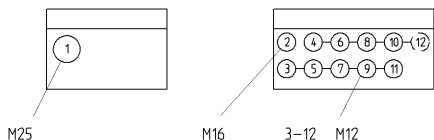
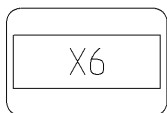

OPT.  
 <2HA>

X6

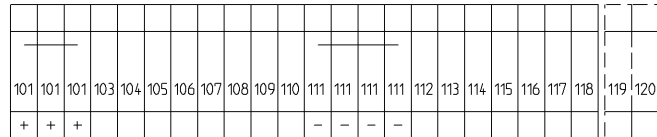

FSF

NR.	Omschrijving	Beschreibung	Descreption
1	Kabel Klemmenkast	Kabel Klemmenkasten	Cable Connection Box
2	4mtr. Afslag S1Q	4mtr. Ausschaltung S1Q	4mtr. Cut-out S1Q
3	8mtr. Afslag S2Q	8mtr. Ausschaltung S2Q	8mtr. Cut-out S2Q
4	Max. Hooqte Afslag S3Q	Max. Hoehe Ausschaltung S3Q	Max. Height Cut-out S3Q
5	Dalen	Senken	Lift Down
6	Eindschak. LV in S9Q	Endschalter LV ein S9Q	Limit Switch LF in S9Q
7	Eindschak. LV uit S13Q	Endschalter LV aus S13Q	Limit Switch LF out S13Q
8	Eindschak. RV in S10Q	Endschalter RV ein S10Q	Limit Switch RF in S10Q
9	Eindschak. RV uit S14Q	Endschalter RV aus S14Q	Limit Switch RF out S14Q
10	Druk Meting	Druck Messung	Pressure Measuring
11	Hoekmeting	Winkel Messung	Angle Measuring
12	2e hooqte Afslag Optie	2e hoehe Ausschaltung Option	2nd height cut-out Option

LASDOOS ACHTER  
 VERTEILERDOSE HINTEN  
 DISTRBUOR BOX REAR

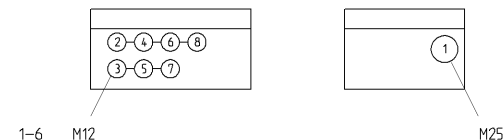
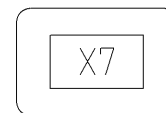

X7

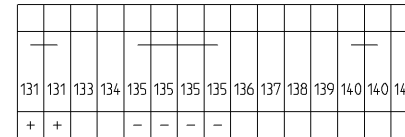

FSF

NR.	Omschrijving	Beschreibung	Descreption
1	Kabel Klemmenkast	Kabel Klemmenkasten	Cable Connection Box
2	Eindschak. LA in S11Q	Endschalter LA ein S11A	Limit Switch LR in S11Q
3	Eindschak. LA uit S15Q	Endschalter LA aus S15Q	Limit Switch LR out S15Q
4	Eindschak. RA in S12Q	Endschalter RA ein S12Q	Limit Switch RR in S12Q
5	Eindschak. RA uit S16Q	Endschalter RA aus S16Q	Limit Switch RR out S16Q
6	Pendelas Links	Pendel Achse Links	Oscillating Left
7	Pendelas Rechts	Pendel Rechts	Oscillating Right
8	Pendelas Horizontaal S18Q	Pendel Achse Hor. S18Q	Oscillating Axle S18Q

this drawing is property of Holland Lift International, by all rights reserved  
 deze tekening is eigendom van Holland Lift International, by auteursrecht voorbehouden volgens de wet  
 this drawing is property of Holland Lift International, by all rights reserved  
 diese zeichnung ist eigentum von Holland Lift International, by urheberrecht vorbehalten nach dem gesetz  
 deze tekening is eigendom van Holland Lift International, by auteursrecht voorbehouden volgens de wet

# BEDIENINGSKAST STEUERPULT CONTROL BOX

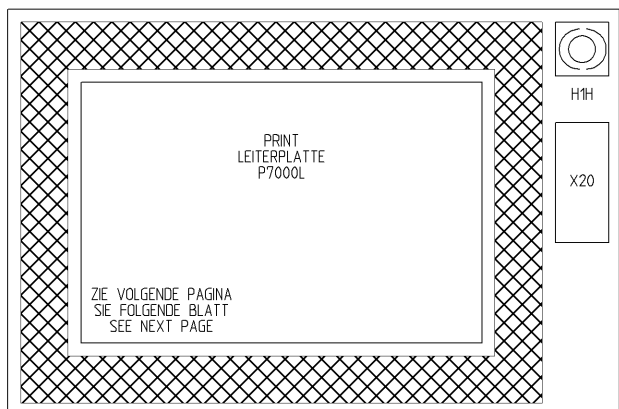
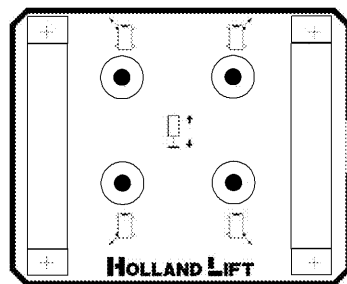
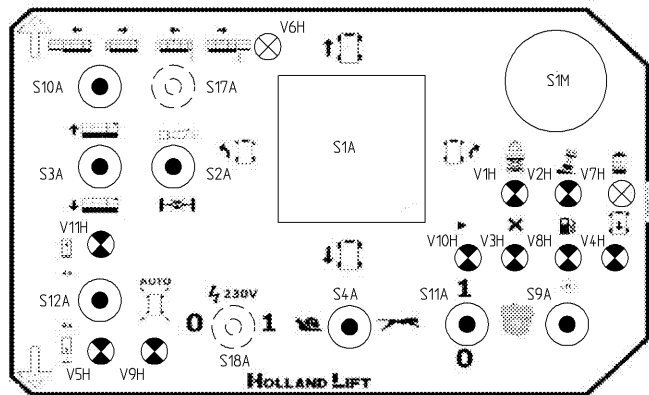

Colour schedule			
Colour	Dutch	English	Deutsch
Rd	Rood	Red	Rot
Bl	Blauw	Blue	Blau
Gl	Geel	Yellow	Gelb
Gn	Groen	Green	Gruen
Zw	Zwart	Black	Schwarz
Wt	Wit	White	Weiss
Bn	Bruin	Brown	Braun
Rs	Roze	Pink	Rosa
Or	Oranje	Orange	Orange
Ps	Poars	Violet	Violett
Tp	Transp.	Transp.	Transp.
Gs	Grijs	Grey	Grau

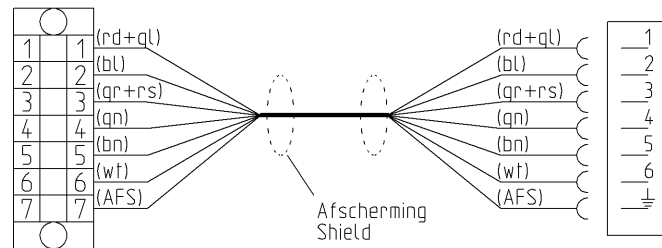
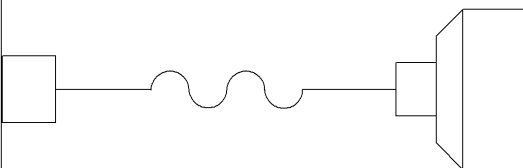

this drawing is property of Holland Lift International, by all rights reserved  
 deze tekening is eigendom van Holland Lift International, by auteursrecht voorbehouden volgens de wet  
 deze tekening is eigendom van Holland Lift International, by auteursrecht voorbehouden volgens de wet

# HOLLAND LIFT

Holland Lift International B.V.  
 Anodeweg 1  
 NL-1627 LJ Hoorn The Netherlands  
 T/F +31 (0)229-285555 / 285550  
 E service@hollandlift.com  
 W www.hollandlift.com

Kasten/Bekabelung  
 Kasten/Bekabelung  
 Boxes/Cables

Projekt: EB-21-001

Zeichnungsnummer:

Rev.: A

erstellt von:  
 Rothenbusch

Datum: 16.06.2015

Anlage: = Ort: +

Blatt: 31

PRINTPLAAT  
LEITERPLATTE  
CIRCUIT BOARD

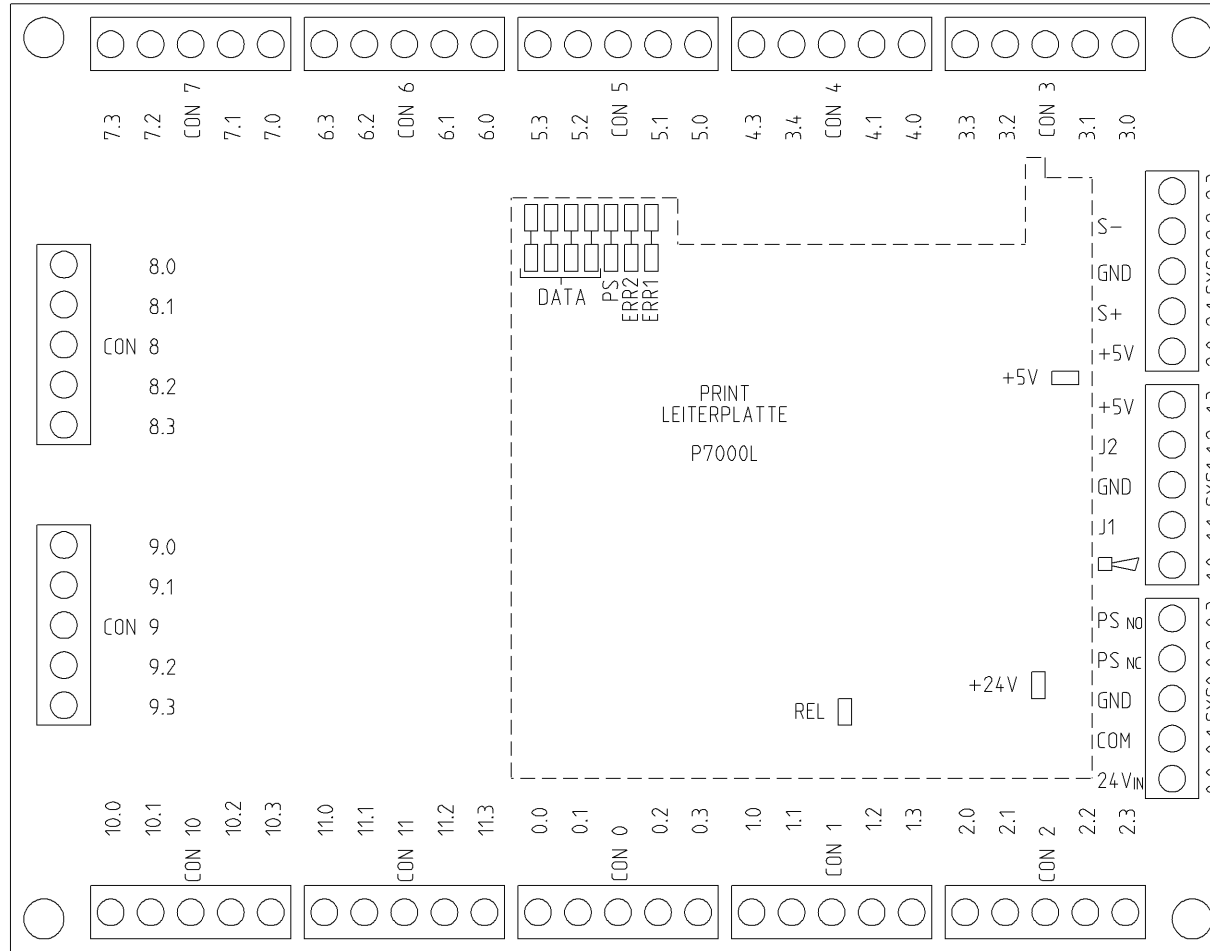

+24V	<input type="checkbox"/>	Groen/Gruen/Green	Voeding Ok	Speisung Ok	Supply Ok
+5V	<input type="checkbox"/>	Groen/Gruen/Green	Voeding Ok	Speisung Ok	Supply Ok
REL	<input type="checkbox"/>	Groen/Gruen/Green	Power Safe aan	Power Safe an	Power Safe on
PS	<input type="checkbox"/>	Geel/Gelb/Yellow	Power Safe uit	Power Safe aus	Power Safe off
Err1	<input type="checkbox"/>	Geel/Gelb/Yellow	Slechte Data Verbinding	Schlechte Data Verbindung	Poor Data Connection
Err2	<input type="checkbox"/>	Rood/Rot/Red	Geen Data Verbinding	Keine Data Verbindung	No Data Connection

this drawing is property of Holland Lift International, by all rights reserved.  
 diese zeichnung ist eigentum von Holland Lift International, by urheberrecht vorbehalten nach dem gesetz  
 deze tekening is eigendom van Holland Lift International, by auteursrecht voorbehouden volgens de wet

# HOLLAND LIFT

Holland Lift International B.V.  
 Anodeweg 1  
 NL-1627 LJ Hoorn The Netherlands  
 T/F +31 (0)229-285555 / 285550  
 E service@hollandlift.com  
 W www.hollandlift.com

Printplaat  
 Leiterplatte  
 Circuit Board

Projekt:  
 EB-21-001

Zeichnungsnummer:

Rev.:

erstellt von:  
 Rothenbusch

Datum:  
 16.06.2015

Anlage:

Ort:

Blatt:  
 32



this drawing is property of Holland Lift International, by all rights reserved.  
 deze tekening is eigendom van Holland Lift International, by all rights reserved.  
 deze tekening is eigendom van Holland Lift International, by auteursrecht voorbehouden volgens de wet

0.0	Rijden Vooruit (S1A2)	Fahren Vorwaerts (S1A2)	Driving Forward (S1A2)
0.1	Rijden Achteruit (S1A3)	Fahren Rueck. (S1A3)	Driving Reverse (S1A3)
CON 0			
0.2	Sturen Links (S1A4)	Lenken Links (S1A4)	Steering Left (S1A4)
0.3	Sturen Rechts (S1A5)	Lenken Rechts (S1A5)	Steering Right (S1A5)

1.0	Claxon (S2A1)	Hupe (S2A1)	Horn (S2A1)
1.1	Sper/Diff. (S2A3)	Sperr/Diff. (S2A3)	Slip/Diff. (S2A3)
CON 1			
1.2	Heffen (S3A1)	Heben (S3A1)	Lift Up (S3A1)
1.3	Dalen (S3A3)	Senken (S3A2)	Lift Down (S3A3)

2.0	Snel Rijden (S4A)	Schnell Fahren (S4A)	Driving Fast (S4A)
2.1	Toerental (S9A)	Drehzahl (S9A)	Enging Speed (S9A)
CON 2			
2.2	Reserve	Reserve	Spare
2.3	Dodemansknop (S1A1)	Totmansknopf (S1A1)	Dead Man (S1A1)

0.0	Voeding +24V (S1M)	Speisung +24V (S1M)	Supply +24V (S1M)
0.1	Voeding +24V (S1M)	Speisung +24V (S1M)	Supply +24V (S1M)
SYS0 GND	GND	GND	GND
0.2	Reserve	Reserve	Spare
0.3	Voeding +24V (PS)	Speisung +24V (PS)	Supply +24V (PS)

1.0	+ Zoemer (H1H)	+ Summer (H1H)	+ Buzzer (H1H)
1.1	0-5V Joystick P1	0-5V Joystick P1	0-5V Joystick P1
SYS1 GND	- Zoemer (H1H)	- Summer (H1H)	- Buzzer (H1H)
1.2	Reserve (0-5V)	Reserve (0-5V)	Spare (0-5V)
1.3	Voeding +5V Joy. (P1)	Speisung +5V Joy. (P1)	Supply +5V Joy. (P1)

2.0	Data RXD	Data RXD	Data RXD
2.1	Data S+ (RS485)	Data S+ (RS485)	Data S+ (RS485)
SYS2 GND	Reserve	Reserve	Spare
2.2	Data S- (RS485)	Data S- (RS485)	Data S- (RS485)
2.3	Data TXD	Data TXD	Data TXD

3.0	Reserve	Reserve	Spare
3.1	Reserve	Reserve	Spare
CON 3			
3.2	4x Stempels in (S12A1)	4x Stuetzen ein (S12A1)	4x Jacks in (S12A1)
3.3	4x uit Au. Niv. (S12A3)	4x aus Au. Niv. (S12S3)	4x out Au. Niv.(S12A3)

4.0	Plat. acht. in (S10A1)	Plat. hinten ein (S10A1)	Plat. rear in (S10A1)
4.1	Plat. acht. uit (S10A3)	Plat. hinten aus (S10A3)	Plat. rear out (S10A3)
CON 4			
4.2	Plat. voor in (S17A1)	Plat. vorn ein (S17A1)	Plat. front in (S17A1)
4.3	Plat. voor uit (S17A3)	Plat. vorn aus (S17A3)	Plat. front out (S17A3)

5.0	Vetpomp Opt. (V7H)	Fett Pumpe Opt. (V7H)	Grease Pu. Opt. (V7H)
5.1	Overload (V1H)	Ueberlastung (V1H)	Overload (V1H)
CON 5			
5.2	Scheefstand (V2H)	Neigung (V2H)	Inclination (V2H)
5.3	Tank leeg (V8H)	Tank leer (V8H)	Tank empty (V8H)

6.0	Start Motor (S11A1)	Start Motor (S11A1)	Start Engine (S11A1)
6.1	Stop Motor (S11A3)	Halte Motor (S11A3)	Stop Engine (S11A3)
CON 6			
6.2	Gen. aan Opt. (S18A1)	Gen. an Opt. (S18A1)	Gen. on Opt. (S18A1)
6.3	Gen. uit Opt. (S18A3)	Gen. aus Opt. (S18A3)	Gen. off Opt. (S18A3)

7.0	Stempels LA in (S15A1)	Stuetzen LH ein (S15A1)	Jacks LR in (S15A1)
7.1	Stemp. LA uit (S15A3)	Stuetzen LH aus (S15A3)	Jacks LR out (S15A3)
CON 7			
7.2	Stempels RA in (S16A1)	Stuetzen RH ein (S16A1)	Jacks RR in (S16A1)
7.3	Stemp. RA uit (S16A3)	Stuetzen RH aus (S16A3)	Jacks RR out (S16A3)

8.0	Stempels LV in (S13A1)	Stuetzen LV ein (S13A1)	Jacks LF in (S13A1)
8.1	Stemp. LV uit (S13A3)	Stuetzen LV aus (S13A3)	Jacks LF out (S13A3)
CON 8			
8.2	Stempels RV in (S14A1)	Stuetzen RV ein (S14A1)	Jacks RF in (S14A1)
8.3	Stemp. RV uit (S14A3)	Stuetzen RV aus (S14A3)	Jacks RF out (S14A3)

9.0	Reserve	Reserve	Spare
9.1	Stempels in (V11H)	Stuetzen ein (V11H)	Jacks in (V11H)
CON 9			
9.2	Stempels uit (V5H)	Stuetzen aus (V5H)	Jacks out (V5H)
9.3	Auto Niv. (V9H)	Auto Niv. (V9H)	Auto Niv. (V9H)

10.0	In Bedrijf (V10H)	In Betrieb (V10H)	Run (V10H)
10.1	Storing Dieselm. (V3H)	Stoerung Dieselm. (V3H)	Failure Dieselm. (V3H)
CON 10			
10.2	Pendelas Hor. (V4H)	Pendel Achse Hor. (V4H)	Os. Axle Hor. (V4H)
10.3	Plat. vo. in Opt. (V6H)	Plat. vo. ein Opt. (V6H)	Plat. fr. in Opt. (V6H)

11.0	Reserve	Reserve	Spare
11.1	Reserve	Reserve	Spare
CON 11			
11.2	Reserve	Reserve	Spare
11.3	Reserve	Reserve	Spare



Holland Lift International B.V.  
 Anodeweg 1  
 NL-1627 LJ Hoorn The Netherlands  
 T/F +31 (0)229-285555 / 285550  
 E service@hollandlift.com  
 W www.hollandlift.com

Printplaat  
 Leiterplatte  
 Circuit Board

Projekt:	EB-21-001	Zeichnungsnummer:	Rev.:	A	erstelt von:	Rothenbusch
Datum:	16.06.2015	Antage:	Ort:	+	Blatt:	33