

this drawing is property of Holland Lift International. All rights reserved.
 deze tekening is eigendom van Holland Lift International. Alle rechten voorbehouden.
 diese Zeichnung ist Eigentum von Holland Lift International. Alle Rechte vorbehalten.
 diese tekening is eigendom van Holland Lift International. Alle rechten voorbehouden volgens de wet

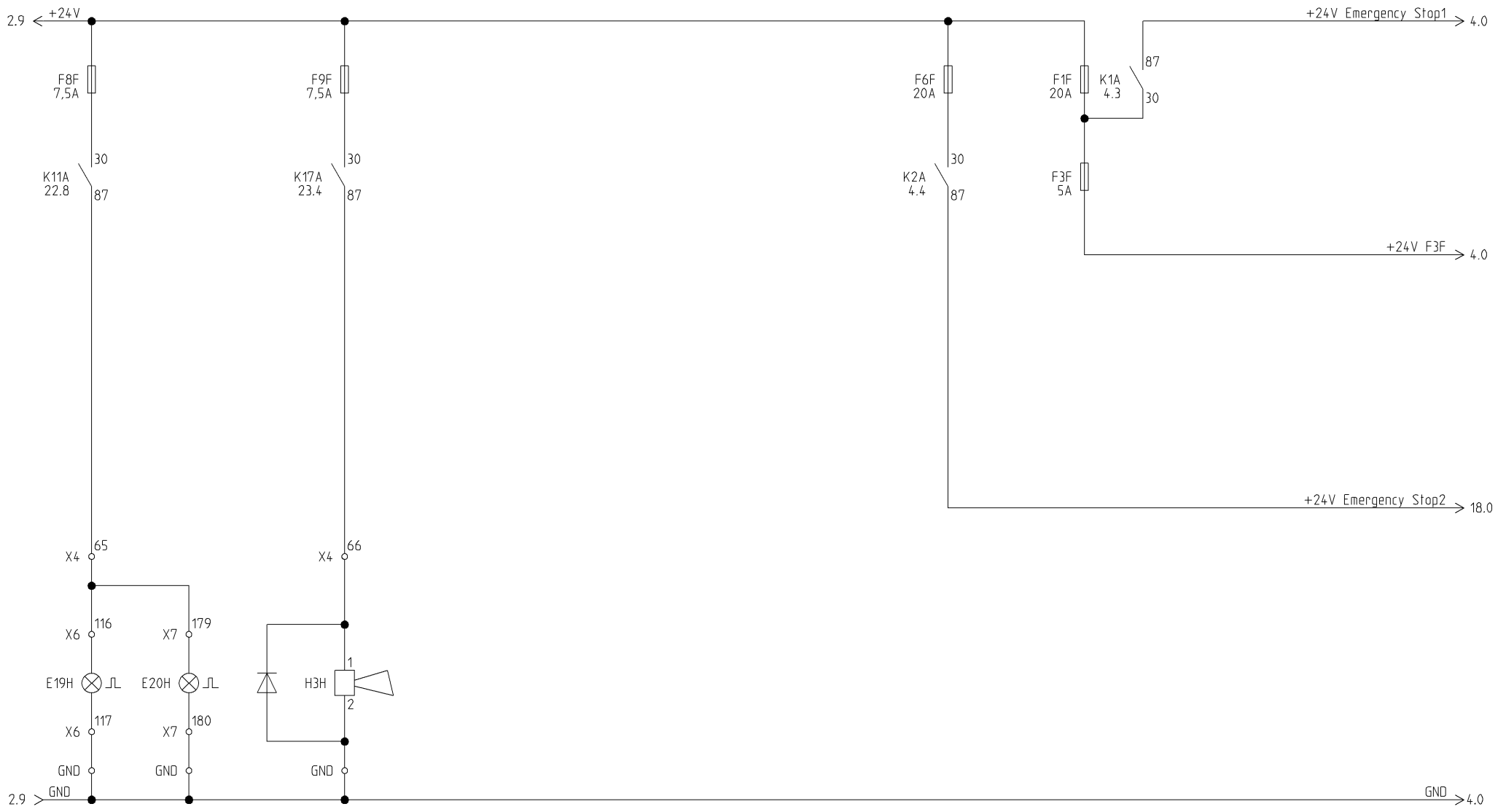

Voor-Zwaalampen-Achter
 Vorn-Blitzleuchten-Hinten
 Front-Flashlights-Rear

Claxon
 Hupe
 Horn

Nood-Stop
 Not-Aus
 Emergency Stop

Nood-Stop
 Not-Aus
 Emergency Stop



Holland Lift International B.V.
 Anodeweg 1
 NL-1627 LJ Hoorn The Netherlands
 T/F +31 (0)229-285555 / 285550
 E service@hollandlift.com
 W www.hollandlift.com

Blitzleuchten
 Hupe
 Not-Aus

Projekt:	EG-20-001	Zeichnungsnummer:	Rev.:	A	erstellt von:	Rothenbusch	
Datum:	28.06.2013	Anlage:	=	Ort:	+	Blatt:	3

this drawing is property of Holland Lift International, by all rights reserved
 deze tekening is eigendom van Holland Lift International, by all rights reserved
 deze tekening is eigendom van Holland Lift International, by all rights reserved

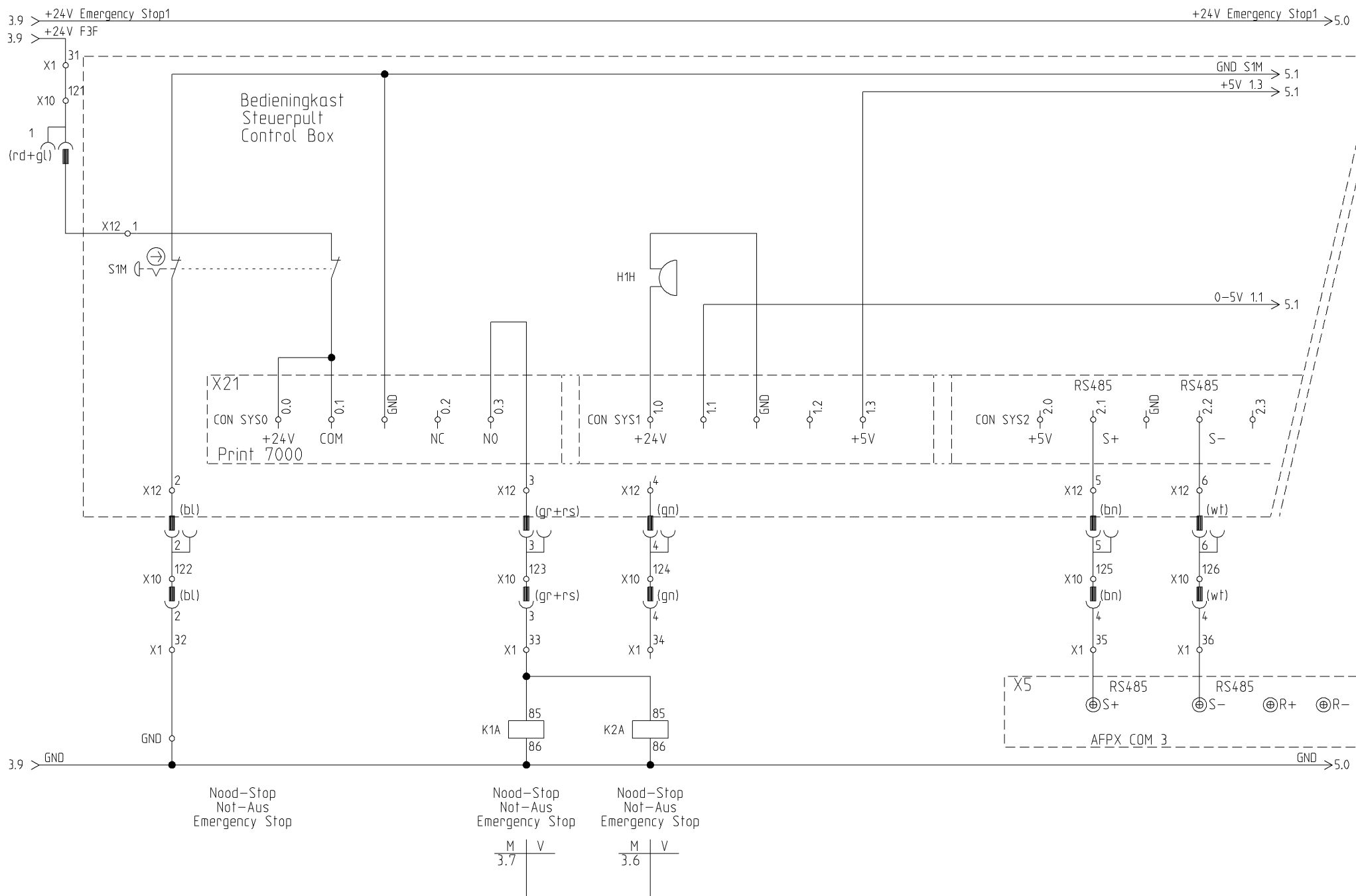

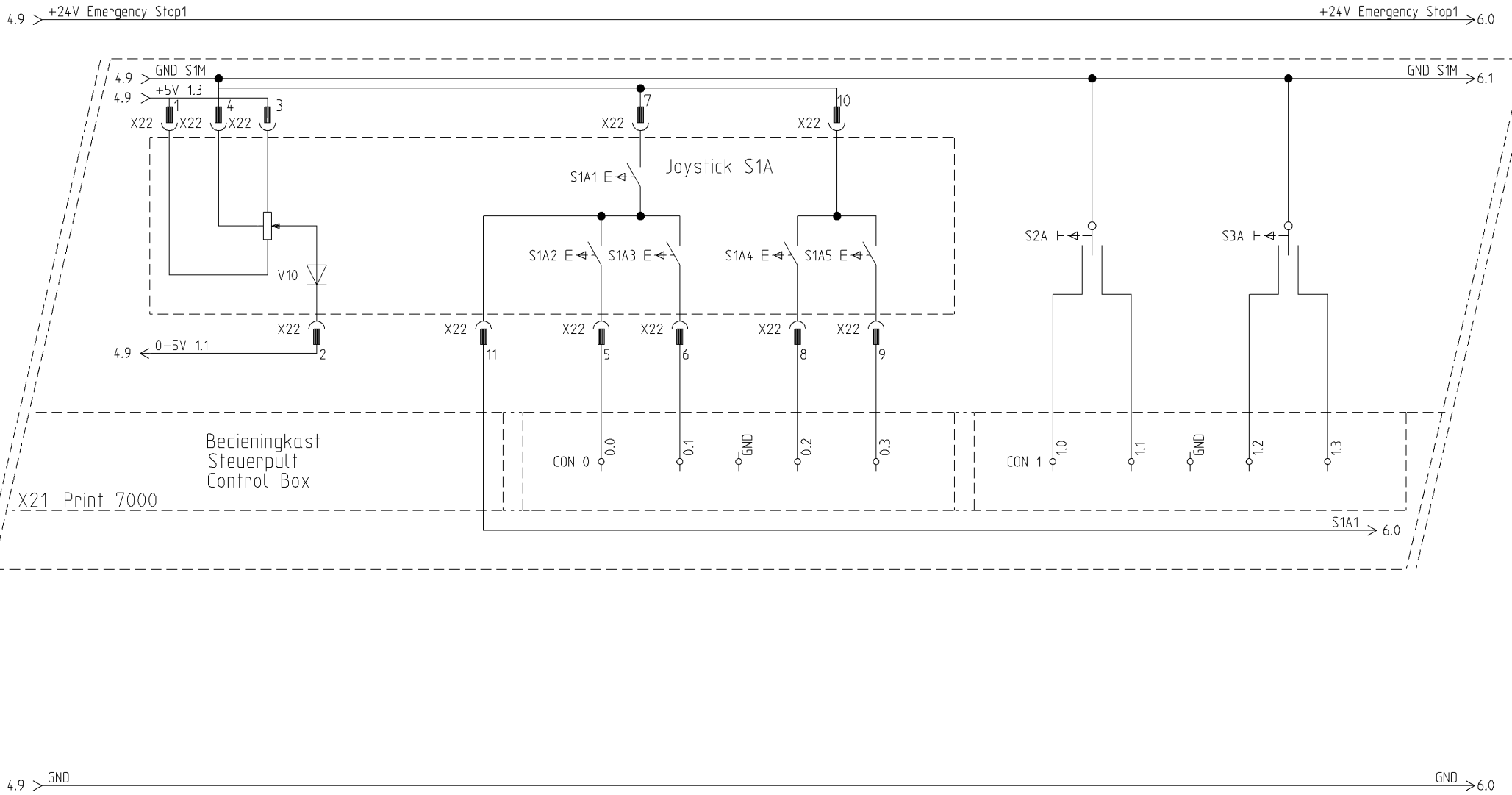

Bedieningkast
Steuerpult
Control Box

X21 Print 7000

S1A1 Dodemansknop
S1A1 Totmansknop
S1A1 Dead Man,s Button

Op-Joysick-Neer
Auf-Joystick-Nieder
On-Joystick-Down

Links - Rechts
Links - Rechts
Left - Right

Claxon-Sign.gever
Hupe-Signalgeber
Horn-Signal

Sper/Diff
Sperr/Diff
Slip/Diff

Rijden-Heffen-Platf.
Fahren-Heben-Platf.
Driving-Lifting-Platf.

Sturen Voor
Lenken Vorn
Steering Front

— Mode Select —

this drawing is property of Holland Lift International, by all rights reserved
 diese zeichnung ist eigentum von Holland Lift International, by urheberrecht vorbehalten
 deze tekening is eigendom van Holland Lift International, by auteursrecht voorbehouden volgens de wet



Holland Lift International B.V.
Anodeweg 1
NL-1627 LJ Hoorn The Netherlands
T/F +31 (0)229-285555 / 285550
E service@hollandlift.com
W www.hollandlift.com

Bedienpult
CON 0 - 1

Projekt: EG-20-001
Datum: 28.06.2013

Zeichnungsnummer:
Anlage: =

Rev.: A
Ort: +

erstellt von:
Rothenbusch
Blatt: 5

5.9 > +24V Emergency Stop1 +24V Emergency Stop1 > 7.0

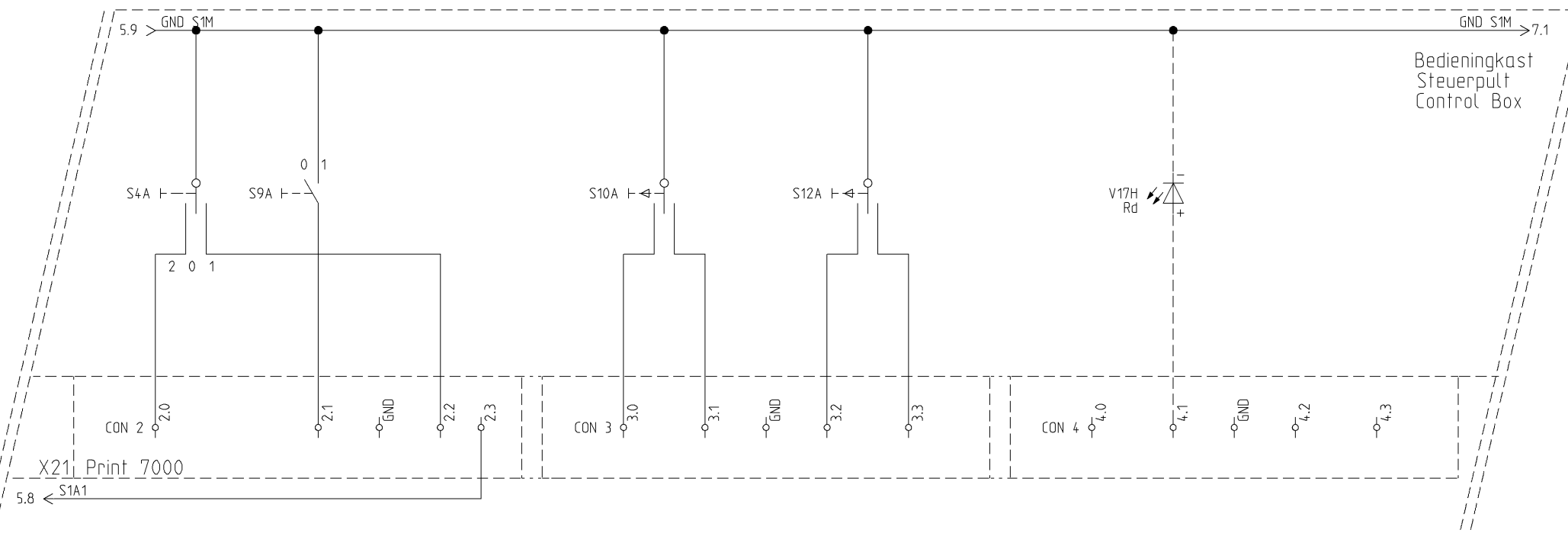

Bedieningkast
Steuerpult
Control Box

S4A		
0 = Langzaam	Langsam	Slow
1 = Normal	Normal	Normal
2 = Snel	Schnell	Fast

S9A		
0 = Laag	Niedrig	Low
1 = Autom.	Autom.	Autom.

5.9 > GND GND > 7.0

- | | | | | | |
|--------------------------------------|---------------------------------------|--|--|---|--|
| Snelheid
Geschwindigkeit
Speed | Toerental
Drehzahl
Enging Speed | S1A1 Dodemansknop
S1A1 Totmansknopf
S1A1 Dead Man,s Button | Links - Rechts
Links - Rechts
Left - Right | 4xN-Stempels-Autom. Niveleer
4xN-Stuetzen-Autom. Nivel.
4xN-Jack-Autom. Nivel | Generator aan
Generator ein
Generator on
Optie/Option |
| | | | Sturen Achter
Lenken Hinten
Steering Rear | | |

this drawing is property of Holland Lift International, by all rights reserved
 diese zeichnung ist eigentum von Holland Lift International, by alle rechte vorbehalten nach dem gesetz
 deze tekening is eigendom van Holland Lift International, by auteursrecht voorbehouden volgens de wet



Holland Lift International B.V.
Anodeweg 1
NL-1627 LJ Hoorn The Netherlands
T/F +31 (0)229-285555 / 285550
E service@hollandlift.com
W www.hollandlift.com

Bedienpult
CON 2 - 4

Projekt: EG-20-001	Zeichnungsnummer:	Rev.: A	erstellt von: Rothenbusch
Datum: 28.06.2013	Anlage: =	Ort: +	Blatt: 6

6.9 > +24V Emergency Stop1 +24V Emergency Stop1 > 8.0

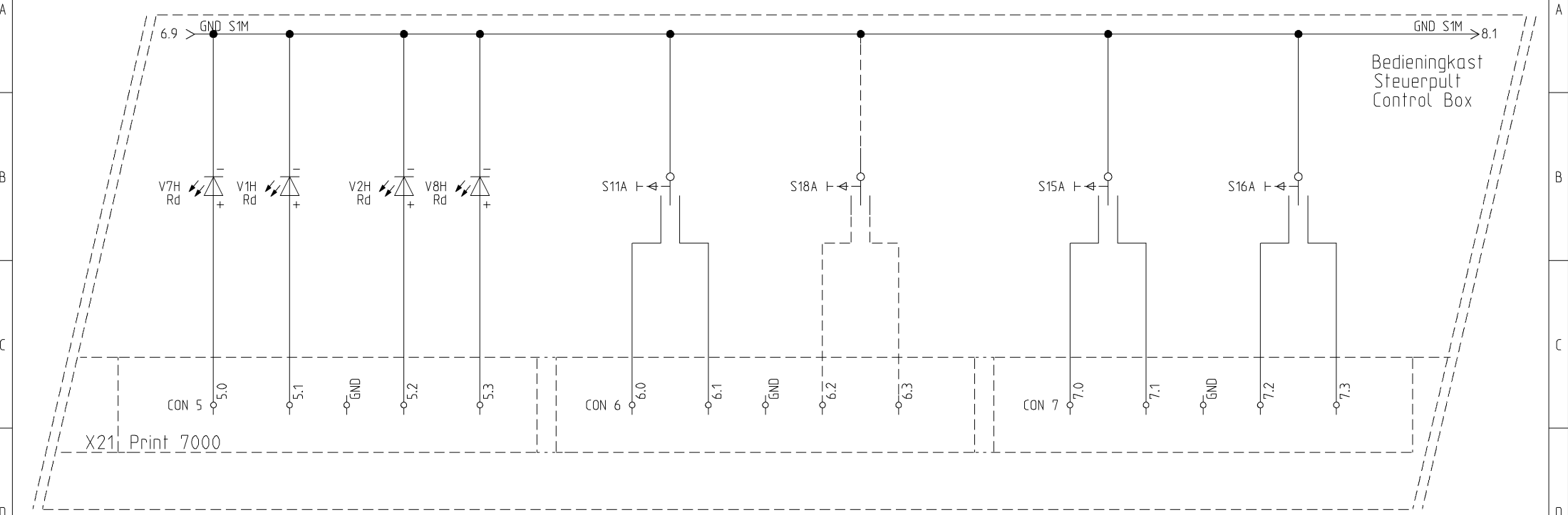

this drawing is property of Holland Lift International, by all rights reserved
 deze tekening is eigendom van Holland Lift International, by auteursrecht voorbehouden volgens de wet
 deze tekening is eigendom van Holland Lift International, by auteursrecht voorbehouden volgens de wet

6.9 > GND GND > 8.0

Vetpomp	Overload	Scheefstand	Tank leeg
Fett Pumpe	Ueberlastung	Neigung	Tank leer
Grease Pump	Overload	Grade/Slope	Tank empty

Start	- Motor - Stop	Aan	Generator	Uit
Start	- Motor - Halt	An	Generator	Aus
Start	- Engine - Stop	On	Generator	Off

LA in	LA uit	RA in	RA uit
LH ein	LH aus	RH ein	RH aus
LR in	LR out	RR in	RR out

Optie/Option

Stempels-Stuetzen-Jacks Stempels-Stuetzen-Jacks

7.9 > +24V Emergency Stop1 +24V Emergency Stop1 > 9.0

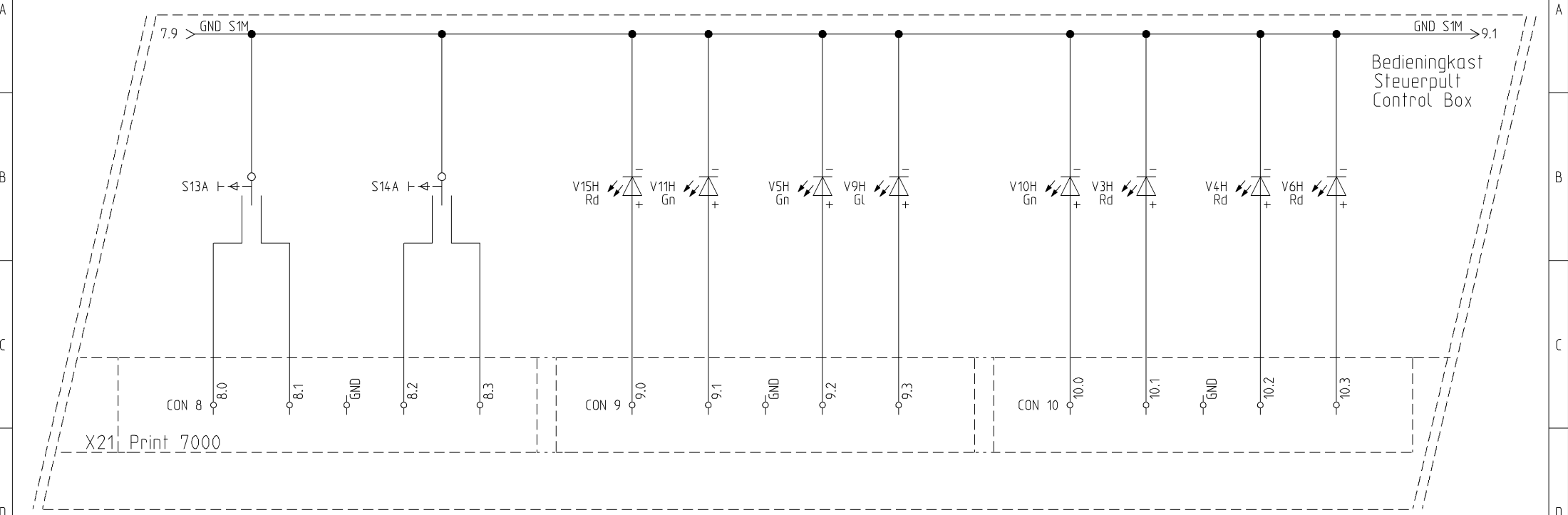

X21, Print 7000

Bedieningkast
Steuerpult
Control Box

7.9 > GND GND > 9.0

LV in LV ein LF in	LV uit LV aus LF out	RV in RV ein RF in	RV uit RV aus RF out	8 mtr. Afslag 8 mtr. Ausschält. 8 mtr. Cut-Out	Stempels in Stuetzen ein Jacks in	Stempels uit Stuetzen aus Jacks out	Autom. Niv. Autom. Niv. Autom. Niv.	In Bedrijf In Betrieb Run	Storing Stoerung Failure	Achteras Hinten Rear	Horizontaal Achse Hor. Axle Hor.	Platform uit Plattform aus Platform out
Stempels-Stuetzen-Jacks						Diesel Motor						

this drawing is property of Holland Lift International, by all rights reserved
 deze tekening is eigendom van Holland Lift International, by all rights reserved
 deze tekening is eigendom van Holland Lift International, by auteursrecht voorbehouden volgens de wet



Holland Lift International B.V.
 Anodeweg 1
 NL-1627 LJ Hoorn The Netherlands
 T/F +31 (0)229-285555 / 285550
 E service@hollandlift.com
 W www.hollandlift.com

Bedienpult
CON 8 - 10

Projekt: EG-20-001	Zeichnungsnummer:	Rev.: A	erstellt von: Rothenbusch
Datum: 28.06.2013	Anlage: =	Ort: +	Blatt: 8

this drawing is property of Holland Lift International, by all rights reserved
 deze tekening is eigendom van Holland Lift International, by all rights reserved
 deze tekening is eigendom van Holland Lift International, by auteursrecht voorbehouden volgens de wet

8.9 > +24V Emergency Stop1 +24V Emergency Stop1 > 10.0

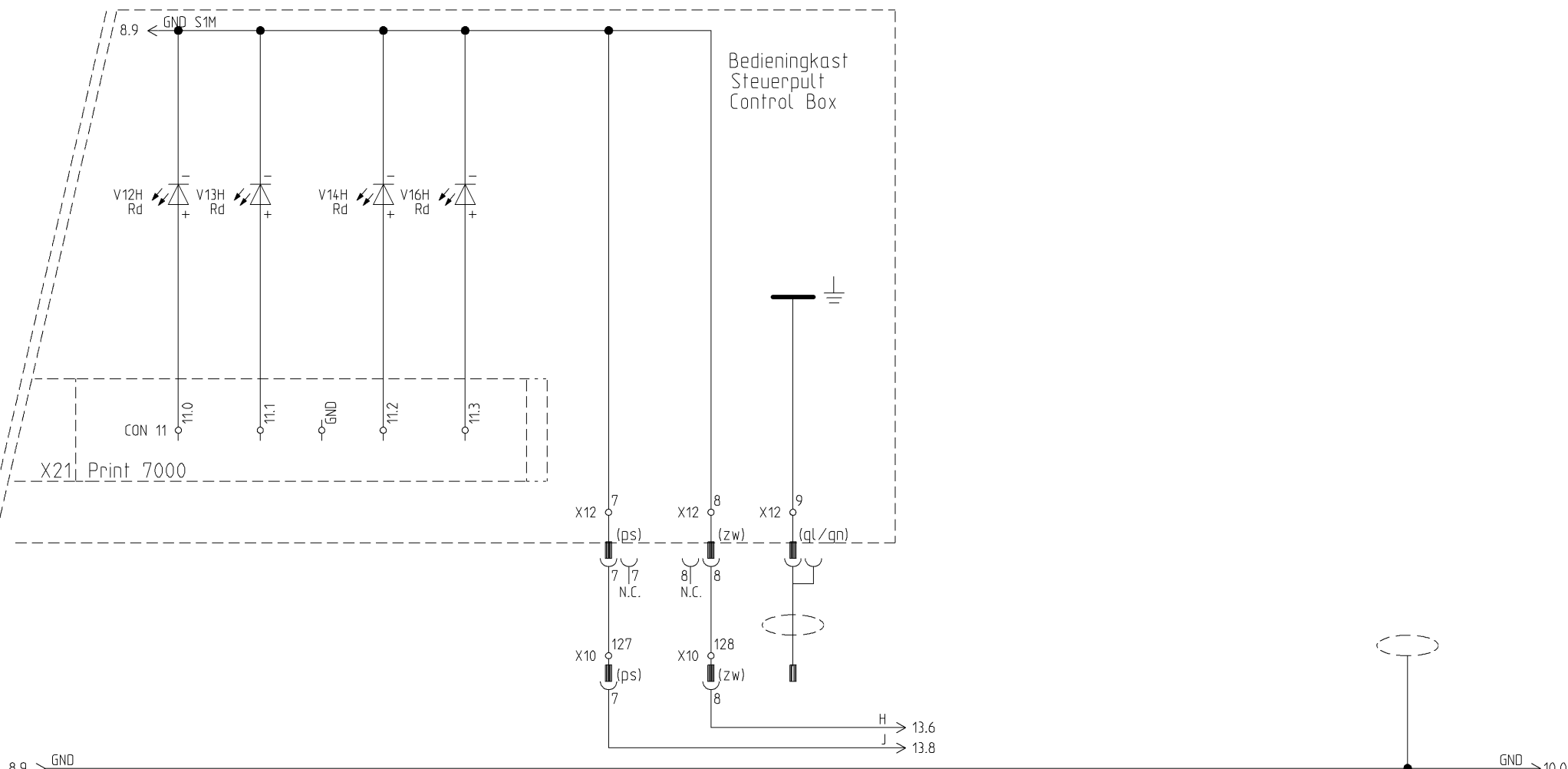

Bedieningkast
Steuerpult
Control Box

X21, Print 7000

Rijden Fahren Driving
 Heffen Heben Lifting
 Plattform Plattform Platform
 Delta P C1L1/C1L2
 WDC Voor Vornn Steckd. Front Socket
 WDC Achter Hinten Steckd. Rear Socket
 Mode Select

Afscherm. Kabel
Abschirm. Kabel
Cable Screen



Holland Lift International B.V.
 Anodeweg 1
 NL-1627 LJ Hoorn The Netherlands
 T/F +31 (0)229-285555 / 285550
 E service@hollandlift.com
 W www.hollandlift.com

Bedienpult
CON 11

Projekt:	EG-20-001	Zeichnungsnummer:	Rev.:	A	erstellt von:	Rothenbusch
Datum:	28.06.2013	Anlage:	Ort:	=	Blatt:	9

this drawing is property of Holland Lift International, by all rights reserved.
 deze tekening is eigendom van Holland Lift International, by all rights reserved.
 deze tekening is eigendom van Holland Lift International, by all rights reserved.

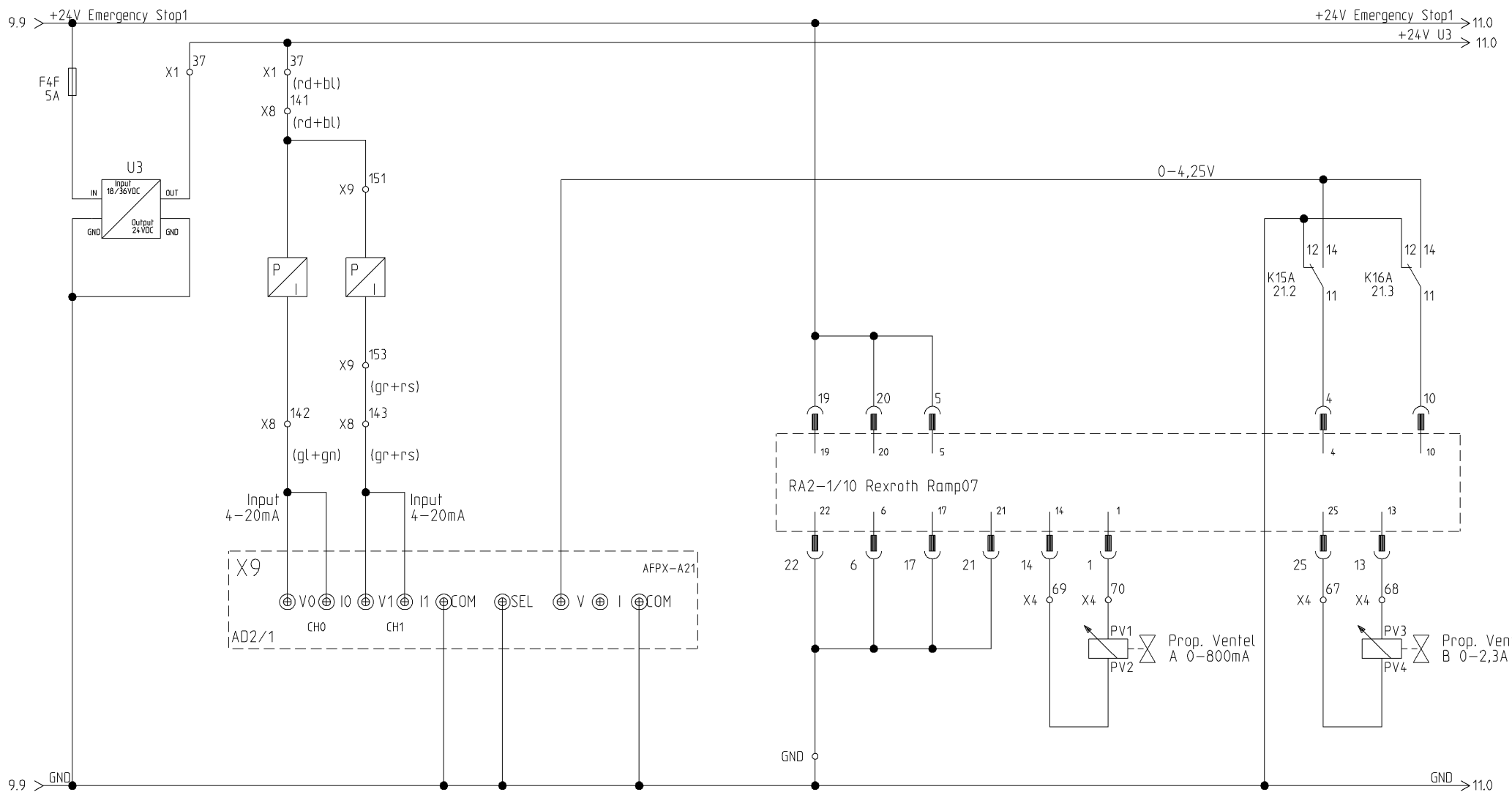

Druk Meting Cyl. 1 Druk Meting Cyl. 2
 Druck Messung Zyl. 1 Druck Messung Zyl. 2
 Pressure Measuring Cyl. 1 Pressure Measuring Cyl. 2

Rijden/Heffen/Stempels/Platform/Gen.
 Fahren/Heben/Stuetzen/Plattform/Gen.
 Driving/Lifting/Jacks/Plattform/Gen.

Dalen
 Senken
 Lift Down

this drawing is property of Holland Lift International, by all rights reserved.
 deze tekening is eigendom van Holland Lift International, by auteursrecht voorbehouden volgens de wet.
 deze tekening is eigendom van Holland Lift International, by auteursrecht voorbehouden volgens de wet.

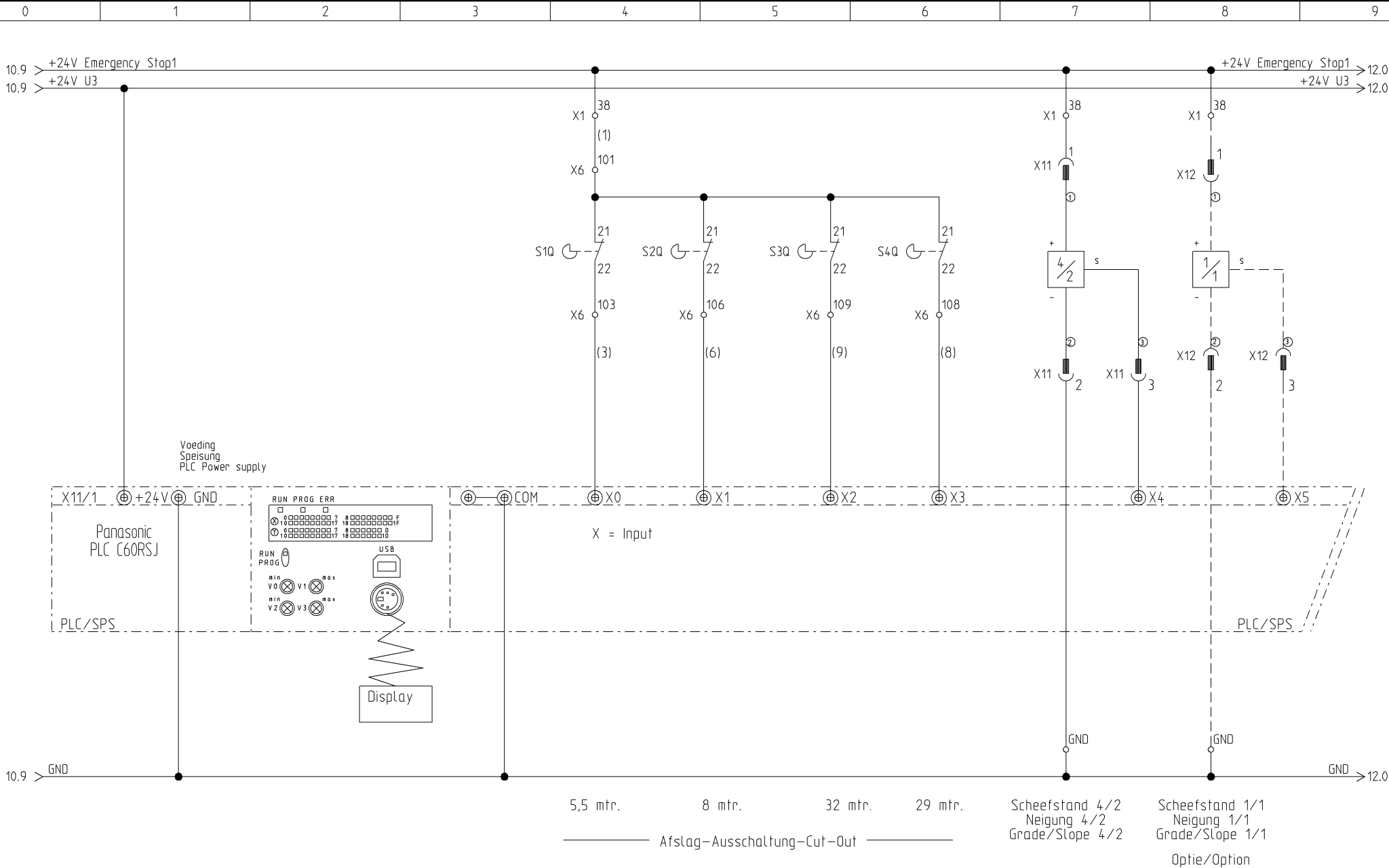

this drawing is property of Holland Lift International, by all rights reserved
 deze tekening is eigendom van Holland Lift International, by all rights reserved
 deze tekening is eigendom van Holland Lift International, by all rights reserved

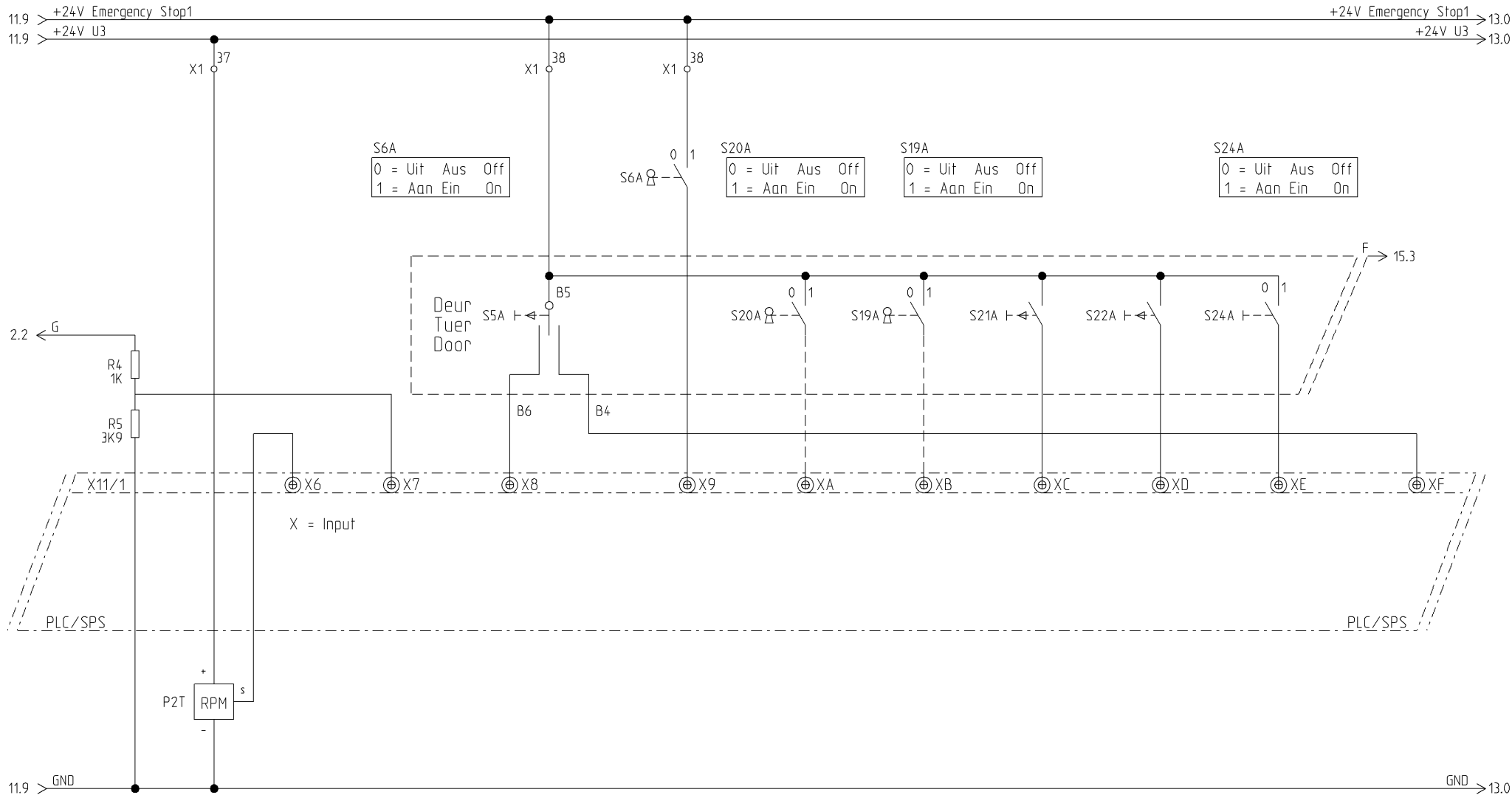

RPM Teller Gen. RPM Zaehler Gen. RPM Meter Gen.	W+ Dieselmotor	Dalen Senken Liff Down	Overlastin Ueberlastung Overload	Ri. max. Hoogte Fa. max. Hoehe Dr. max. Height	Af. 2e Hoogte Au. 2e Hoehe Cut. 2e Height	Start - Motor - Stop Start - Motor - Halt Start - Engine - Stop	Overbr. Plattf. in Ueberbr. Plattf. ein Override Plattf. in	Heffen Heben Lift Up
---	----------------	------------------------------	--	--	---	---	---	----------------------------

Optie/Option Optie/Option



Holland Lift International B.V.
 Anodeweg 1
 NL-1627 LJ Haarn The Netherlands
 T/F +31 (0)229-285555 / 285550
 E service@hollandlift.com
 W www.hollandlift.com

SPS Input
X6 - XF

Projekt: EG-20-001	Zeichnungsnummer:	Rev.: A	erstellt von: Rothenbusch
Datum: 28.06.2013	Anlage: =	Ort: +	Blatt: 12

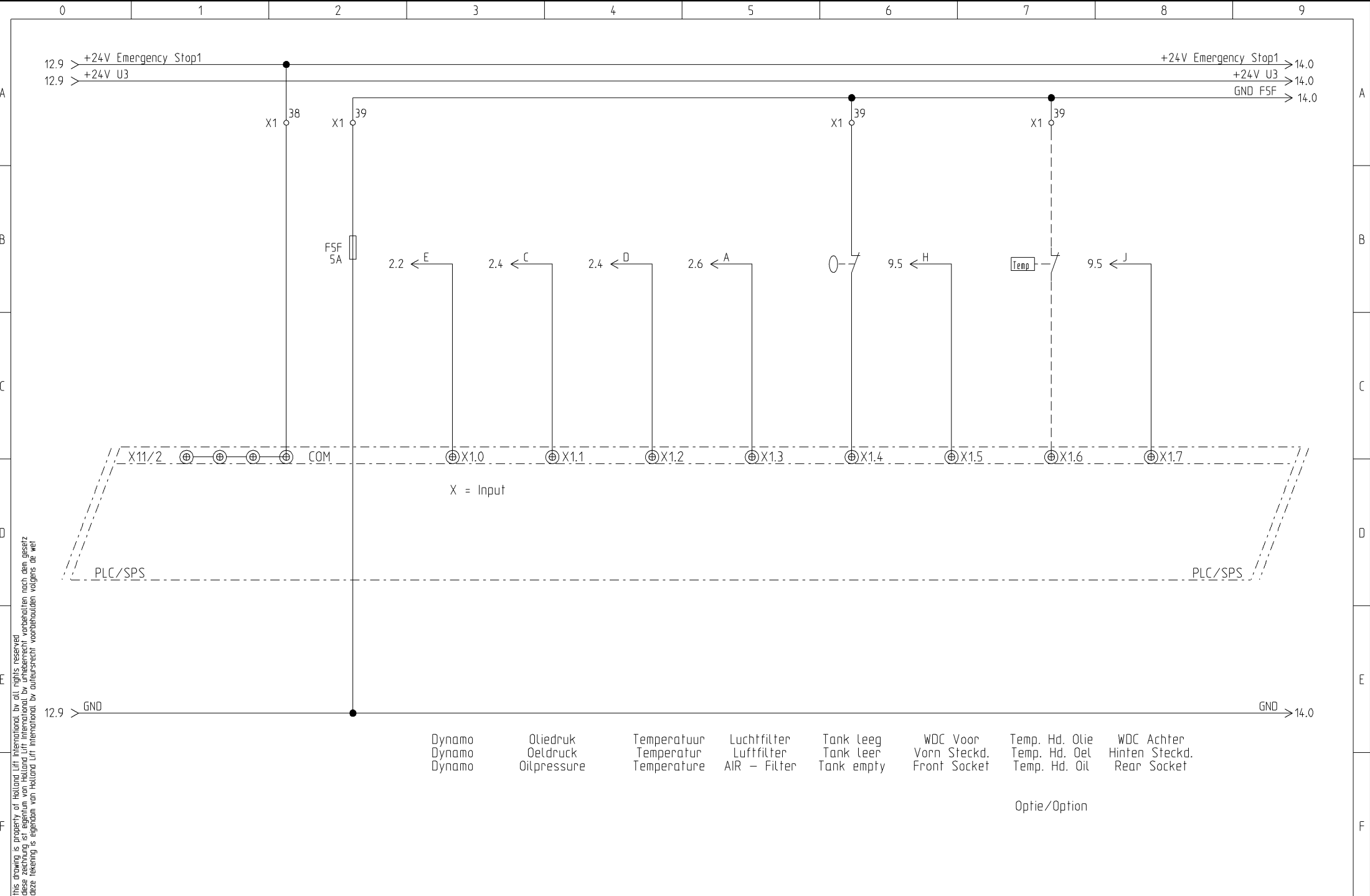

this drawing is property of Holland Lift International B.V. all rights reserved
 deze tekening is eigendom van Holland Lift International B.V. alle rechten voorbehouden
 deze tekening is eigendom van Holland Lift International B.V. alle rechten voorbehouden volgens de wet



Holland Lift International B.V.
 Anodeweg 1
 NL-1627 LJ Hoorn The Netherlands
 T/F +31 (0)229-285555 / 285550
 E service@hollandlift.com
 W www.hollandlift.com

SPS Input
 X1.0 - X1.7

Projekt: EG-20-001
 Datum: 28.06.2013

Zeichnungsnummer:
 Anlage: =

Rev.: A
 Ort: +

erstellt von: Rothenbusch
 Blatt: 13

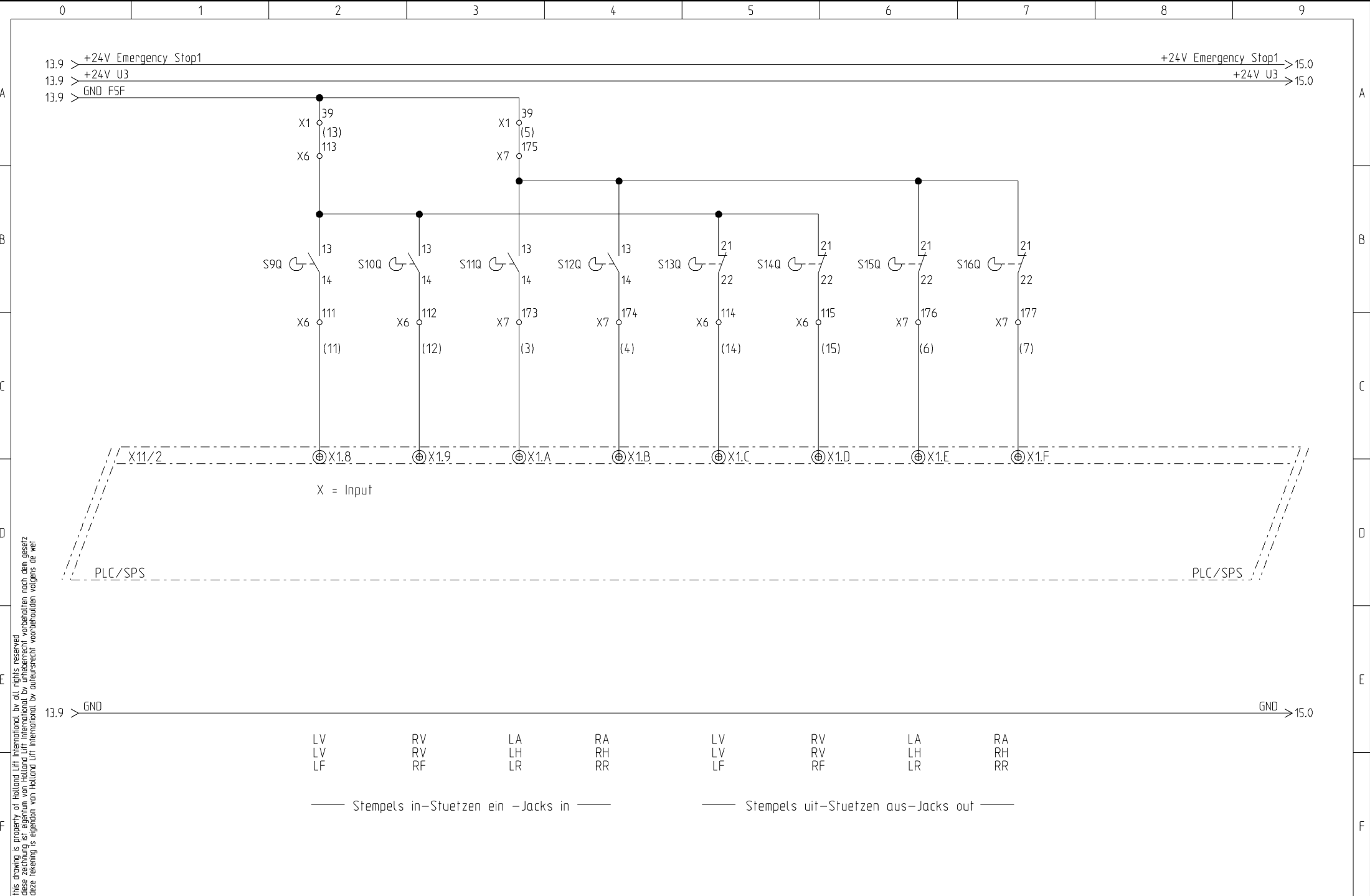

this drawing is property of Holland Lift International, by all rights reserved.
 deze tekening is eigendom van Holland Lift International, by all rights reserved.
 deze tekening is eigendom van Holland Lift International, by all rights reserved.



Holland Lift International B.V.
 Anodeweg 1
 NL-1627 LJ Hoorn The Netherlands
 T/F +31 (0)229-285555 / 285550
 E service@hollandlift.com
 W www.hollandlift.com

SPS Input
 X1.8 - X1.F

Projekt: EG-20-001
 Datum: 28.06.2013

Zeichnungsnummer:
 Anlage: =

Rev.: A
 Ort: +

erstellt von:
 Rothenbusch
 Blatt: 14

this drawing is property of Holland Lift International, by all rights reserved
 deze tekening is eigendom van Holland Lift International, by auteursrecht voorbehouden volgens de wet
 deze tekening is eigendom van Holland Lift International, by auteursrecht voorbehouden volgens de wet

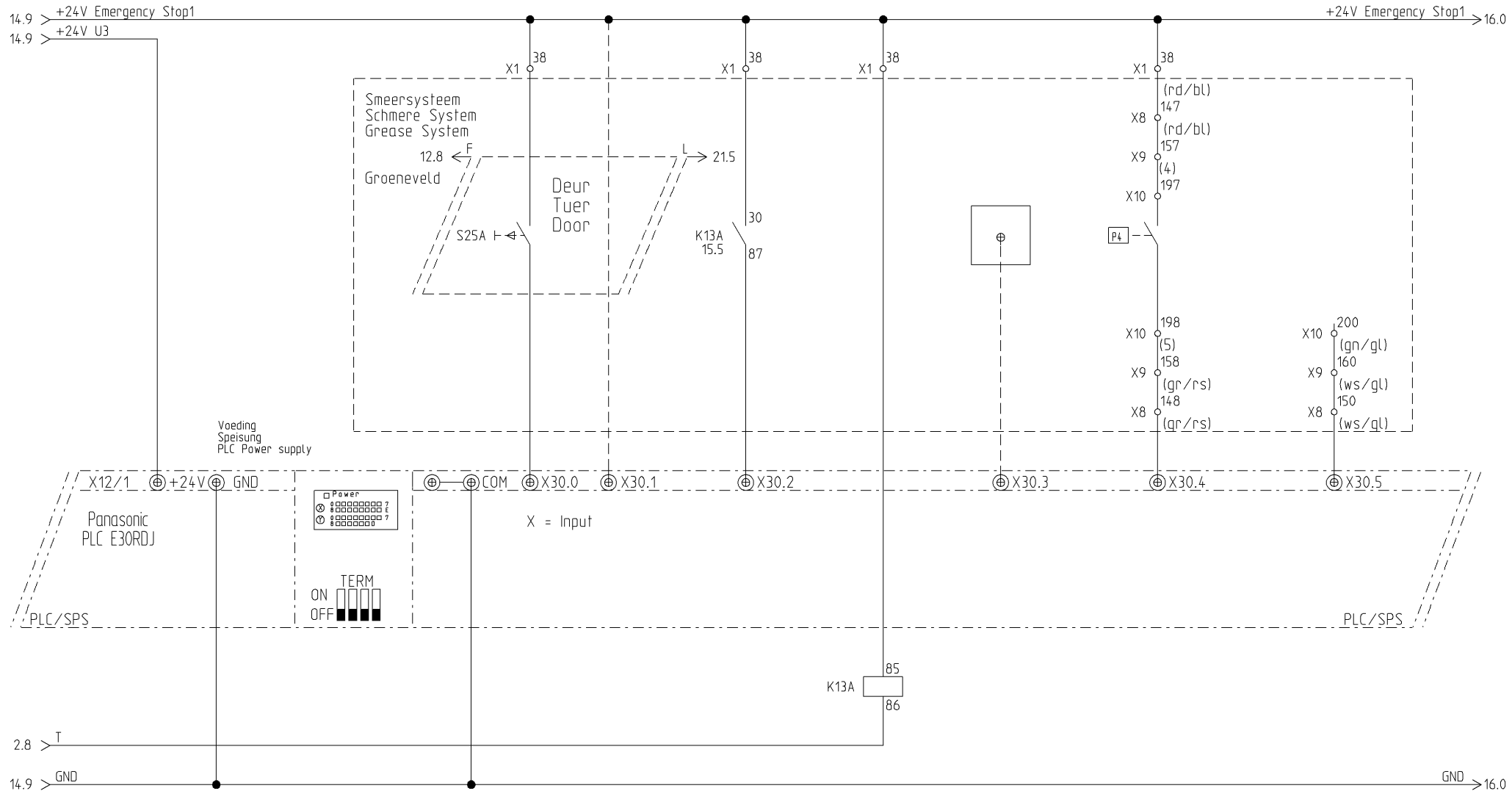

Start Overbr. Smeersyst. / Start Ueberbr. Schmere Syst. / Start Jumper Grease Syst.
 Vlottier / Schwimmshalter / Fladft Switch
 Hli Test Smeersyst. / Hli Test Schmere Syst. / Hli Test Grease Syst.
 Sensor laatste Smeerpoint / Sensor letzter Schmierpunkt / Sensor Last Grease Point
 Reserve / Reserve / Spare

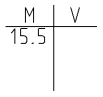

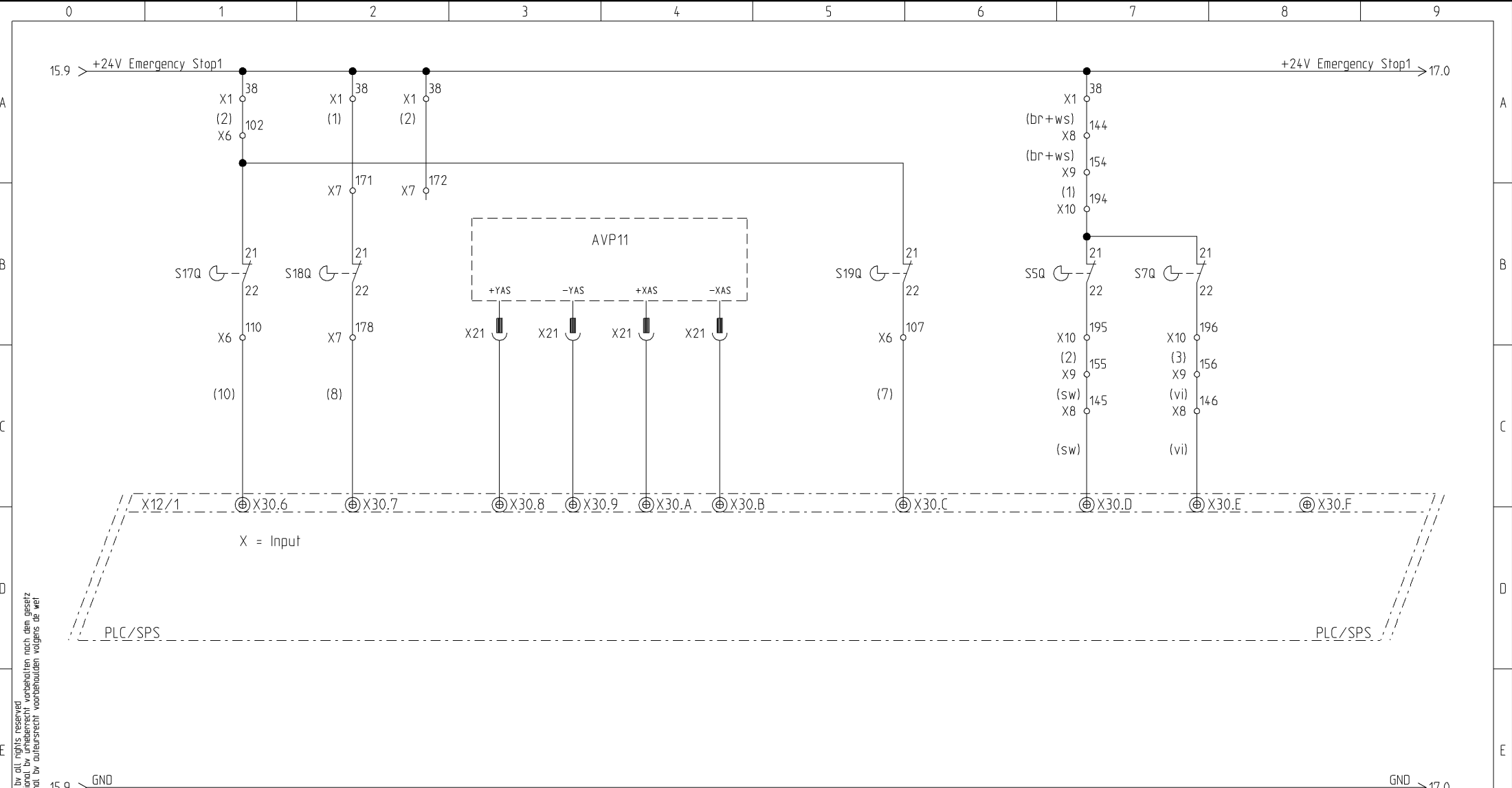

Vooras - Horizontaal - Achteras
 Vorn - Achse Hor. - Hinten
 Front - Axle Hor. - Rear

Autom. Waterpas
 Autom. Horizontal
 Autom. Level

Stempels Afslag 6mtr.
 Ausschaltung Stuetzen 6mtr.
 Cut-Out Jacks 6mtr.

Plattform in
 Plattform in

Overload
 Ueberlastung
 Overload

Reserve
 Reserve
 Spare

this drawing is property of Holland Lift International, by all rights reserved.
 diese zeichnung ist eigentum von Holland Lift International, by all rights reserved.
 deze tekening is eigendom van Holland Lift International, by auteursrecht voorbehouden volgens de wet



Holland Lift International B.V.
 Anodeweg 1
 NL-1627 LJ Hoorn The Netherlands
 T/F +31 (0)229-285555 / 285550
 E service@hollandlift.com
 W www.hollandlift.com

SPS Input
 X30.6 - X30.F

Projekt: EG-20-001	Zeichnungsnummer:	Rev.: A	erstellt von: Rothenbusch
Datum: 28.06.2013	Anlage: =	Ort: +	Blatt: 16

this drawing is property of Holland Lift International, by all rights reserved
 deze tekening is eigendom van Holland Lift International, by auteursrecht voorbehouden volgens de wet

16.9 > +24V Emergency Stop1 +24V Emergency Stop1 > 21.0

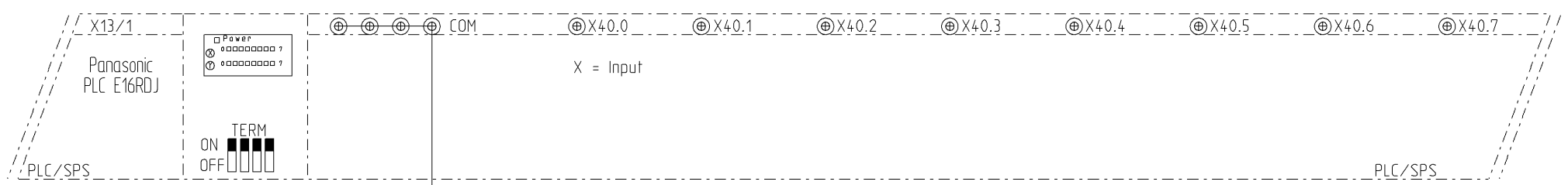

16.9 > GND GND > 18.0

Reserve Spare Reserve Spare Reserve Spare Reserve Spare Reserve Spare Reserve Spare Reserve Spare Reserve Spare Reserve Spare Reserve Spare



Holland Lift International B.V.
 Anodeweg 1
 NL-1627 LJ Hoorn The Netherlands
 T/F +31 (0)229-285555 / 285550
 E service@hollandlift.com
 W www.hollandlift.com

SPS Input
 X40.0 - X40.7

Projekt:	EG-20-001	Zeichnungsnummer:	Rev.:	A	erstellt von:	Rothenbusch	
Datum:	28.06.2013	Antage:	=	Ort:	+	Blatt:	17

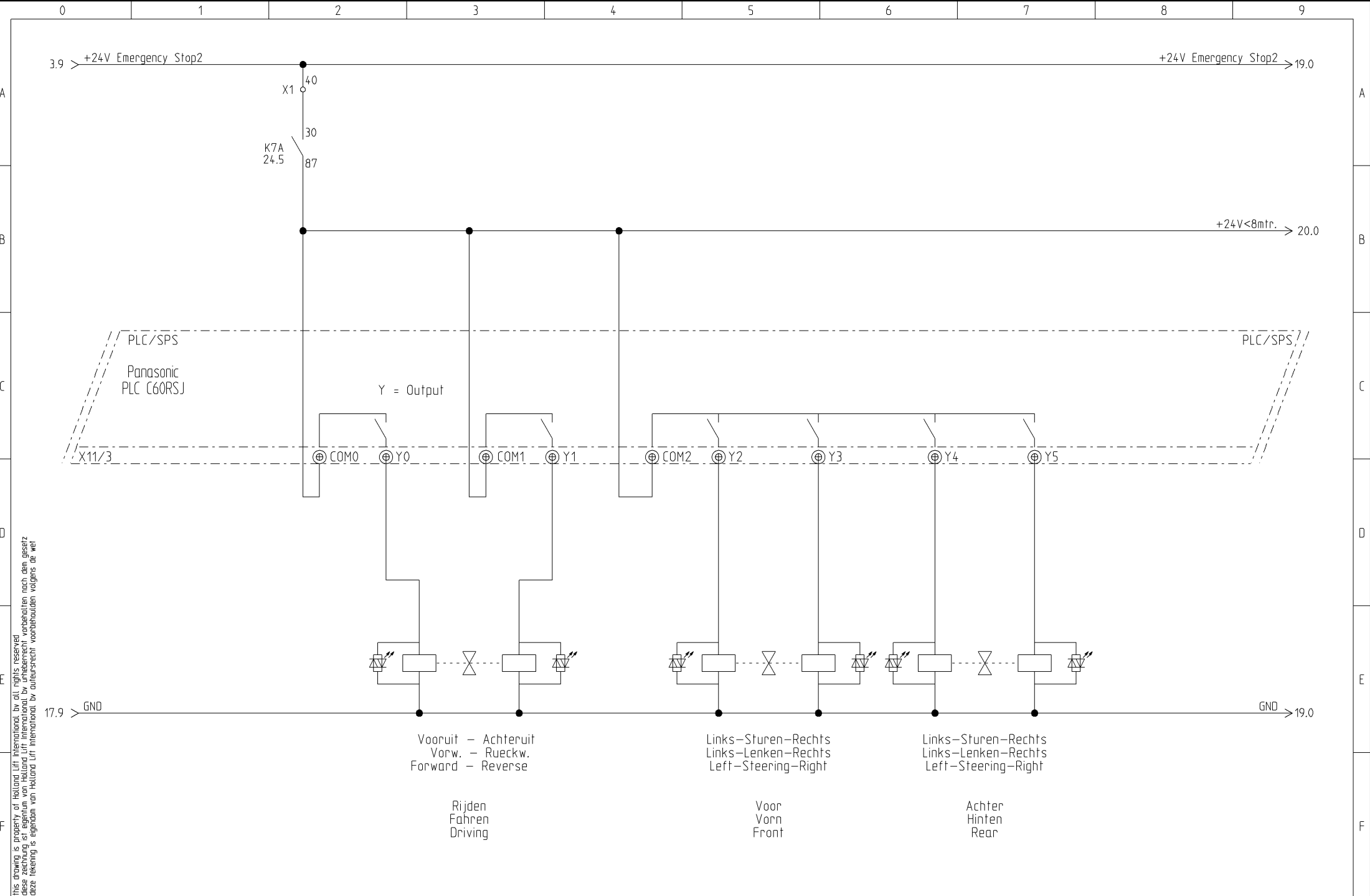

this drawing is property of Holland Lift International, by all rights reserved.
 deze tekening is eigendom van Holland Lift International, by auteursrecht voorbehouden volgens de wet.
 this drawing is property of Holland Lift International, by all rights reserved.
 deze tekening is eigendom van Holland Lift International, by auteursrecht voorbehouden volgens de wet.



Holland Lift International B.V.
 Anodeweg 1
 NL-1627 LJ Hoorn The Netherlands
 T/F +31 (0)229-285555 / 285550
 E service@hollandlift.com
 W www.hollandlift.com

SPS Output
 Y0 - Y5

Projekt: EG-20-001
 Datum: 28.06.2013

Zeichnungsnummer:
 Anlage: =

Rev.: A
 Ort: +

erstellt von: Rothenbusch
 Blatt: 18

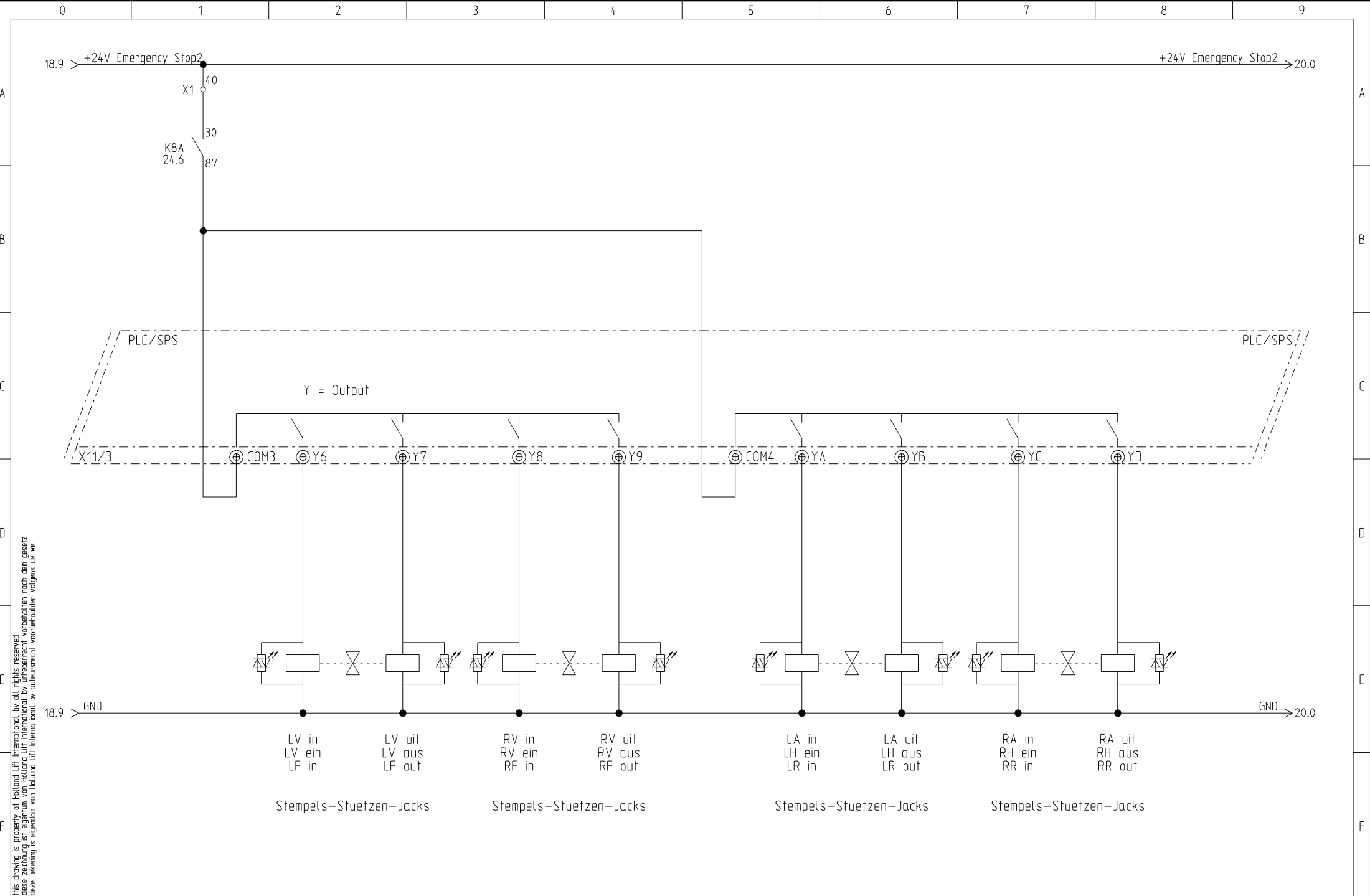

this drawing is property of Holland Lift International, by all rights reserved.
 deze tekening is eigendom van Holland Lift International, by auteursrecht voorbehouden volgens de wet.
 deze tekening is eigendom van Holland Lift International, by auteursrecht voorbehouden volgens de wet.



Holland Lift International B.V.
 Anodeweg 1
 NL-1627 LJ Hoorn The Netherlands
 T/F +31 (0)229-285555 / 285550
 E service@hollandlift.com
 W www.hollandlift.com

SPS Output
 Y6 - YD

Projekt: EG-20-001
 Datum: 28.06.2013

Zeichnungsnummer:
 Anlage: =

Rev.: A
 Ort: +

erstellt von: Rothenbusch
 Blatt: 19

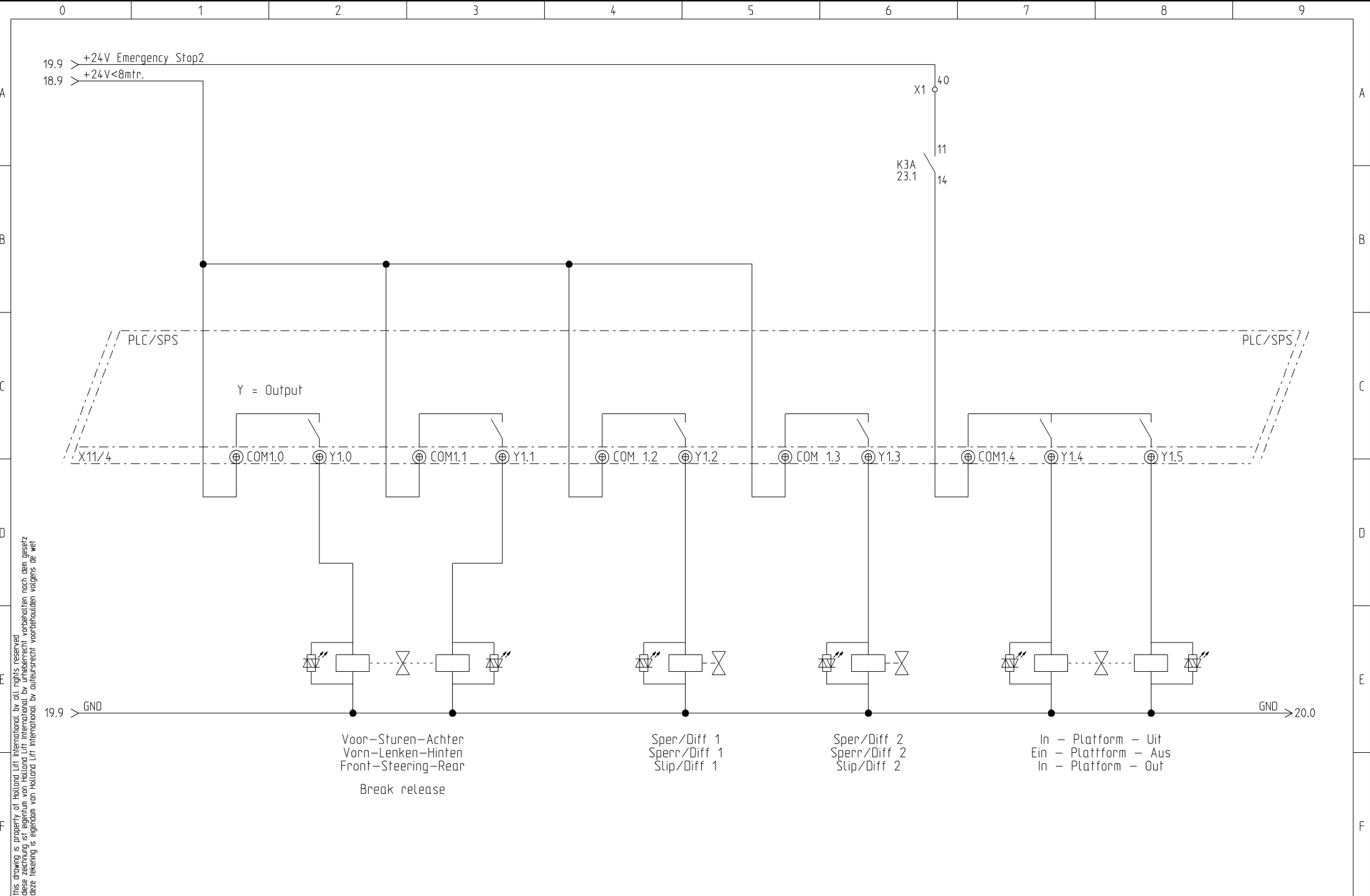

this drawing is property of Holland Lift International, by all rights reserved
 diese zeichnung ist eigentum von Holland Lift International, by urheberrecht vorbehalten nach dem gesetz
 deze tekening is eigendom van Holland Lift International, by auteursrecht voorbehouden volgens de wet



Holland Lift International B.V.
 Anodeweg 1
 NL-1627 LJ Hoorn The Netherlands
 T/F +31 (0)229-285555 / 285550
 E service@hollandlift.com
 W www.hollandlift.com

SPS Output
 Y1.0 - Y1.5

Projekt:	EG-20-001	Zeichnungsnummer:	Rev.:	A	erstellt von:	Rothenbusch
Datum:	28.06.2013	Anlage:	Ort:	=	Blatt:	20

this drawing is property of Holland Lift International, by all rights reserved.
 deze tekening is eigendom van Holland Lift International, by all rights reserved.
 deze tekening is eigendom van Holland Lift International, by all rights reserved.

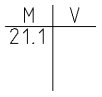
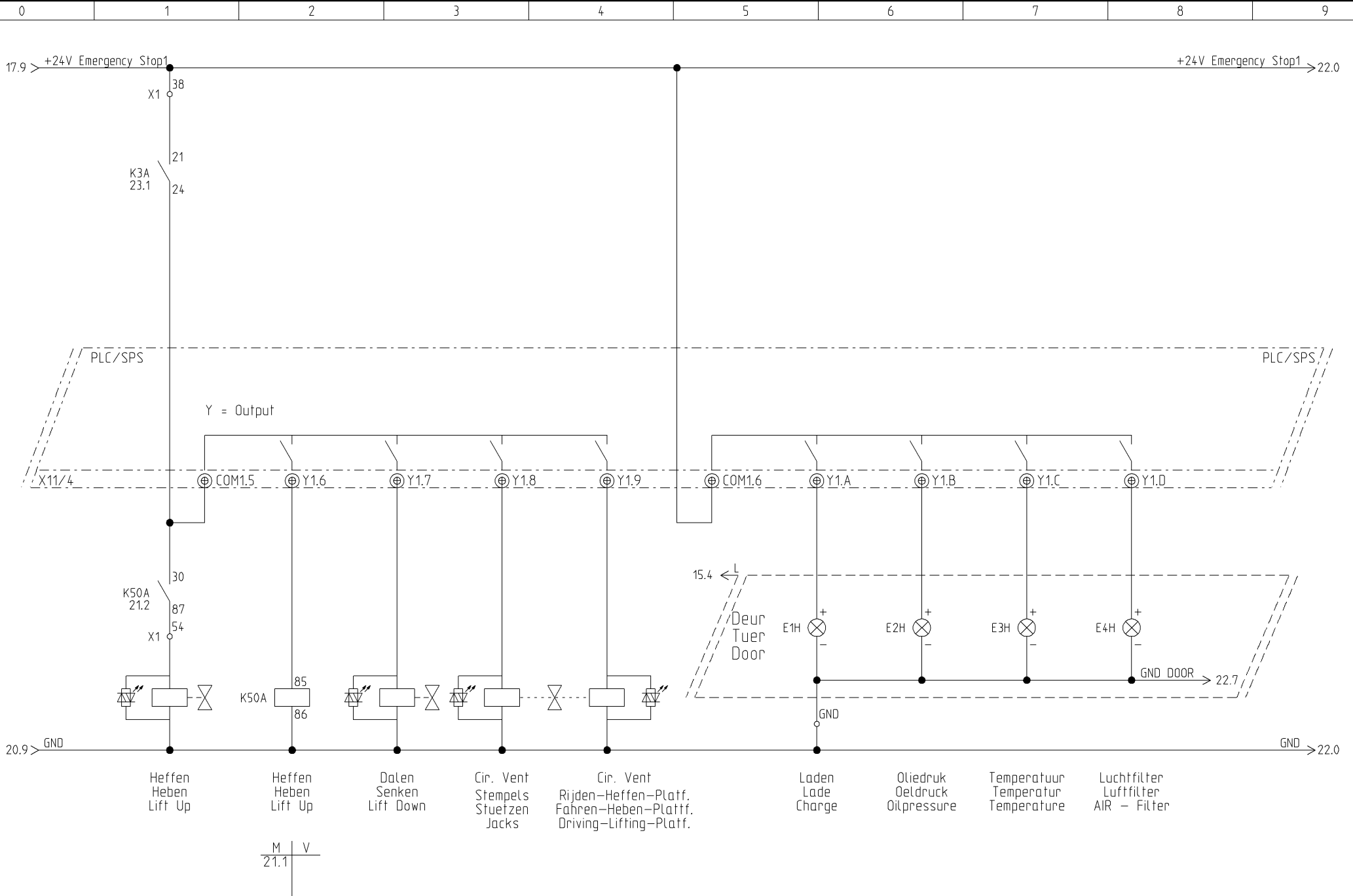

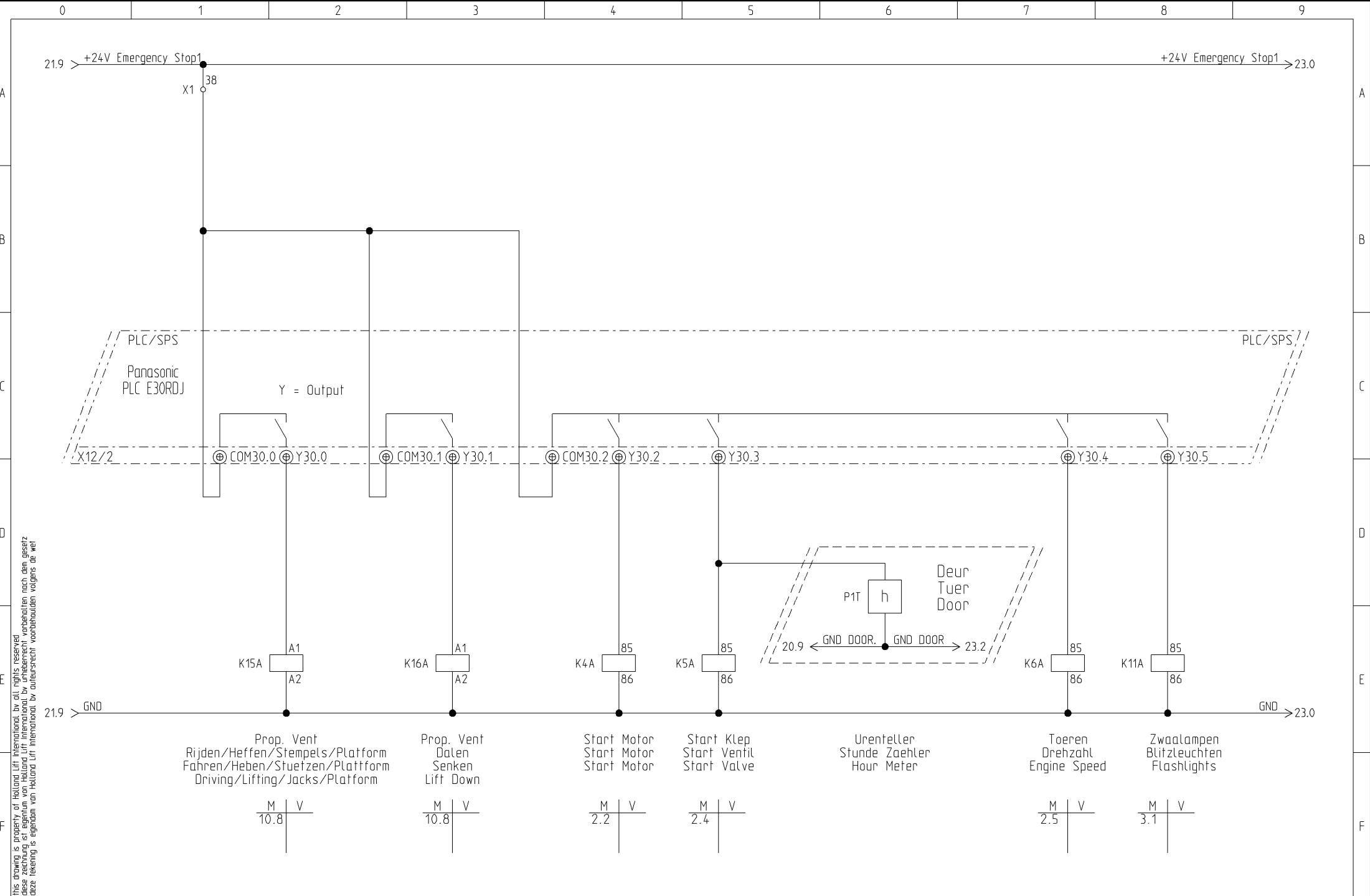

this drawing is property of Holland Lift International. By all rights reserved.
 deze tekening is eigendom van Holland Lift International. By auteursrecht voorbehouden volgens de wet.
 deze tekening is eigendom van Holland Lift International. By auteursrecht voorbehouden volgens de wet.

This drawing is property of Holland Lift International. By all rights reserved.
 deze tekening is eigendom van Holland Lift International. By auteursrecht voorbehouden volgens de wet

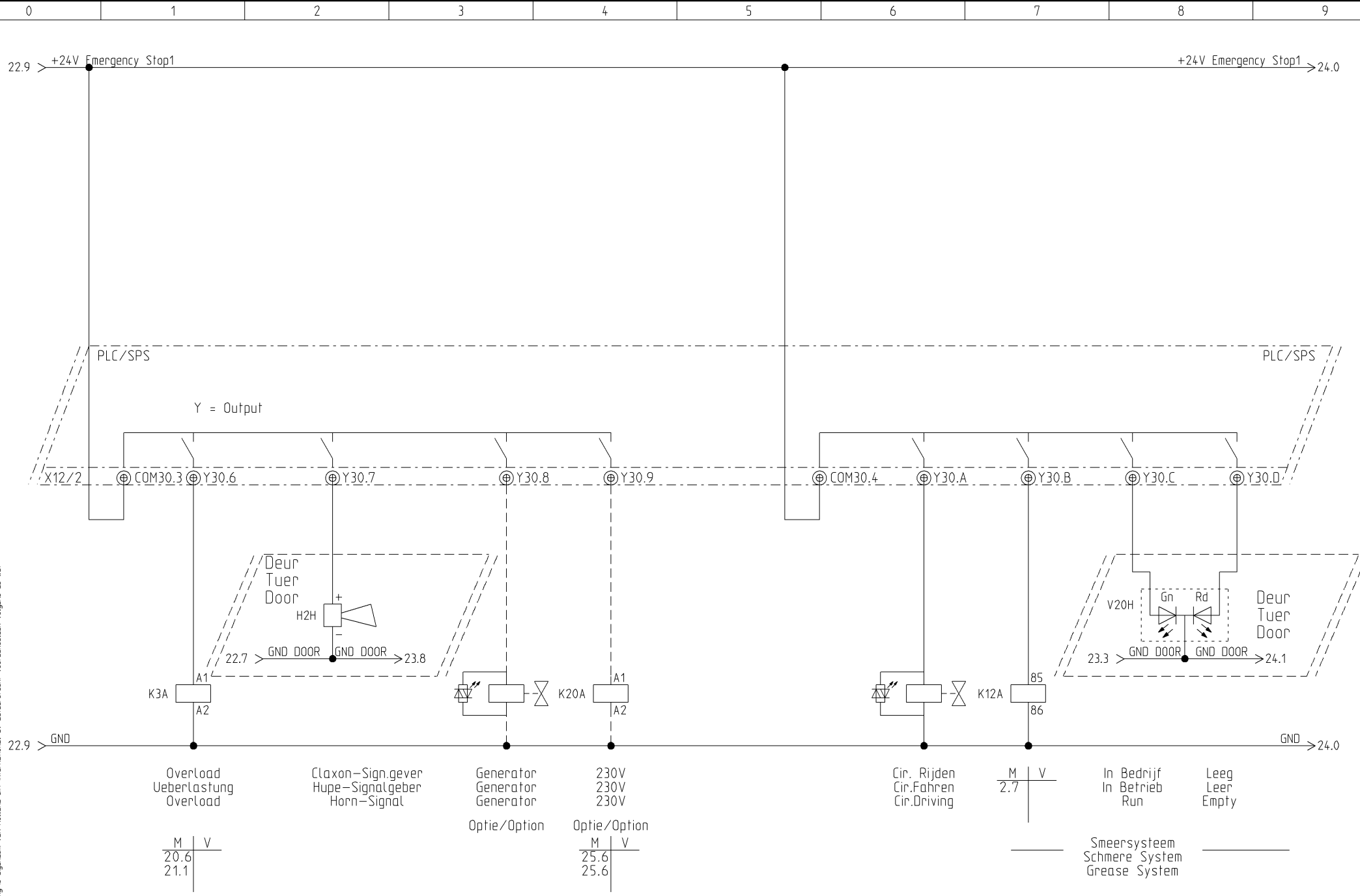

Holland Lift International B.V.
 Anodeweg 1
 NL-1627 LJ Hoorn The Netherlands
 T/F +31 (0)229-285555 / 285550
 E service@hollandlift.com
 W www.hollandlift.com

SPS-Output
 Y30.6 - Y30.D

Projekt:	EG-20-001	Zeichnungsnummer:	Rev.:	A	erstellt von:	Rothenbusch
Datum:	28.06.2013	Anlage:	Ort:	=	Blatt:	23

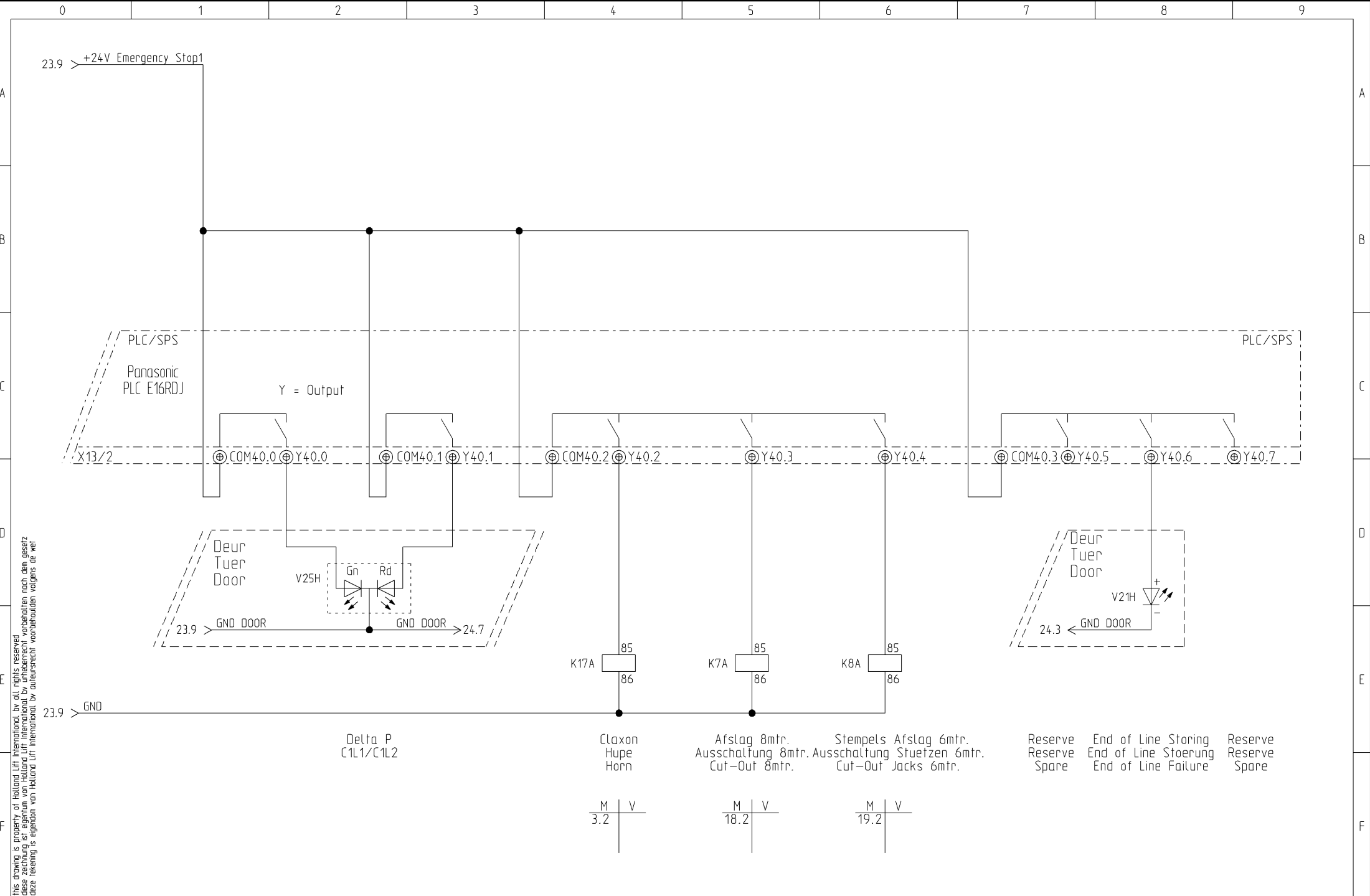

this drawing is property of Holland Lift International. By all rights reserved.
 deze tekening is eigendom van Holland Lift International. By all rights reserved.
 deze tekening is eigendom van Holland Lift International. By all rights reserved.

OPTIES
OPTIONEN
OPTIONS

230V AANSLUITING PLATFORM
230V ANSCHLUSS PLATTFORM
230V SUPPLY PLATFORM

<230VPLF>

230V-50Hz/115V-50Hz

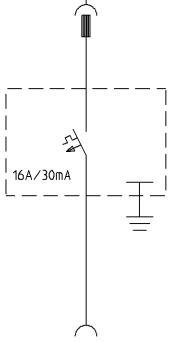

AARDLEKAUTOMAAT
FI SCHALTER
EARTH DETECTOR

230V AANSLUITING PLATFORM
230V ANSCHLUSS PLATTFORM
230V SUPPLY PLATFORM

<230V-GEN>

230V-50Hz/115V-50Hz

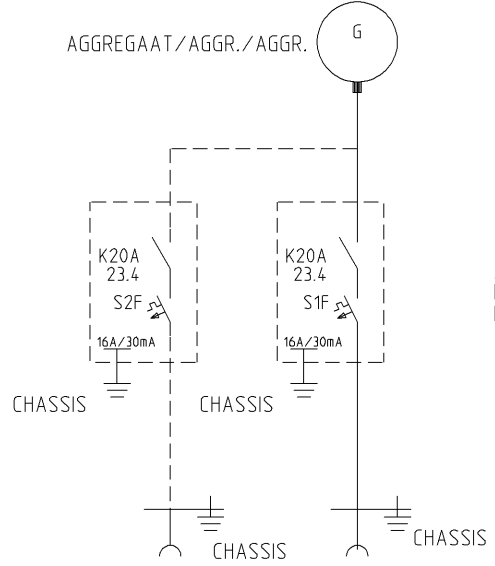

AARDLEKAUTOMAAT
FI SCHALTER
EARTH DETECTOR

this drawing is property of Holland Lift International, by all rights reserved
 deze tekening is eigendom van Holland Lift International, by auteursrecht voorbehouden volgens de wet
 deze tekening is eigendom van Holland Lift International, by auteursrecht voorbehouden volgens de wet



Holland Lift International B.V.
Anodeweg 1
NL-1627 LJ Hoorn The Netherlands
T/F +31 (0)229-285555 / 285550
E service@hollandlift.com
W www.hollandlift.com

Optionen

Projekt:	EG-20-001	Zeichnungsnummer:	Rev.:	A	erstellt von:	Rothenbusch	
Datum:	28.06.2013	Anlage:	=	Ort:	+	Blatt:	25

KLEMMENKAST KLEMMENKASTEN CONNECTION BOX

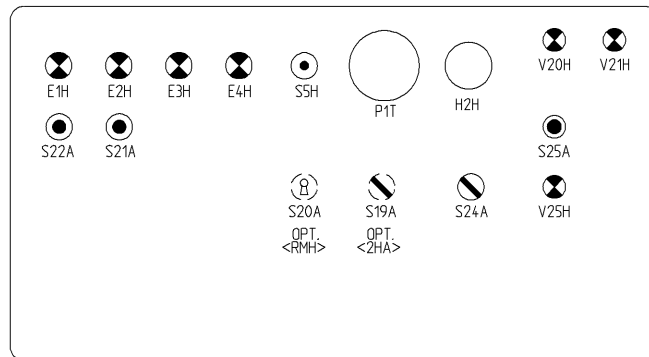
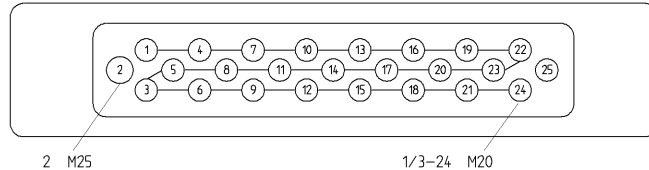
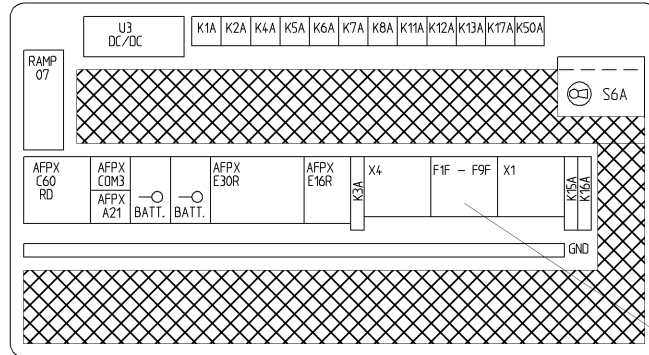

Colour schedule			
Colour	Dutch	English	Deutsch
Rd	Rood	Red	Rot
Bl	Blauw	Blue	Blau
Gl	Geel	Yellow	Gelb
Gn	Groen	Green	Grün
Zw	Zwart	Black	Schwarz
Wt	Wit	White	Weiss
Bn	Bruin	Brown	Braun
Rs	Roze	Pink	Rosa
Or	Oranje	Orange	Orange
Ps	Paars	Violet	Violett
Tp	Transp.	Transp.	Transp.
Gs	Grijs	Grey	Grau

ANSluiting OP Platform
ANSchluss AUf Plattform
CONNECTION ON Platform

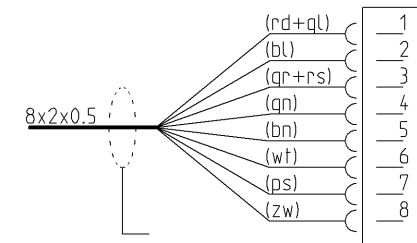

Afscherming niet aansluiten
(aftapen)

this drawing is property of Holland Lift International, by all rights reserved
diese zeichnung ist eigentum von Holland Lift International, by urheberrecht vorbehalten nach dem gesetz
deze tekening is eigendom van Holland Lift International, by auteursrecht voorbehouden volgens de wet

HOLLAND LIFT

Holland Lift International B.V.
Anodeweg 1
NL-1627 LJ Hoorn The Netherlands
T/F +31 (0)229-285555 / 285550
E service@hollandlift.com
W www.hollandlift.com

Kasten/Bekabelung
Kasten/Bekabelung
Boxes/Cables

Projekt:
EG-20-001

Zeichnungsnummer:

Rev.:
A

erstellt von:
Rothenbusch

Datum:
28.06.2013

Antage:
=

Ort:
+

Blatt:
26

KLEMMENKAST KLEMMENKASTEN CONNECTION BOX

WARTEL KABELEINF. GLAND NR.	KLEM KLEMMEN TERMINAL NR	FUNKTIE	FUNKTION	FUNCTION
1	DIV/VAR	Aanstl. 10P Platform	Anschl. 10P Plattform	Conn. 10P Platform
2	DIV/VAR	Lasdoos voor	Verteilerdose vorn	Connection Box front
3	DIV/VAR	Lasd. Cyl1/ Cyl2/Plf	Vert. Cyl1/ Cyl2/Plf	Conn. Cyl1/ Cyl2/Plf
4	DIV/VAR	Smeersytem	Schmiere System	Grease System
5.1	Y0-GND	Rijden Vooruit	Fahren Vorwaerts	Driving Forward
5.2	Y1-GND	Rijden Achteruit	Fahren Rueckwaerts	Driving Reverse
6.1	Y2-GND	Sturen Links Voor	Lenken Links Vorn	Steering Left Front
6.2	Y3-GND	Sturen Rechts Voor	Lenken Rechts Vorn	Steering Right Front
7.1	Y4-GND	Sturen Links Achter	Lenken Links Hinten	Steering Left Rear
7.2	Y5-GND	Sturen Rechts Achter	Lenken Rechts Hinten	Steering Right Rear
8.1	Y1.0-GND	Ontlast. Sturen Voor	Entlast. Lenken Vorn	Reliese Steering Front
8.2	Y1.1-GND	Ontlast. Sturen Achter	Entlast. Lenken Hinten	Reliese Steering Rear
9.1	Y1.2-GND	Sper/Diff. Ventiel	Sperr/Diff. Ventil	Slip/Diff. Valve
9.2	Y1.3-GND	Sper/Diff. Ventiel	Sperr/Diff. Ventil	Slip/Diff. Valve
10.1	Y30.A-GND	Cir. Vent Ri.-He.-Pl.	Cir. Vent. Fa.-He.-Pl.	Cir. Valve Dr.-L.-Pl.
10.2	Y1.9-GND	Cir. Ventiel Rijden	Cir. Ventil Fahren	Cir. Valve Diving
11.1	Y1.8-GND	Cir. Ventiel Stempels	Cir. Ventil Stuetzen	Cir. Valve Jacks
11.2	DIV/VAR	Auto Niv.	Auto Niv.	Auto Niv.
12.1	φ 38-GND-X4	Scheefstand	Neigung	Inclination
12.2	φ 38-GND-X5	Scheefstand Opt.	Neigung Opt.	Inclination Opt.
13.1	φ 50-GND	Heffen	Heben	Lift Up
13.2	Y1.7-GND	Dalen	Senken	Lift Down
14.1	Y1.4-GND	Platform in	Plattform ein	Platform in
14.2	Y1.5-GND	Platform uit	Plattform aus	Platform out
15.1	Y6-GND	Stempels LV in	Stuetzen LV ein	Jacks LF in
15.2	Y7-GND	Stempels LV uit	Stuetzen LV aus	Jacks LF out
16.1	Y8-GND	Stempels RV in	Stuetzen RV ein	Jacks RF in
16.2	Y9-GND	Stempels RV uit	Stuetzen RV aus	Jacks RF out
17.1	YC-GND	Stempels RA in	Stuetzen RH ein	Jacks RR in
17.2	YD-GND	Stempels RA uit	Stuetzen RH aus	Jacks RR out
18.1	YA-GND	Stempels LA in	Stuetzen LH ein	Jacks LR in
18.2	YB-GND	Stempels LA uit	Stuetzen LH aus	Jacks LR out
19	DIV/VAR	Lasdoos achter	Verteilerdose hinten	Connection Box rear

WARTEL KABELEINF. GLAND NR.	KLEM KLEMMEN TERMINAL NR	FUNKTIE	FUNKTION	FUNCTION
20.1	φ 1	Voeding +24V	Speisung +24V	Power Supply +24V
20.2	GND	Voeding GND	Speisung GND	Power Supply GND
20.3	φ 23	+ Generator	+ Generator	+ Generator
21.1	φ 66	Claxon	Horn	Horn
21.2	Y30.9-GND	Relais Aggregaat Opt.	Relais Aggr. Opt.	Relais Aggr. Opt.
22.1	φ 39 -X1.4	Tank leeg	Tank leer	Tank empty
22.2	φ 68 -φ 67	Prop. Ventiel Dalen	Prop. Ventil Senken	Prop. Valve Lift Down
23.1	Y30.8-GND	Hydr. Aggregaat Opt.	Hydr. Aggr. Opt.	Hydr. Aggr. Opt.
23.2	DIV/VAR	RPM Teller Generator	RPM Zaehler Generator	RPM Meter Generator
24	Res./Spare	-	-	-
25	DIV/VAR	Diesel	Diesel	Diesel

this drawing is property of Holland Lift International, by all rights reserved.
 diese zeichnung ist eigentum von Holland Lift International, by alle rechte vorbehalten.
 deze tekening is eigendom van Holland Lift International, by auteursrecht voorbehouden volgens de wet

HOLLAND LIFT

Holland Lift International B.V.
 Anodeweg 1
 NL-1627 LJ Hoorn The Netherlands
 T/F +31 (0)229-285555 / 285550
 E service@hollandlift.com
 W www.hollandlift.com

Kasten/Bekabelung
 Kasten/Bekabelung
 Boxes/Cables

Projekt:
 EG-20-001

Zeichnungsnummer:

Rev.: A

erstellt von:
 Rothenbusch

Datum:
 28.06.2013

Anlage:
 =

Ort:
 +

Blatt:
 27

KLEMMENKAST KLEMMENKASTEN CONNECTION BOX

X4										X1																						
		2	4	5	7	6	3	6	4	6	5	6									31	32	33	38	38	38	39	39	40	54		
1	23																															
		14	17	3	18	6	7	6	8	6	9	7	0	F1F 20A	F2F 20A	F3F 5A	F4F 5A	F5F 5A	F6F 20A	F7F 7.5A	F8F 7.5A	F9F 7.5A										
1	23																															
		14	17	3	18	6	7	6	8	6	9	7	0																			
		2	4	5	7	6	3	6	4	6	5	6																				

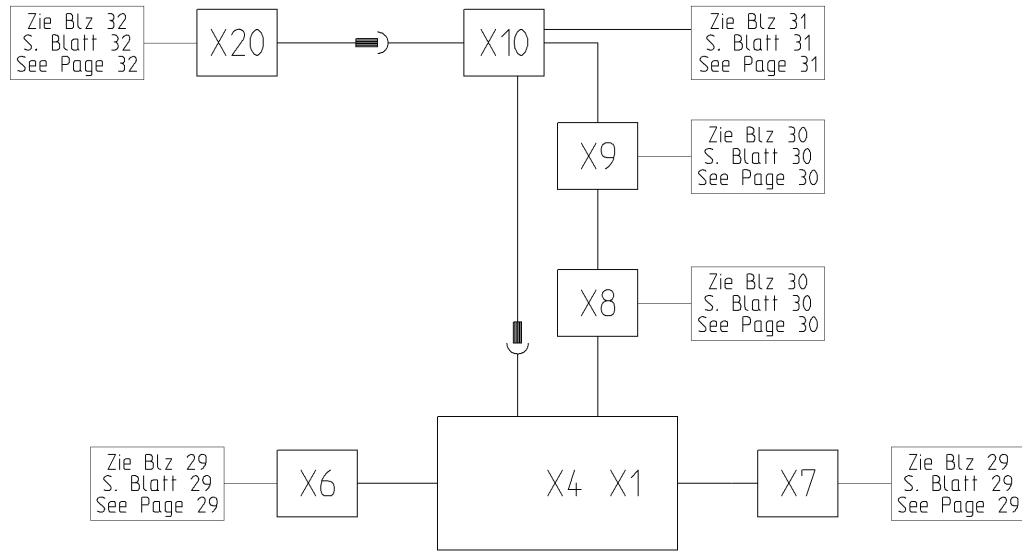

this drawing is property of Holland Lift International, by all rights reserved
 deze tekening is eigendom van Holland Lift International, by auteursrecht voorbehouden volgens de wet



Holland Lift International B.V.
 Anodeweg 1
 NL-1627 LJ Hoorn The Netherlands
 T/F +31 (0)229-285555 / 285550
 E service@hollandlift.com
 W www.hollandlift.com

Kasten/Bekabelung
 Kasten/Bekabelung
 Boxes/Cables

Projekt:	EG-20-001	Zeichnungsnummer:	Rev.:	A	erstellt von: Rothenbusch
Datum:	28.06.2013	Antage:	=	Ort:	+
					Blatt: 28

KAST CYLINDER LAAG (1)
 KASTEN ZYLINDER NIEDRIG (1)
 CYLINDER BOX LOW (1)

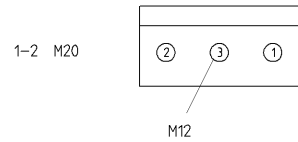
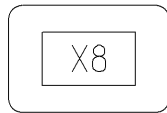

X8

	+	+					+			+				-
	141	141	142	143	AFS	AFS	144	145	146	147	148	149	150	

NR.	Omschrijving	Beschreibung	Description
1	Kabel Klemmenkast	Kabel Klemmenkasten	Cable Connection Box
2	Cyl. 2 hoog	Zyl. 2 hoch	Cly. 2 high
3	Druksensor Cyl. 1 (4-20mA)	Drucksensor Zyl. 1 (4-20mA)	Press. Sensor Cyl. 1 (4-20mA)

KAST CYLINDER HOOG (2)
 KASTEN ZYLINDER HOCH (2)
 CYLINDER BOX HIGH (2)

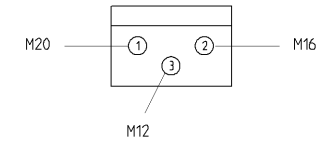
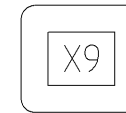
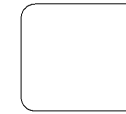

X9

	+			+			+			-
	151	153	AFS	154	155	156	157	158	159	160

NR.	Omschrijving	Beschreibung	Description
1	Cyl. 1 laag	Zyl. 1 niedrig	Cly. 1 low
2	Lasdoos Platform	Verteilerdose Plattform	Connection Box Platform
3	Druksensor Cyl. 2 (4-20mA)	Drucksensor Zyl. 2 (4-20mA)	Press. Sensor Cyl. 2 (4-20mA)

this drawing is property of Holland Lift International, by all rights reserved.
 diese zeichnung ist Eigentum von Holland Lift International, by alle rechte vorbehalten nach dem gesetz.
 deze tekening is eigendom van Holland Lift International, by auteursrecht voorbehouden volgens de wet

HOLLAND LIFT

Holland Lift International B.V.
 Anodeweg 1
 NL-1627 LJ Hoorn The Netherlands
 T/F +31 (0)229-285555 / 285550
 E service@hollandlift.com
 W www.hollandlift.com

Kasten/Bekabelung
 Kasten/Bekabelung
 Boxes/Cables

Projekt:	EG-20-001	Zeichnungsnummer:	Rev.:	A	erstellt von:	Rothenbusch	
Datum:	28.06.2013	Antage:	=	Ort:	+	Blatt:	30

LASDOOS PLATFORM
VERTEILERDOSE PLATFORM
PLATFORM DISTRBUOR BOX

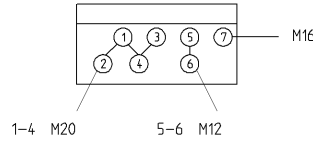
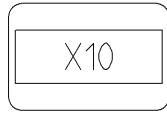

X10

+				-				+				-							
121	122	123	124	125	126	127	128	129	130	131	132	133	134	135	136	137	138	139	140

NR.	Omschrijving	Beschreibung	Description
1	Kabel Klemmenkast	Kabel Klemmenkasten	Cable Connection Box
2	Cyl. 2 hoog	Zyl. 2 hoch	Cyl. 2 high
3	WCD voor	Verteilerdose vorn	Connection Box front
4	WCD achter	Verteilerdose hinten	Connection Box rear
5	Eindschak. Platform in S5Q	Endschalter Plattform ein S5Q	Limit Switch Platform in S5Q
6	Eindschak. Overload S7Q	Endschalter Ueberlast S7Q	Limit Switch Overload S7Q
7	Drukschak. Smeersyst. (Opt.)	Druckschalt. Schmiersyst. (Opt.)	Press. Swit. Grease Syst. (Opt.)

MOTOR KABEL (SLANG)
MOTOR KABEL (SCHLAUCH)
MOTOR CABLE (TUBE)

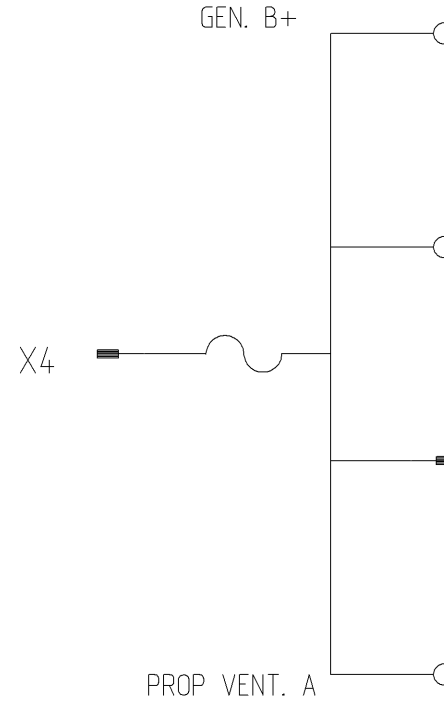

X4 NR.	Draad	Kleur	Plug 1P	Contact Nr.
23	1x6	rd	Female	1

X4 NR.	Draad	Kleur	Plug 1P	Contact Nr.
2	1x1	zw	Female	2
3	1x1.5	zw	Female	3
4	1x1	zw	Female	4
7	1x1.5	zw	Female	5
22	1x1	zw	Female	6

X4 NR.	Draad	Kleur	Plug 1P	Contact Nr.
5	1x1	zw	Male	5
14	1x1.5	zw	Male	2
17	1x1	zw	Male	3
18	1x1.5	zw	Male	4
RES.	1x1.5	zw	Male	

X4 NR.	Draad	Kleur	Plug 1P	Contact Nr.
69	2x1.5	-	-	1
70		-	-	2

this drawing is property of Holland Lift International, by all rights reserved
 deze tekening is eigendom van Holland Lift International, by auteursrecht voorbehouden volgens de wet
 diese zeichnung ist Eigentum von Holland Lift International, by Urheberrecht vorbehalten nach dem Gesetz



Holland Lift International B.V.
 Anodeweg 1
 NL-1627 LJ Hoorn The Netherlands
 T/F +31 (0)229-285555 / 285550
 E service@hollandlift.com
 W www.hollandlift.com

Kasten/Bekabelung
 Kasten/Bekabelung
 Boxes/Cables

Projekt: EG-20-001

Zeichnungsnummer:

Rev.: A

erstellt von: Rothenbusch

Datum: 28.06.2013

Antage:

Ort: +

Blatt: 31

BEDIENINGSKAST STEUERPULT CONTROL BOX

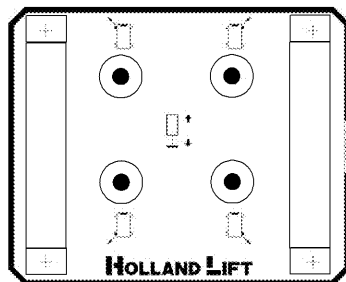
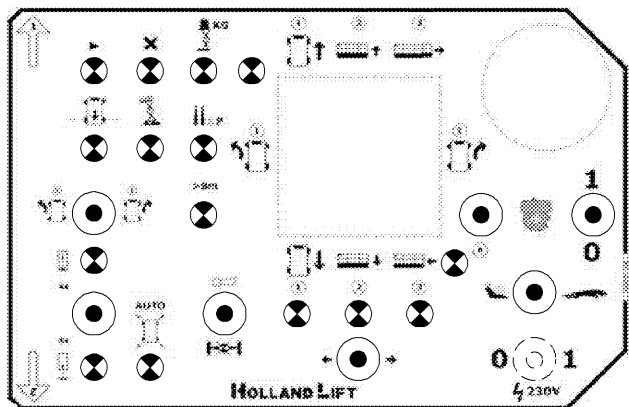

Colour schedule			
Colour	Dutch	English	Deutsch
Rd	Rood	Red	Rot
Bl	Blauw	Blue	Blau
Gl	Geel	Yellow	Gelb
Gn	Groen	Green	Gruen
Zw	Zwart	Black	Schwarz
Wt	Wit	White	Weiss
Bn	Bruin	Brown	Braun
Rs	Roze	Pink	Rosa
Or	Oranje	Orange	Orange
Ps	Paars	Violet	Violett
Tp	Transp.	Transp.	Transp.
Gs	Grijs	Grey	Grau

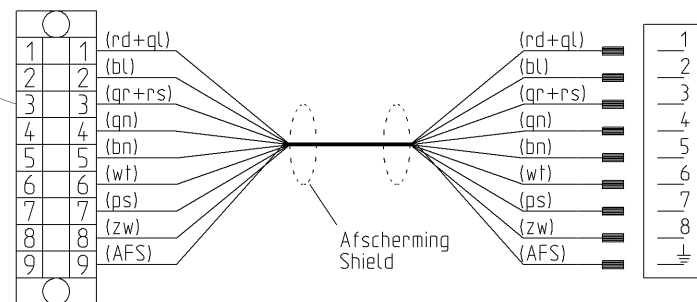
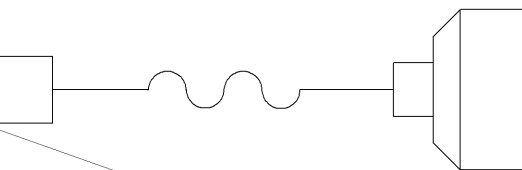
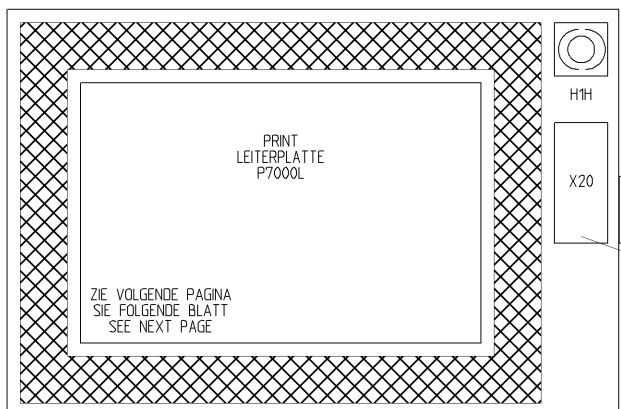

this drawing is property of Holland Lift International, by all rights reserved.
 deze tekening is eigendom van Holland Lift International, by auteursrecht voorbehouden volgens de wet.
 deze tekening is eigendom van Holland Lift International, by auteursrecht voorbehouden volgens de wet.

HOLLAND LIFT

Holland Lift International B.V.
 Anodeweg 1
 NL-1627 LJ Hoorn The Netherlands
 T/F +31 (0)229-285555 / 285550
 E service@hollandlift.com
 W www.hollandlift.com

Kasten/Bekabelung
 Kasten/Bekabelung
 Boxes/Cables

Projekt: EG-20-001

Zeichnungsnummer:

Rev.: A

erstellt von:
 Rothenbusch

Datum: 28.06.2013

Anlage: =

Ort: +

Blatt: 32

PRINTPLAAT
LEITERPLATTE
CIRCUIT BOARD

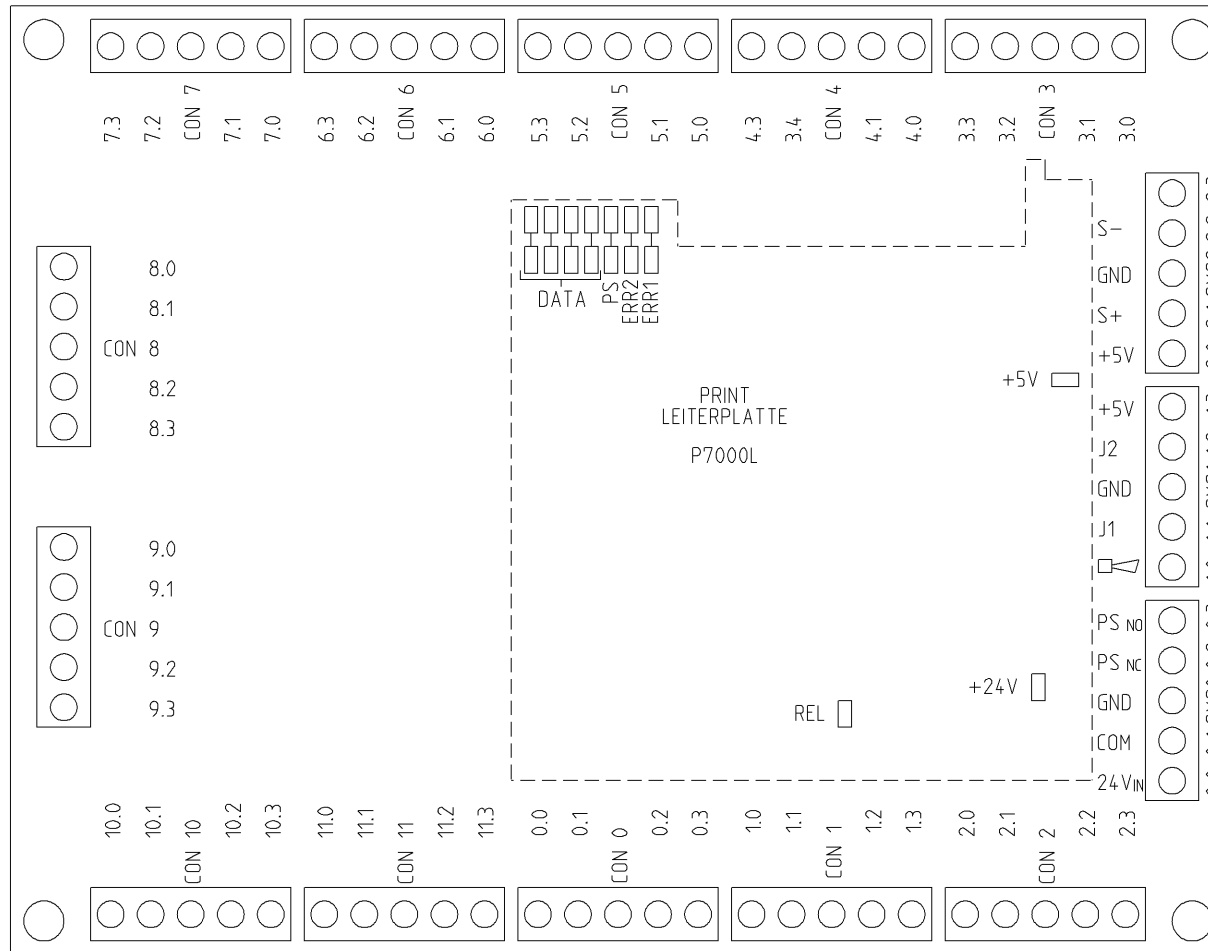

+24V	<input type="checkbox"/>	Groen/Gruen/Green	Voeding Ok	Speisung Ok	Supply Ok
+5V	<input type="checkbox"/>	Groen/Gruen/Green	Voeding Ok	Speisung Ok	Supply Ok
REL	<input type="checkbox"/>	Groen/Gruen/Green	Power Safe aan	Power Safe an	Power Safe on
PS	<input type="checkbox"/>	Geel/Gelb/Yellow	Power Safe uit	Power Safe aus	Power Safe off
Err1	<input type="checkbox"/>	Geel/Gelb/Yellow	Slechte Data Verbinding	Schlechte Data Verbindung	Poor Data Connection
Err2	<input type="checkbox"/>	Rood/Rot/Red	Geen Data Verbinding	Keine Data Verbindung	No Data Connection

this drawing is property of Holland Lift International, by all rights reserved.
 diese zeichnung ist eigentum von Holland Lift International, by urheberrecht vorbehalten nach dem gesetz.
 deze tekening is eigendom van Holland Lift International, by auteursrecht voorbehouden volgens de wet.

HOLLAND LIFT

Holland Lift International B.V.
 Anodeweg 1
 NL-1627 LJ Hoorn The Netherlands
 T/F +31 (0)229-285555 / 285550
 E service@hollandlift.com
 W www.hollandlift.com

Printplaat
 Leiterplatte
 Circuit Board

Projekt:
EG-20-001

Zeichnungsnummer:

Rev.: A

erstellt von:
Rothenbusch

Datum:
28.06.2013

Anlage:
=

Ort:
+

Blatt:
33

0.0	Rijden Vooruit (S1A2)	Fahren Vorwaerts (S1A2)	Driving Forward (S1A2)
0.1	Rijden Achteruit (S1A3)	Fahren Rueck. (S1A3)	Driving Reverse (S1A3)
CON 0			
0.2	Sturen Links (S1A4)	Lenken Links (S1A4)	Steering Left (S1A4)
0.3	Sturen Rechts (S1A5)	Lenken Rechts (S1A5)	Steering Right (S1A5)

1.0	Claxon (S2A1)	Hupe (S2A1)	Horn (S2A1)
1.1	Sper/Diff. (S2A2)	Sperr/Diff. (S2A2)	Slip/Diff. (S2A2)
CON 1			
1.2	Hef./Rij./Pla. (S3A1)	Heb./Fah./Pla. (S3A1)	Lif./Dri./Pla. (S3A1)
1.3	Hef./Rij./Pla. (S3A2)	Heb./Fah./Pla. (S3A2)	Lif./Dri./Pla. (S3A2)

2.0	Snel Rijden (S4A1)	Schnell Fahren (S3A1)	Driving Fast (S3A1)
2.1	Toerental (S9A)	Drehzahl (S9A)	Enging Speed (S9A)
CON 2			
2.2	Langzaam Rij. (S4A2)	Langsam Fahren (S4A2)	Driving Slow (S4A1)
2.3	Dodemansknop (S1A1)	Totmanskноп (S1A1)	Dead Man (S1A1)

0.0	Voeding +24V (S1M)	Speisung +24V (S1M)	Supply +24V (S1M)
0.1	Voeding +24V (S1M)	Speisung +24V (S1M)	Supply +24V (S1M)
SYS0 GND	GND	GND	GND
0.2	Reserve	Reserve	Spare
0.3	Voeding +24V (PS)	Speisung +24V (PS)	Supply +24V (PS)

1.0	+ Zoemer (H1H)	+ Summer (H1H)	+ Buzzer (H1H)
1.1	0-5V Joystick P1	0-5V Joystick P1	0-5V Joystick P1
SYS1 GND	- Zoemer (H1H)	- Summer (H1H)	- Buzzer (H1H)
1.2	Reserve (0-5V)	Reserve (0-5V)	Spare (0-5V)
1.3	Voeding +5V Joy. (P1)	Speisung +5V Joy. (P1)	Supply +5V Joy. (P1)

2.0	Reserve (+5V)	Reserve (+5V)	Spare (+5V)
2.1	Data S+ (RS485)	Data S+ (RS485)	Data S+ (RS485)
SYS2 GND	Reserve	Reserve	Spare
2.2	Data S- (RS485)	Data S- (RS485)	Data S- (RS485)
2.3	Reserve	Reserve	Spare

3.0	Sturen LA (S10A1)	Lenken LH (S10A1)	Steering LR (S10A1)
3.1	Sturen RA (S10A2)	Lenken RH (S10A2)	Steering RR (S10A2)
CON 3			
3.2	4x Stempels in (S7A1)	4x Stuetzen ein (S7A1)	4x Jacks in (S7A1)
3.3	4x uit Au. Niv. (S7A2)	4x aus Au. Niv. (S7A2)	4x out Au. Niv. (S7A2)

4.0	Reserve	Reserve	Spare
4.1	Reserve	Reserve	Spare
CON 4			
4.2	Reserve	Reserve	Spare
4.3	Reserve	Reserve	Spare

5.0	Vetpomp (V7H)	Fett Pumpe (V7H)	Grease Pump (V7H)
5.1	Overload (V1H)	Ueberspannung (V1H)	Overload (V1H)
CON 5			
5.2	Scheefstand (V2H)	Neigung (V2H)	Inclination (V2H)
5.3	Tank leeg (V8H) Opt.	Tank leer (V8H) Opt.	Tank empty (V8H) Opt.

6.0	Start Motor (S11A1)	Start Motor (S11A1)	Start Engine (S11A1)
6.1	Stop Motor (S11A2)	Halte Motor (S11A2)	Stop Engine (S11A2)
CON 6			
6.2	Gen. aan Opt. (S18A1)	Gen. an Opt. (S18A1)	Gen. on Opt. (S18A1)
6.3	Gen. uit Opt. (S18A2)	Gen. aus Opt. (S18A2)	Gen. off Opt. (S18A2)

7.0	Stempels LA in (S15A1)	Stuetzen LH ein (S15A1)	Jacks LR in (S15A1)
7.1	Stemp. LA uit (S15A2)	Stuetzen LH aus (S15A2)	Jacks LR out (S15A2)
CON 7			
7.2	Stempels RA in (S16A1)	Stuetzen RH ein (S16A1)	Jacks RR in (S16A1)
7.3	Stemp. RA uit (S16A2)	Stuetzen RH aus (S16A2)	Jacks RR out (S16A2)

8.0	Stempels LV in (S13A1)	Stuetzen LV ein (S13A1)	Jacks LF in (S13A1)
8.1	Stemp. LV uit (S13A2)	Stuetzen LV aus (S13A2)	Jacks LF out (S13A2)
CON 8			
8.2	Stempels RV in (S14A1)	Stuetzen RV ein (S14A1)	Jacks RF in (S14A1)
8.3	Stemp. RV uit (S14A2)	Stuetzen RV aus (S14A2)	Jacks RF out (S14A2)

9.0	8mtr. Afslag (V15H)	8mtr. Ausschalt. (V15H)	8mtr. Cut-out (V15H)
9.1	Stempels in (V11H)	Stuetzen ein (V11H)	Jacks in (V11H)
CON 9			
9.2	Stempels uit (V5H)	Stuetzen aus (V5H)	Jacks out (V5H)
9.3	Auto Niv. (V9H)	Auto Niv. (V9H)	Auto Niv. (V9H)

10.0	In Bedrijf (V10H)	In Betrieb (V10H)	Run (V10H)
10.1	Storing Dieselm. (V3H)	Stoerung Dieselm. (V3H)	Failure Dieselm. (V3H)
CON 10			
10.2	Vooras Recht (V4H)	Vorn Achse Hor. (V4H)	Axle front Hor. (V4H)
10.3	Platform uit (V6H)	Platform aus (V6H)	Platform out (V6H)

11.0	Heffen (V12H)	Heben (V12H)	Lifting (V12H)
11.1	Rijden (V13H)	Fahren (V13H)	Driving (V13H)
CON 11			
11.2	Platform (V14H)	Plattform (V14H)	Platform (V14H)
11.3	Delta P (V16H)	Delta P (V16H)	Delta P (V16H)

this drawing is property of Holland Lift International, by all rights reserved
 deze tekening is eigendom van Holland Lift International, by all rights reserved
 deze tekening is eigendom van Holland Lift International, by all rights reserved



Holland Lift International B.V.
 Anodeweg 1
 NL-1627 LJ Hoorn The Netherlands
 T/F +31 (0)229-285555 / 285550
 E service@hollandlift.com
 W www.hollandlift.com

Printplaat
 Leiterplatte
 Circuit Board

Projekt:	EG-20-001	Zeichnungsnummer:		Rev.:	A	erstelt von:	Rothenbusch
Datum:	28.06.2013	Antage:	=	Ort:	+	Blatt:	34