

AANSLUITKLEM KLEMMENKAST ⌀ ANSCHLUSSKLEMME KLEMMKASTEN TERMINAL CONNECTION BOX AANSLUITKLEM BEDIENINGSKAST ⌀ ANSCHLUSSKLEMME STEUERPULT TERMINAL CONTROL BOX	AANSLUITKLEM TRANSISTOR ⊕ ANSCHLUSSKLEMME TRANSISTOR TERMINAL TRANSISTOR AANSLUITKLEM PLC ⊕ ANSCHLUSSKLEMME SPS TERMINAL PLC	AANSLUITKLEM PLC-SLAVE ⌀ ANSCHLUSSKLEMME SPS-SLAVE TERMINAL PLC-SLAVE
---	---	---

TYPE	OMSCHRIJVING UMSCHREIBUNG DESCRIPTION	PLC PROG: SPS PROG: PLC PROG:
G320-ELN	FPX - Groeneveld	G-E-03A
REV.	DATUM DATUM DATE	OPMERKING BEMERKUNG REMARK
A	16-09-2016	400V PARALLEL POWER SOURCE

this drawing is property of Holland Lift International, by all rights reserved
 diese zeichnung ist eigentum von Holland Lift International, by urheberrecht vorbehalten nach dem gesetz
 deze tekening is eigendom van Holland Lift International, by auteursrecht voorbehouden volgens de wet



Holland Lift International B.V.
 Anodeweg 1
 NL-1627 LJ Hoorn The Netherlands
 T/F +31 (0)229-285555 / 285550
 E service@hollandlift.com
 W www.hollandlift.com

INDEX BLAD
 INDEX BLATT
 INDEX SHEET

Projekt:	EG-21-001	Zeichnungsnummer:	Rev.: A	erstellt von: Rothenbusch
Datum:	16.09.2016	Antage:	Ort: +	Blatt: 1

this drawing is property of Holland Lift International, by all rights reserved
 deze tekening is eigendom van Holland Lift International, by all rights reserved
 deze tekening is eigendom van Holland Lift International, by all rights reserved

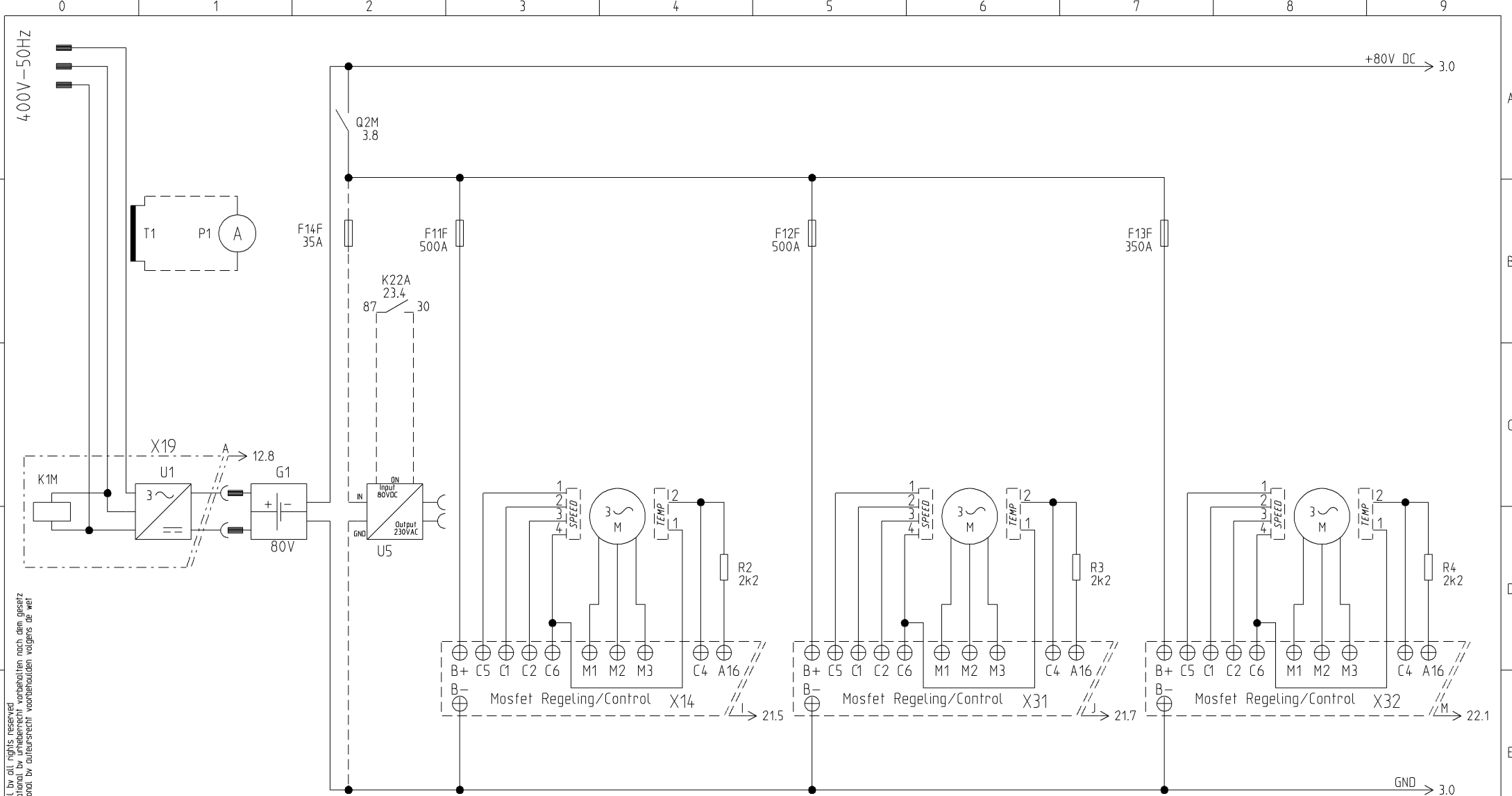

Acculader
Akkuladegeraet
Battery Charger

Ladestrom
Messung

Optie/Option

Omformer
Umformer
Converter

Optie/Option

Rijden-Heffen-Platf.-Stempels
Fahren-Heben-Platf.-Stuetzen
Driving-Lifting-Platf.-Jacks

Motor 1 - 22,3 kW

Snel Rijden-Heffen
Schnell Fahren-Heben
Fast Driving-Lifting

Motor 2 - 22,3 kW

Sturen
Lenken
Steering

Motor 3 - 22,3kW



Holland Lift International B.V.
Anodeweg 1
NL-1627 LJ Hoorn The Netherlands
T/F +31 (0)229-285555 / 285550
E service@hollandlift.com
W www.hollandlift.com

STROOMKRINGSCHEMA
STROMLAUFPLAN
CIRCUIT DIAGRAM

Projekt: EG-21-001
Datum: 16.09.2016

Zeichnungsnummer:
Anlage: =

Rev.: A
Ort: +

erstellt von: Rothenbusch
Blatt: 2

this drawing is property of Holland Lift International, by all rights reserved.
 deze tekening is eigendom van Holland Lift International, by all rights reserved.
 deze tekening is eigendom van Holland Lift International, by all rights reserved.

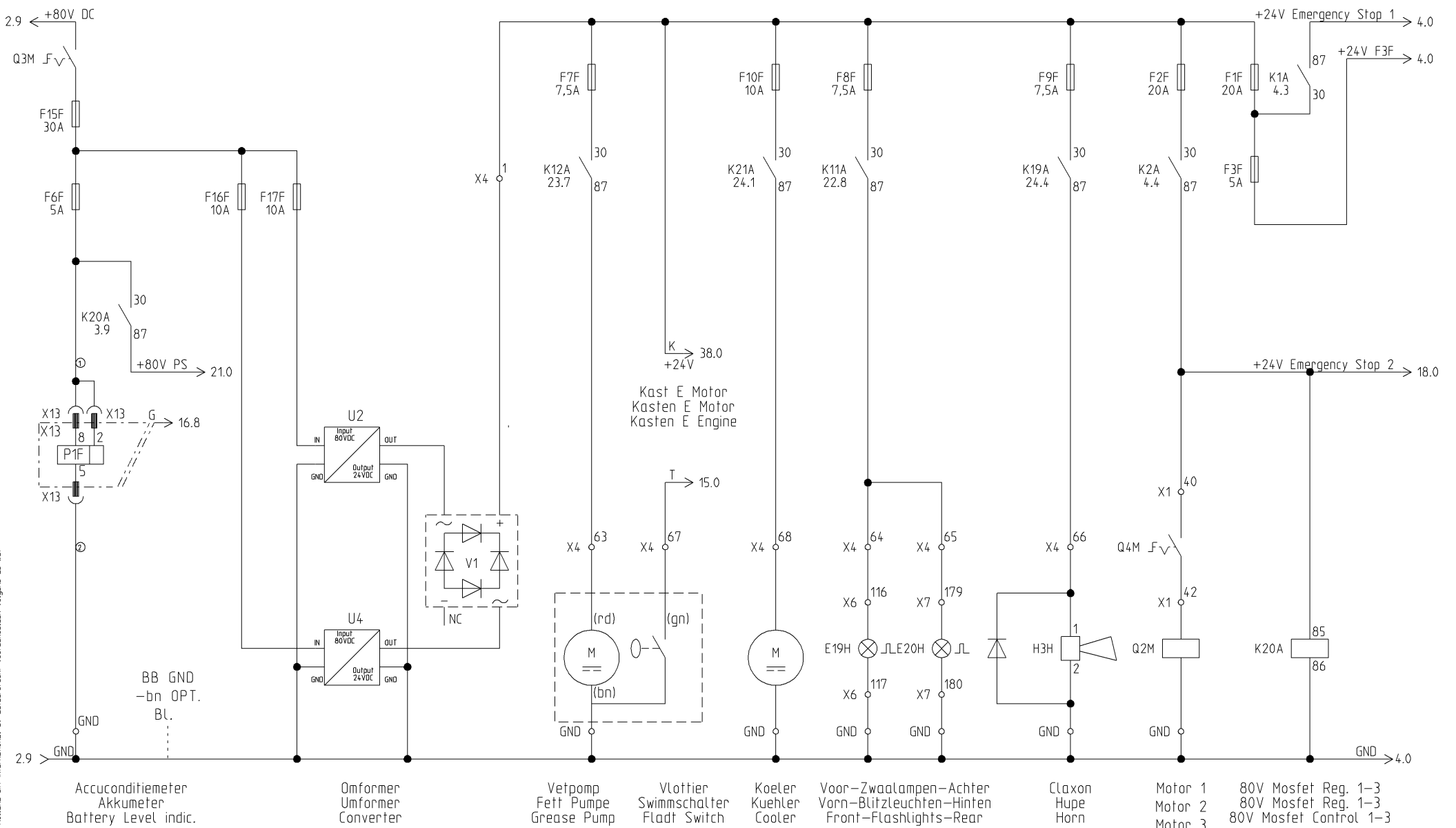

Accuconditiometer
 Akkumeter
 Battery Level indic.

Omformer
 Umformer
 Converter

Vetpomp
 Fett Pumpe
 Grease Pump

Vlottier
 Swimschalter
 Fladst Switch

Koeler
 Kuehler
 Cooler

Voor-Zwaalampen-Achter
 Vorn-Blitzleuchten-Hinten
 Front-Flashlights-Rear

Claxon
 Hupe
 Horn

Motor 1
 Motor 2
 Motor 3

80V Mosfet Reg. 1-3
 80V Mosfet Reg. 1-3
 80V Mosfet Control 1-3

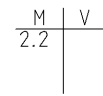

Holland Lift International B.V.
 Anodeweg 1
 NL-1627 LJ Haarn The Netherlands
 T/F +31 (0)229-285555 / 285550
 E service@hollandlift.com
 W www.hollandlift.com

STROOMKRINGSCHEMA
 STROMLAUFPLAN
 CIRCUIT DIAGRAM

Projekt:	EG-21-001	Zeichnungsnummer:	Rev.:	A	erstellt von:	Rothenbusch
Datum:	16.09.2016	Anlage:	Ort:	=	Blatt:	3

this drawing is property of Holland Lift International, by all rights reserved
 deze tekening is eigendom van Holland Lift International, by all rights reserved
 deze tekening is eigendom van Holland Lift International, by all rights reserved

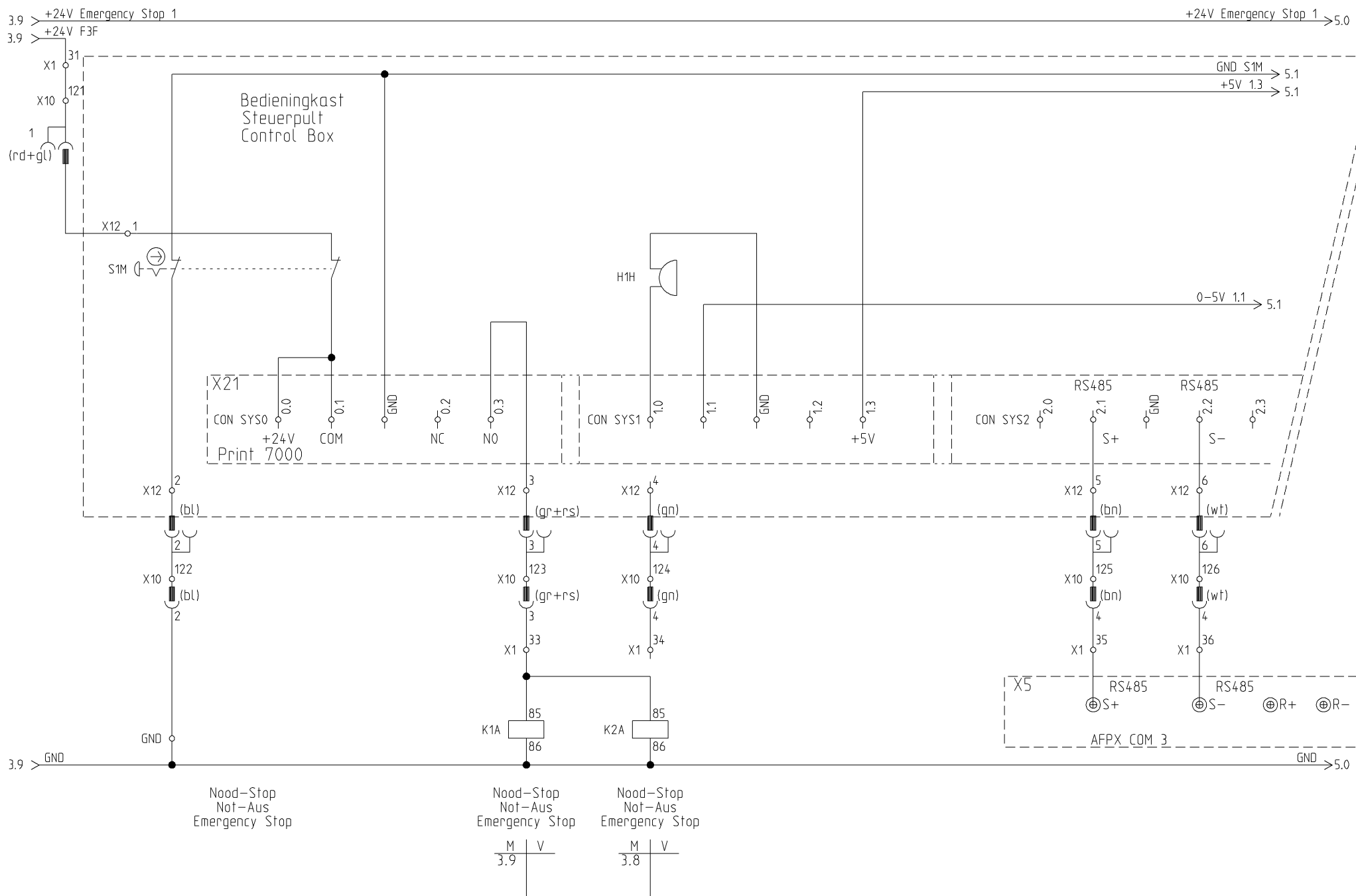

Holland Lift International B.V.
 Anodeweg 1
 NL-1627 LJ Hoorn The Netherlands
 T/F +31 (0)229-285555 / 285550
 E service@hollandlift.com
 W www.hollandlift.com

STROOMKRINGSCHEMA
STROMLAUFPLAN
CIRCUIT DIAGRAM

Projekt:	EG-21-001	Zeichnungsnummer:	Rev.:	A	erstellt von:	Rothenbusch
Datum:	16.09.2016	Anlage:	Ort:	+	Blatt:	4

4.9 > +24V Emergency Stop 1

+24V Emergency Stop 1 > 6.0

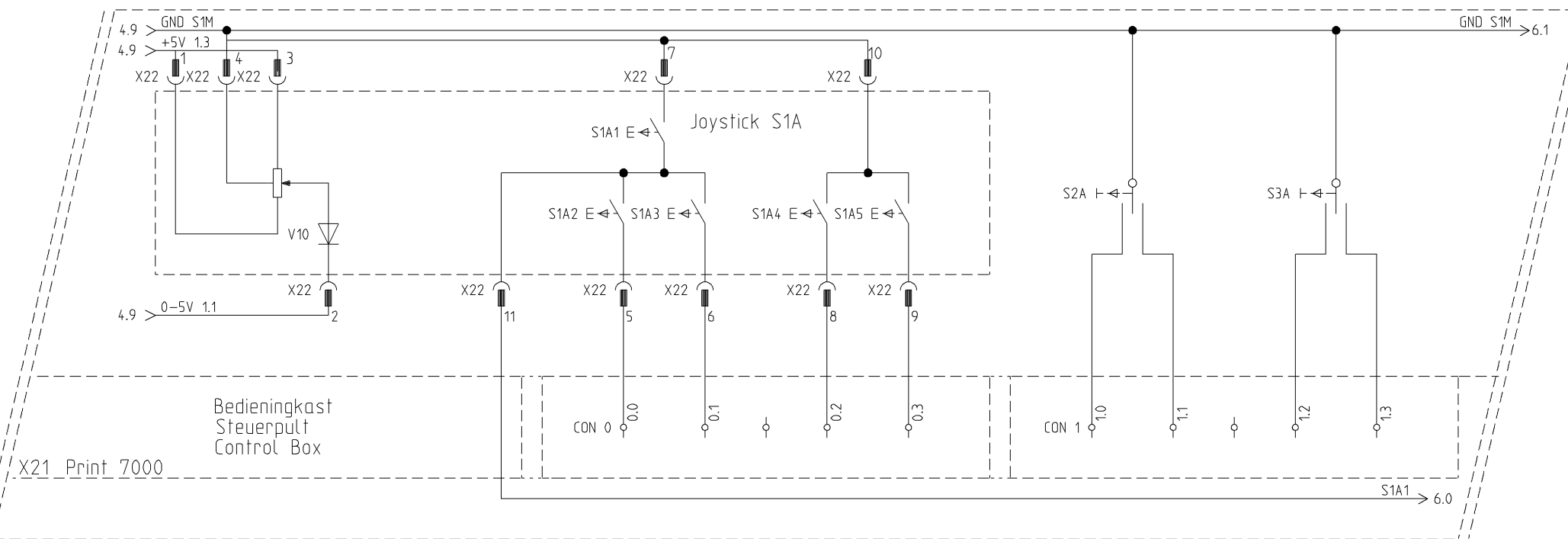

Bedieningkast
Steuerepult
Control Box

X21 Print 7000

4.9 > GND

GND > 6.0

S1A1 Dodemansknop
S1A1 Totmansknop
S1A1 Dead Man's Button

Op-Joystick-Neer
Auf-Joystick-Nieder
On-Joystick-Down

Links - Rechts
Links - Rechts
Left - Right

Claxon-Sign.gever
Hupe-Signalgeber
Horn-Signal

Sper/Diff
Sperr/Diff
Slip/Diff

Rijden-Heffen-Platf.
Fahren-Heben-Platf.
Driving-Lifting-Platf.

Sturen Voor
Lenken Vorn
Steering Front

— Mode Select —

this drawing is property of Holland Lift International, by all rights reserved
 deze tekening is eigendom van Holland Lift International, by all rights reserved
 deze tekening is eigendom van Holland Lift International, by all rights reserved

5.9 > +24V Emergency Stop 1 +24V Emergency Stop 1 > 7.0

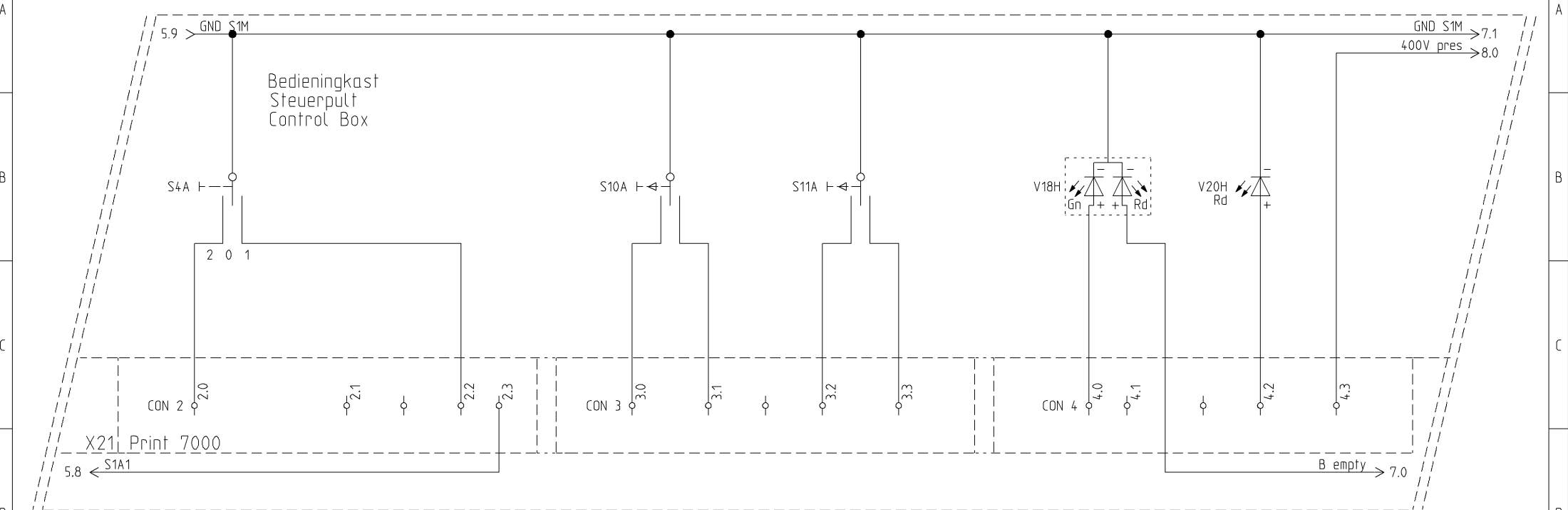

Bedieningkast
Steuerpult
Control Box

S4A		
0 = Langzaam	Langsam	Slow
1 = Normal	Normal	Normal
2 = Snel	Schnell	Fast

this drawing is property of Holland Lift International, by all rights reserved
 diese zeichnung ist eigentum von Holland Lift International, by urheberrecht vorbehalten
 deze tekening is eigendom van Holland Lift International, by auteursrecht voorbehouden volgens de wet

5.9 > GND GND > 7.0

Snelheid Geschwindigkeit Speed	S1A1 Dodemansknop S1A1 Totmansknopf S1A1 Dead Man, s Button	Links - Rechts Links - Rechts Left - Right	4xN-Stempels-Autom. Niveleer 4xN-Stuetzen-Autom. Nivel. 4xN-Jack-Autom. Nivel	Accu geladen Akku geladen Battery loaded	Accu leeg Akku leer Battery empty	Storing 400V Motor Stoerung 400V Motor Failure 400V Engine	400V aanwezig 400V anwesend 400V present
Sturen Achter Lenken Hinten Steering Rear							



Holland Lift International B.V.
Anodeweg 1
NL-1627 LJ Hoorn The Netherlands
T/F +31 (0)229-285555 / 285550
E service@hollandlift.com
W www.hollandlift.com

STROOMKRINGSHEMA
STROMLAUFPLAN
CIRCUIT DIAGRAM

Projekt: EG-21-001	Zeichnungsnummer:	Rev.: A	erstellt von: Rothenbusch
Datum: 16.09.2016	Anlage: =	Ort: +	Blatt: 6

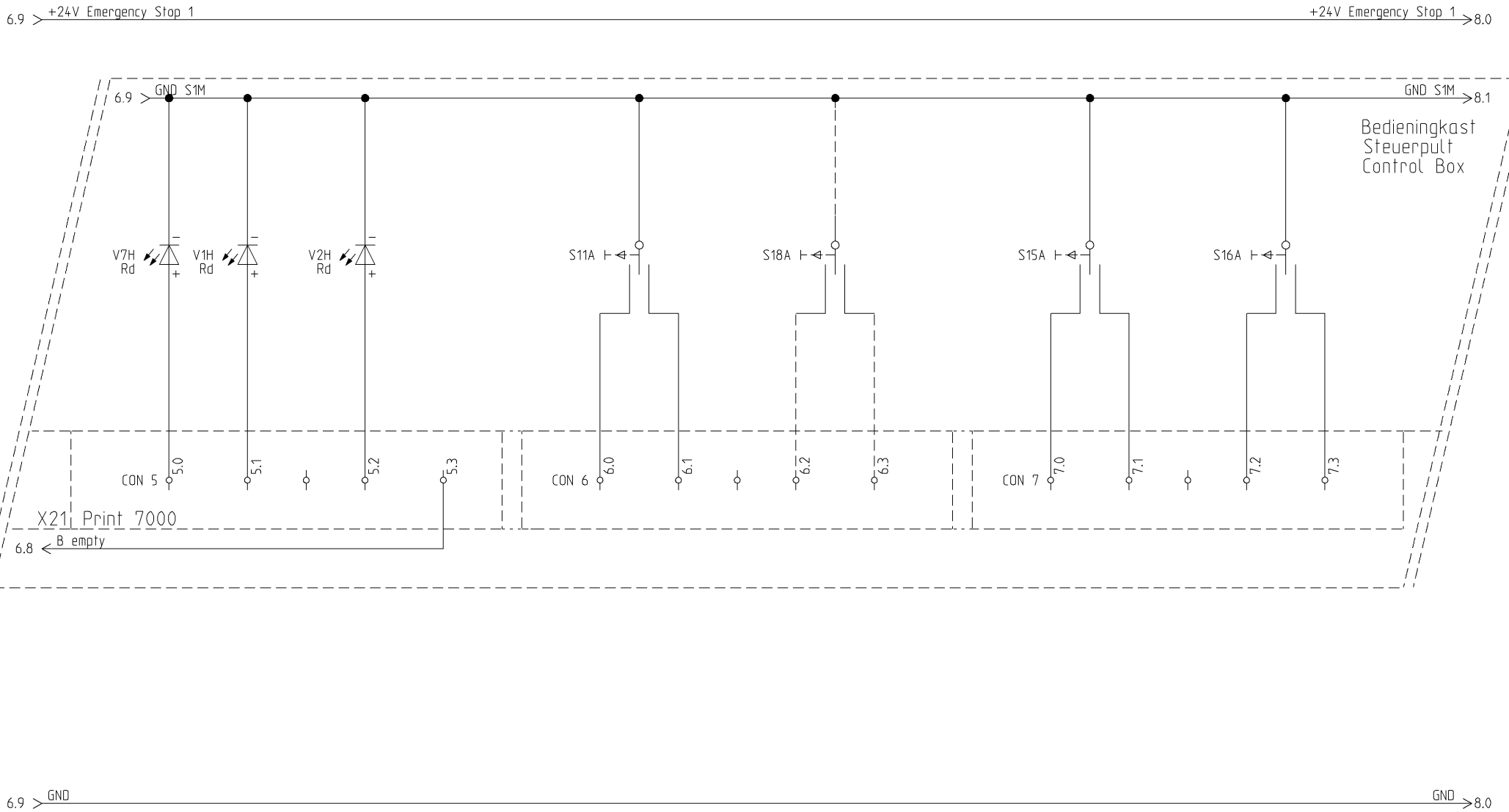

Vetpomp	Overload	Scheefstand	Accu leeg	Start - 400V M - Stop	Uit	Omformer	Aan	LA in	LA uit	RA in	RA uit
Fett Pumpe	Ueberlastung	Neigung	Akku leer	Start - 400V M - Stop	Aus	Umformer	An	LH ein	LH aus	RH ein	RH aus
Grease Pump	Overload	Grade/Slope	Battery empty	Start - 400V E - Stop	Off	Converter	On	LR in	LR out	RR in	RR out

Optie/Option Stempels-Stuetzen-Jacks Stempels-Stuetzen-Jacks

this drawing is property of Holland Lift International, by all rights reserved
 deze tekening is eigendom van Holland Lift International, by auteursrecht voorbehouden volgens de wet
 deze tekening is eigendom van Holland Lift International, by auteursrecht voorbehouden volgens de wet



Holland Lift International B.V.
 Anodeweg 1
 NL-1627 LJ Hoorn The Netherlands
 T/F +31 (0)229-285555 / 285550
 E service@hollandlift.com
 W www.hollandlift.com

STROOMKRINGSHEMA
 STROMLAUFPLAN
 CIRCUIT DIAGRAM

Projekt:	EG-21-001	Zeichnungsnummer:	Rev.:	A	erstellt von:	Rothenbusch
Datum:	16.09.2016	Anlage:	Ort:	=	Blatt:	7

7.9 > +24V Emergency Stop 1 +24V Emergency Stop 1 > 9.0

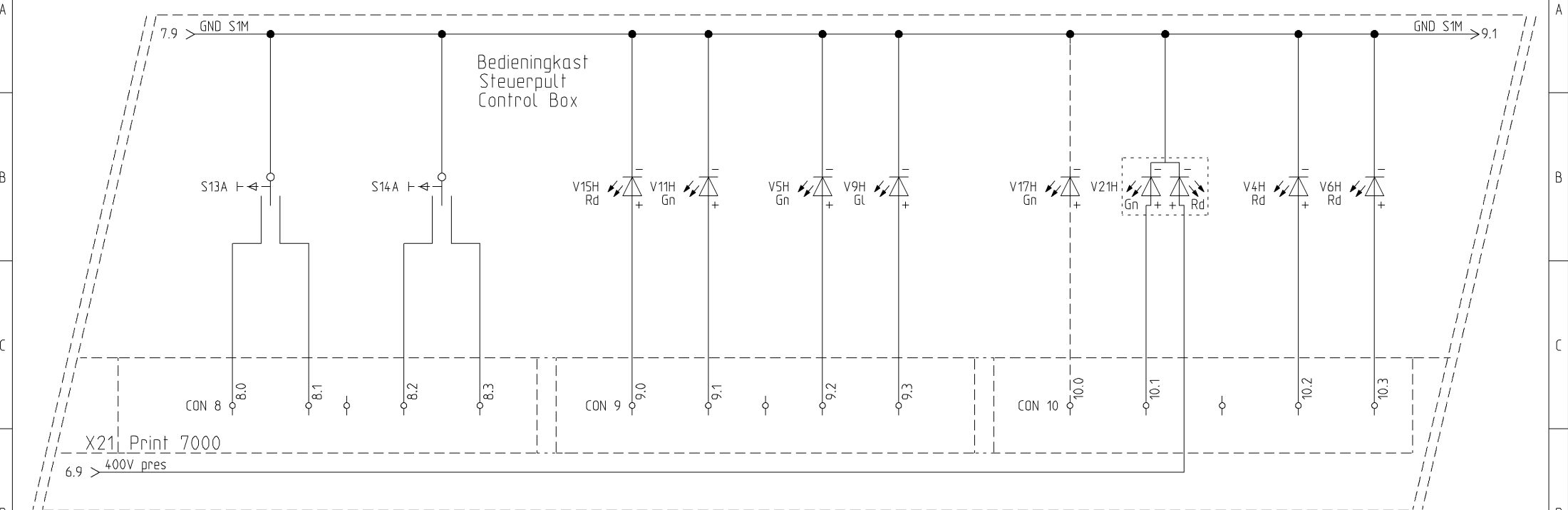

V21H	
gn: 400V M run	gl: 400V aanwezig
gn: 400V M run	gl: 400V anwesend
gn: 400V E run	yl: 400V present

7.9 > GND GND > 9.0

LV in	LV uit	RV in	RV uit	8 mtr. Afslag	Stempels in	Stempels uit	Autom. Niv.	Omformer Aan	400V M Run	Achter Horizontaal Platform uit
LV ein	LV aus	RV ein	RV aus	8 mtr. Ausschalt.	Stuetzen ein	Stuetzen aus	Autom. Niv.	Umformer An	400V M Run	Hinten Achse Hor. Plattform aus
LF in	LF out	RF in	RF out	8 mtr. Cut-Out	Jacks in	Jacks out	Autom. Niv.	Converter On	400V E Run	Rear Axle Hor. Plattform out

Stempels-Stuetzen-Jacks Stempels-Stuetzen-Jacks Optie/Option

this drawing is property of Holland Lift International, by all rights reserved
 deze tekening is eigendom van Holland Lift International, by all rights reserved
 deze tekening is eigendom van Holland Lift International, by all rights reserved



Holland Lift International B.V.
 Anodeweg 1
 NL-1627 LJ Hoorn The Netherlands
 T/F +31 (0)229-285555 / 285550
 E service@hollandlift.com
 W www.hollandlift.com

STROOMKRINGSHEMA
 STROMLAUFPLAN
 CIRCUIT DIAGRAM

Projekt:	EG-21-001	Zeichnungsnummer:	Rev.:	A	erstellt von:	Rothenbusch
Datum:	16.09.2016	Anlage:	Ort:	=	Blatt:	8

this drawing is property of Holland Lift International, by all rights reserved
 deze tekening is eigendom van Holland Lift International, by all rights reserved
 deze tekening is eigendom van Holland Lift International, by auteursrecht voorbehouden volgens de wet

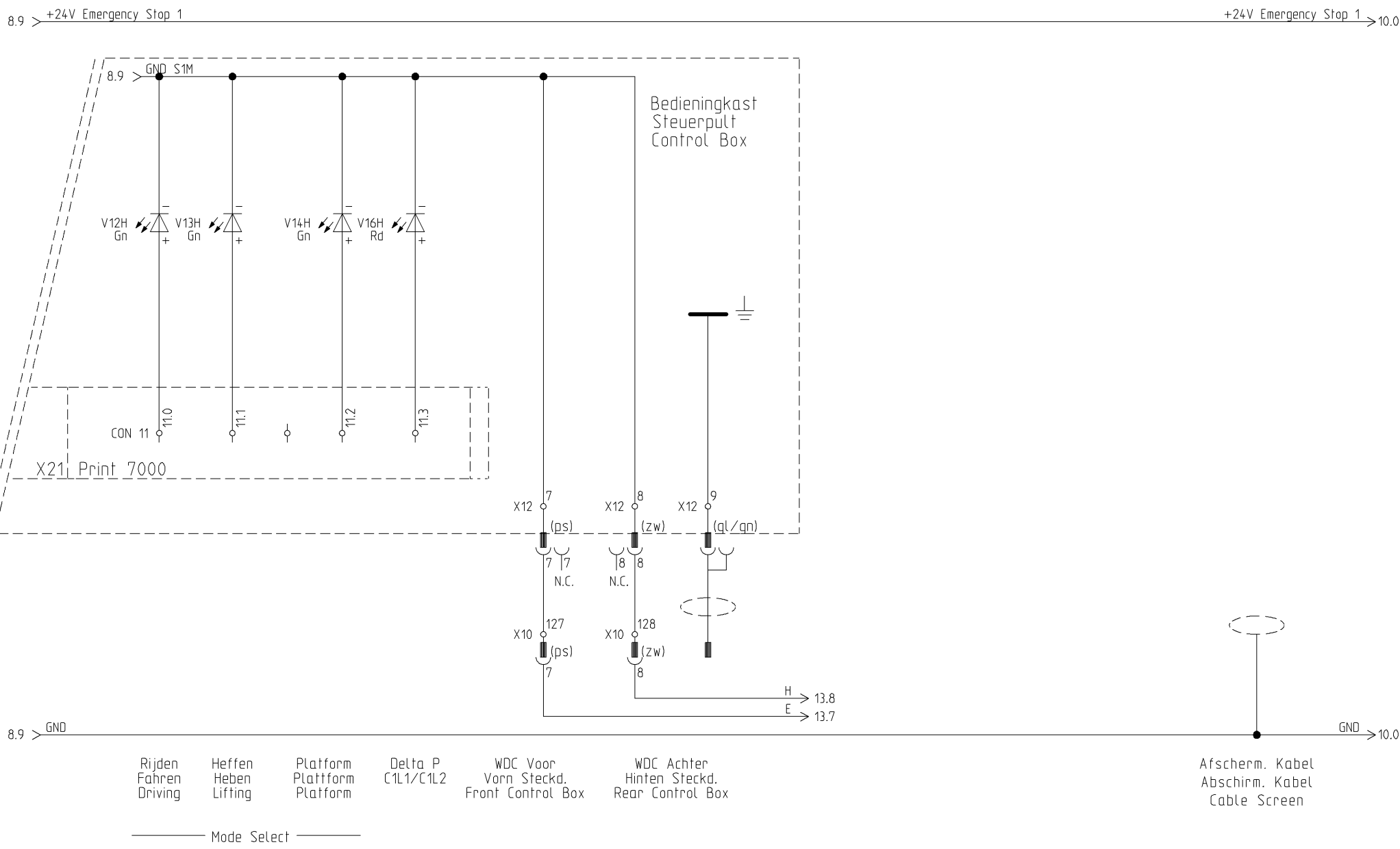

Rijden Fahren Driving	Heffen Heben Lifting	Plattform Plattform Plattform	Delta P C1L1/C1L2	WDC Voor Vorn Steckd. Front Control Box	WDC Achter Hinten Steckd. Rear Control Box	Afscherm. Kabel Abschirm. Kabel Cable Screen
-----------------------------	----------------------------	-------------------------------------	----------------------	---	--	--

this drawing is property of Holland Lift International, by all rights reserved.
 deze tekening is eigendom van Holland Lift International, by all rights reserved.
 deze tekening is eigendom van Holland Lift International, by all rights reserved.

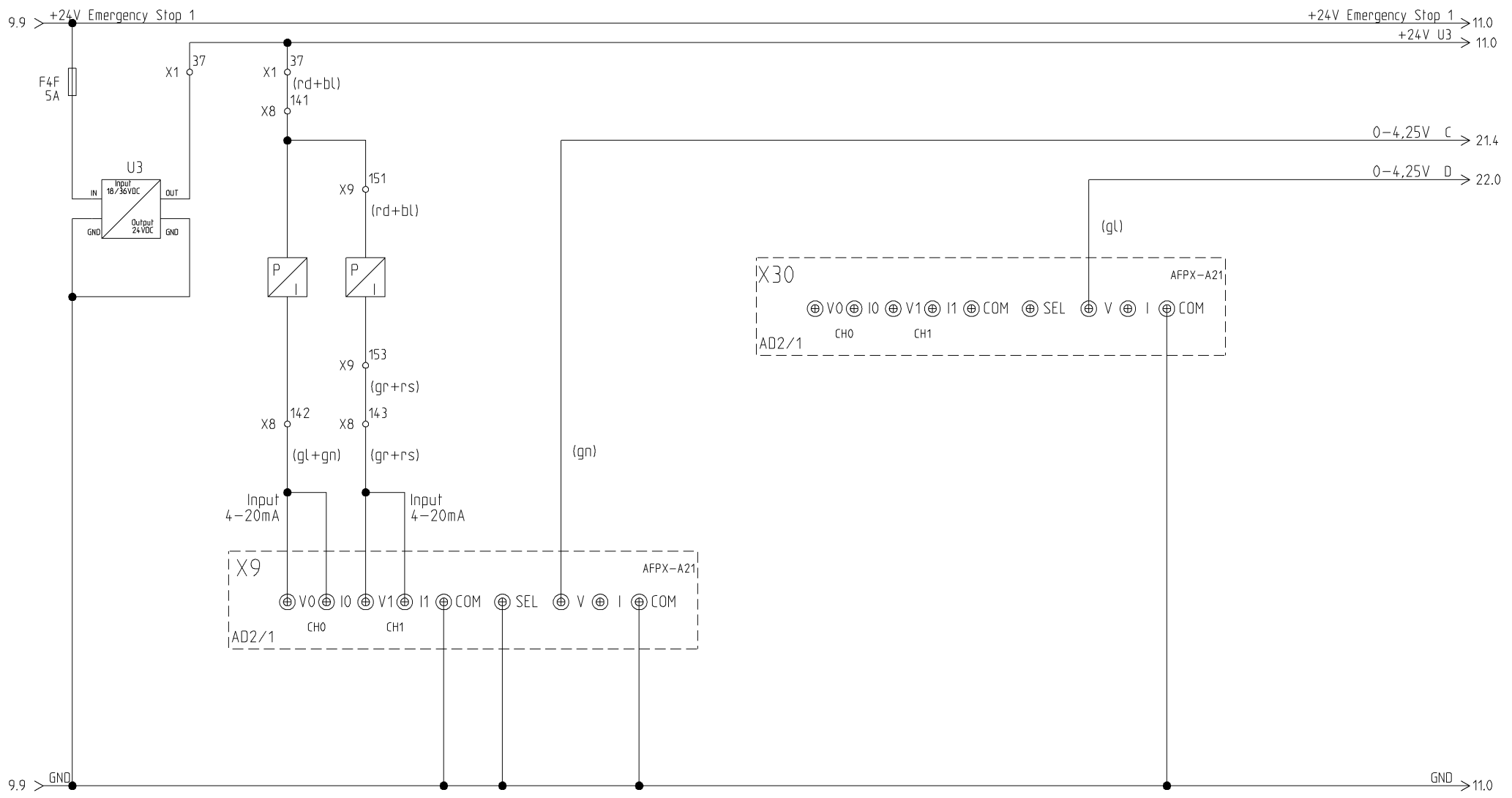

Druk Meting Cyl. 1	Druk Meting Cyl. 2	Rijden/Heffen/Platform/Stempels	Sturen/Dalen/Prop. Vent 400V Motor
Druck Messung Zyl. 1	Druck Messung Zyl. 2	Fahren/Heben/Plattform/Stuetzen	Lenken/Senken/Prop. Vent 400V Motor
Pressure Measuring Cyl. 1	Pressure Measuring Cyl. 2	Driving/Lift Up/Platform/Jacks	Steering/Lift Down/Prop. Valve 400V Engine



Holland Lift International B.V.
 Anodeweg 1
 NL-1627 LJ Hoorn The Netherlands
 T/F +31 (0)229-285555 / 285550
 E service@hollandlift.com
 W www.hollandlift.com

STROOMKRINGSCHEMA
 STROMLAUFPLAN
 CIRCUIT DIAGRAM

Projekt:	EG-21-001	Zeichnungsnummer:	Rev.:	A	erstellt von:	Rothenbusch
Datum:	16.09.2016	Anlage:	Ort:	=	Blatt:	10

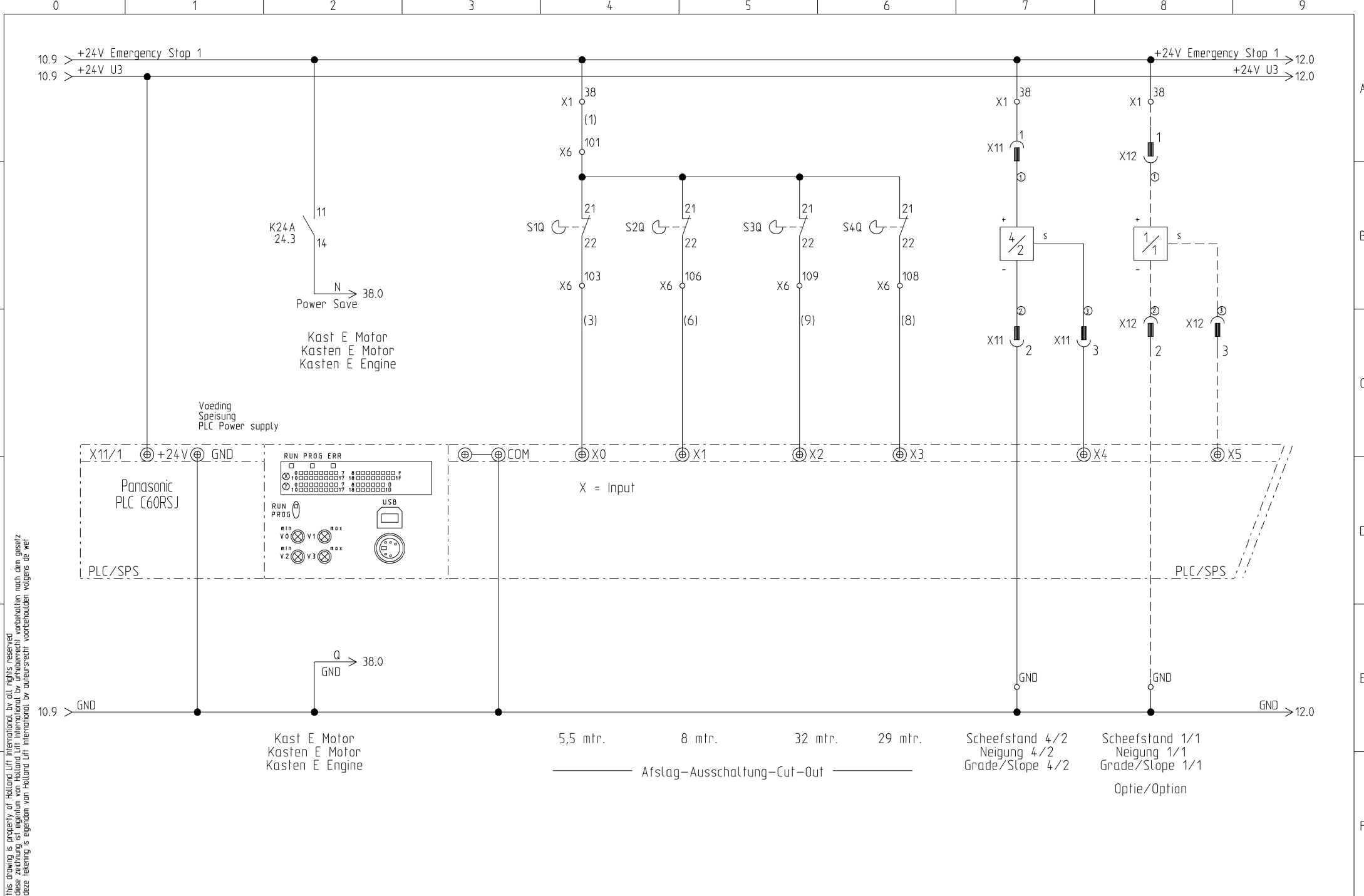

this drawing is property of Holland Lift International, by all rights reserved.
 deze tekening is eigendom van Holland Lift International, by all rights reserved.
 deze tekening is eigendom van Holland Lift International, by all rights reserved.

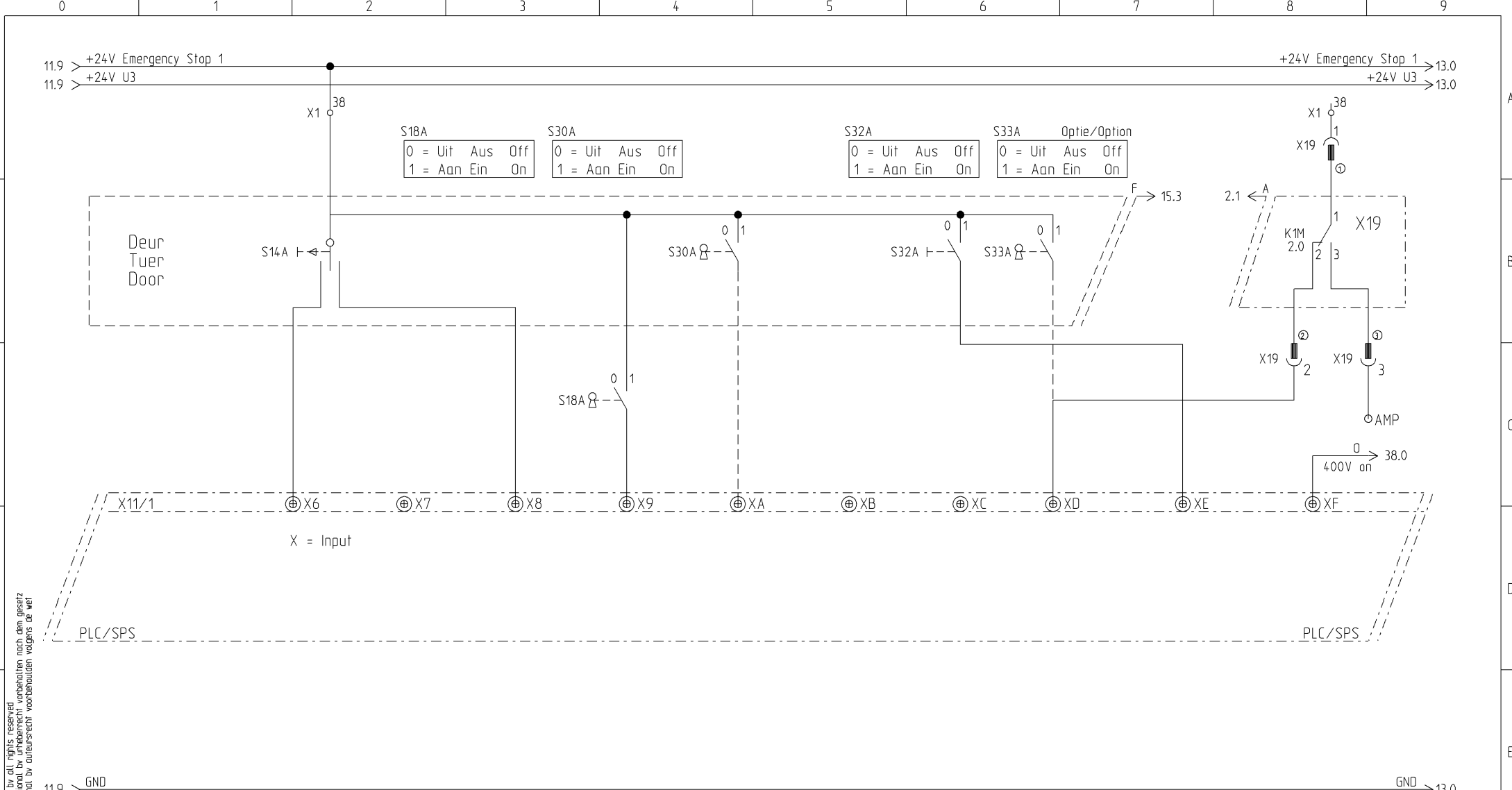

S18A
 0 = Uit Aus Off
 1 = Aan Ein On

S30A
 0 = Uit Aus Off
 1 = Aan Ein On

S32A
 0 = Uit Aus Off
 1 = Aan Ein On

S33A Optie/Option
 0 = Uit Aus Off
 1 = Aan Ein On

this drawing is property of Holland Lift International, by all rights reserved
 deze tekening is eigendom van Holland Lift International, by all rights reserved
 deze tekening is eigendom van Holland Lift International, by all rights reserved

Heffen - Dalem
 Heben - Senken
 Lift Up - Lift Down

Overlastin
 Ueberlastung
 Overload

Ri. max. Hoogte
 Fa. max. Hoehe
 Dr. max. Height

Reserve
 Reserve
 Spare

Reserve Acculader
 Reserve Akkuladegeraet
 Spare Battery Charger

Overbr. Plattf. in
 Ueberbr. Plattf. ein
 Override Plattf. in

400V aanwezig
 400V anwesend
 400V present

Optie/Option



Holland Lift International B.V.
 Anodeweg 1
 NL-1627 LJ Hoorn The Netherlands
 T/F +31 (0)229-285555 / 285550
 E service@hollandlift.com
 W www.hollandlift.com

STROOMKRINGSHEMA
 STROMLAUFPLAN
 CIRCUIT DIAGRAM

Projekt: EG-21-001
 Datum: 16.09.2016

Zeichnungsnummer:
 Anlage: =

Rev.: A
 Ort: +

erstellt von: Rothenbusch
 Blatt: 12

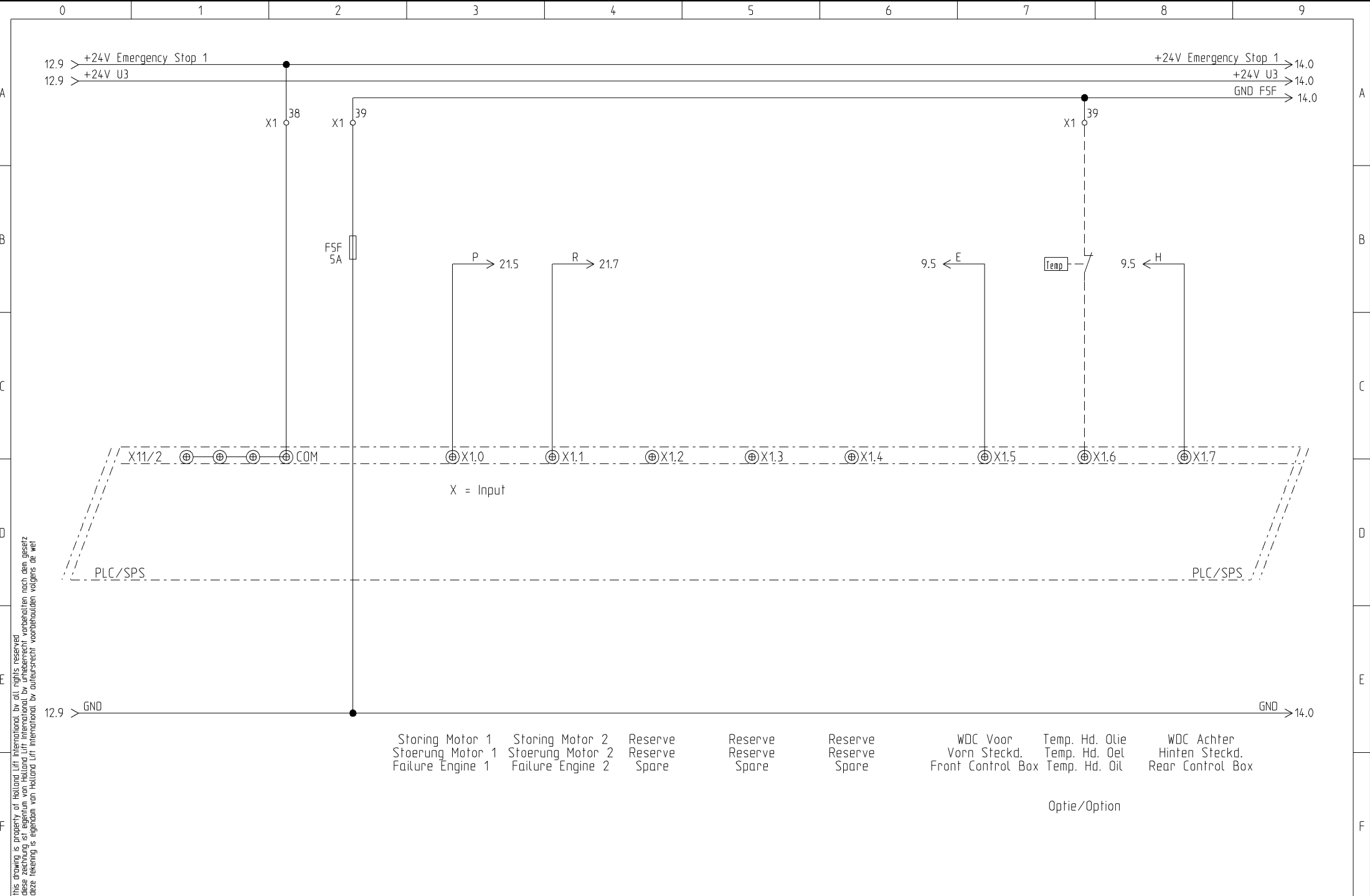

this drawing is property of Holland Lift International, by all rights reserved
 deze tekening is eigendom van Holland Lift International, by auteursrecht voorbehouden volgens de wet
 deze tekening is eigendom van Holland Lift International, by auteursrecht voorbehouden volgens de wet



Holland Lift International B.V.
 Anodeweg 1
 NL-1627 LJ Hoorn The Netherlands
 T/F +31 (0)229-285555 / 285550
 E service@hollandlift.com
 W www.hollandlift.com

STROOMKRINGSHEMA
 STROMLAUFPLAN
 CIRCUIT DIAGRAM

Projekt:	EG-21-001	Zeichnungsnummer:	Rev.:	A	erstellt von:	Rothenbusch
Datum:	16.09.2016	Anlage:	Ort:	=	Blatt:	13

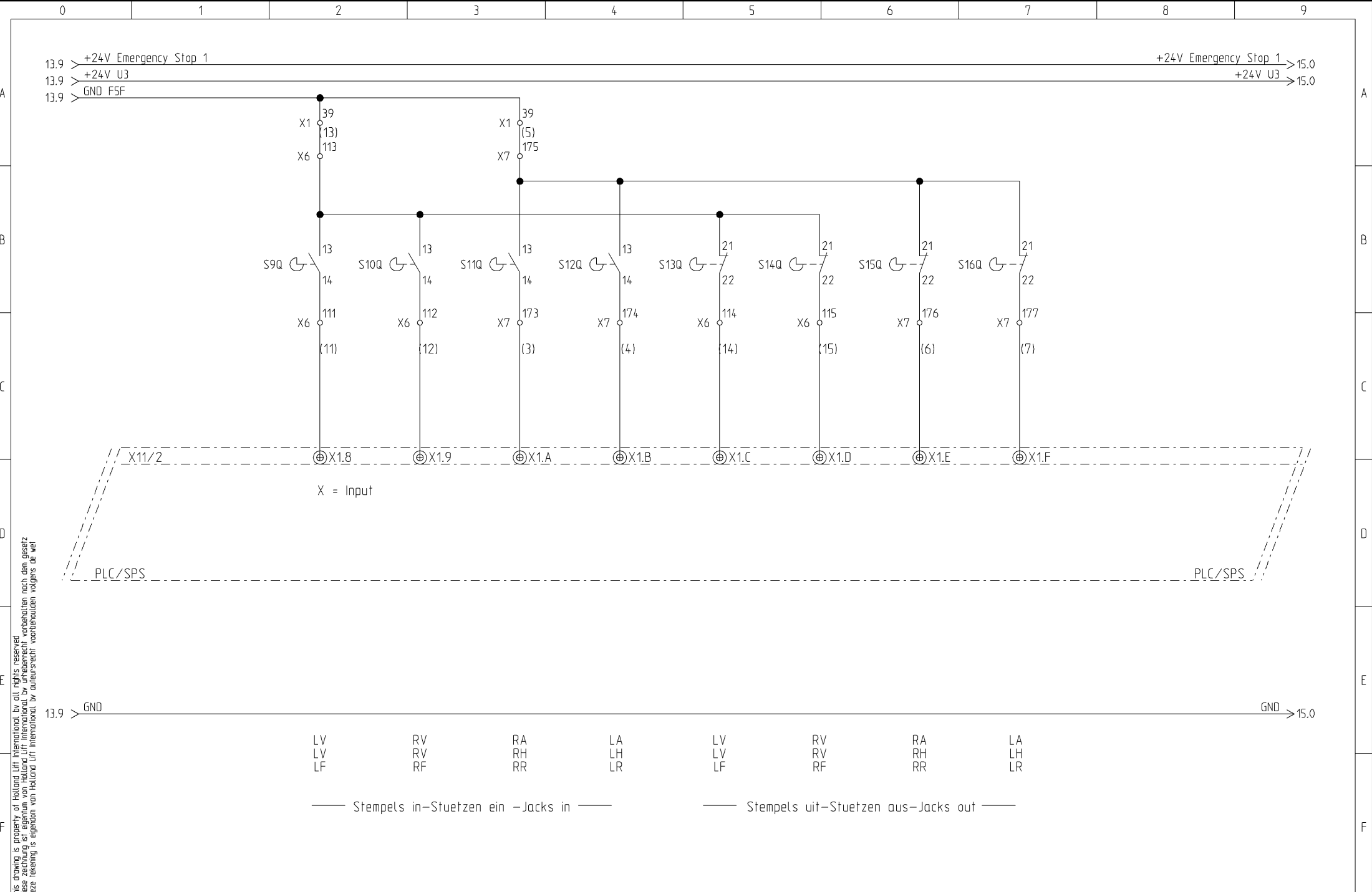

this drawing is property of Holland Lift International, by all rights reserved
 deze tekening is eigendom van Holland Lift International, by all rights reserved
 deze tekening is eigendom van Holland Lift International, by all rights reserved



Holland Lift International B.V.
 Anodeweg 1
 NL-1627 LJ Hoorn The Netherlands
 T/F +31 (0)229-285555 / 285550
 E service@hollandlift.com
 W www.hollandlift.com

STROOMKRINGSHEMA
 STROMLAUFPLAN
 CIRCUIT DIAGRAM

Projekt:	EG-21-001	Zeichnungsnummer:	Rev.:	A	erstellt von:	Rothenbusch	
Datum:	16.09.2016	Anlage:	=	Ort:	+	Blatt:	14

this drawing is property of Holland Lift International, by all rights reserved
 deze tekening is eigendom van Holland Lift International, by auteursrecht voorbehouden volgens de wet
 deze tekening is eigendom van Holland Lift International, by auteursrecht voorbehouden volgens de wet

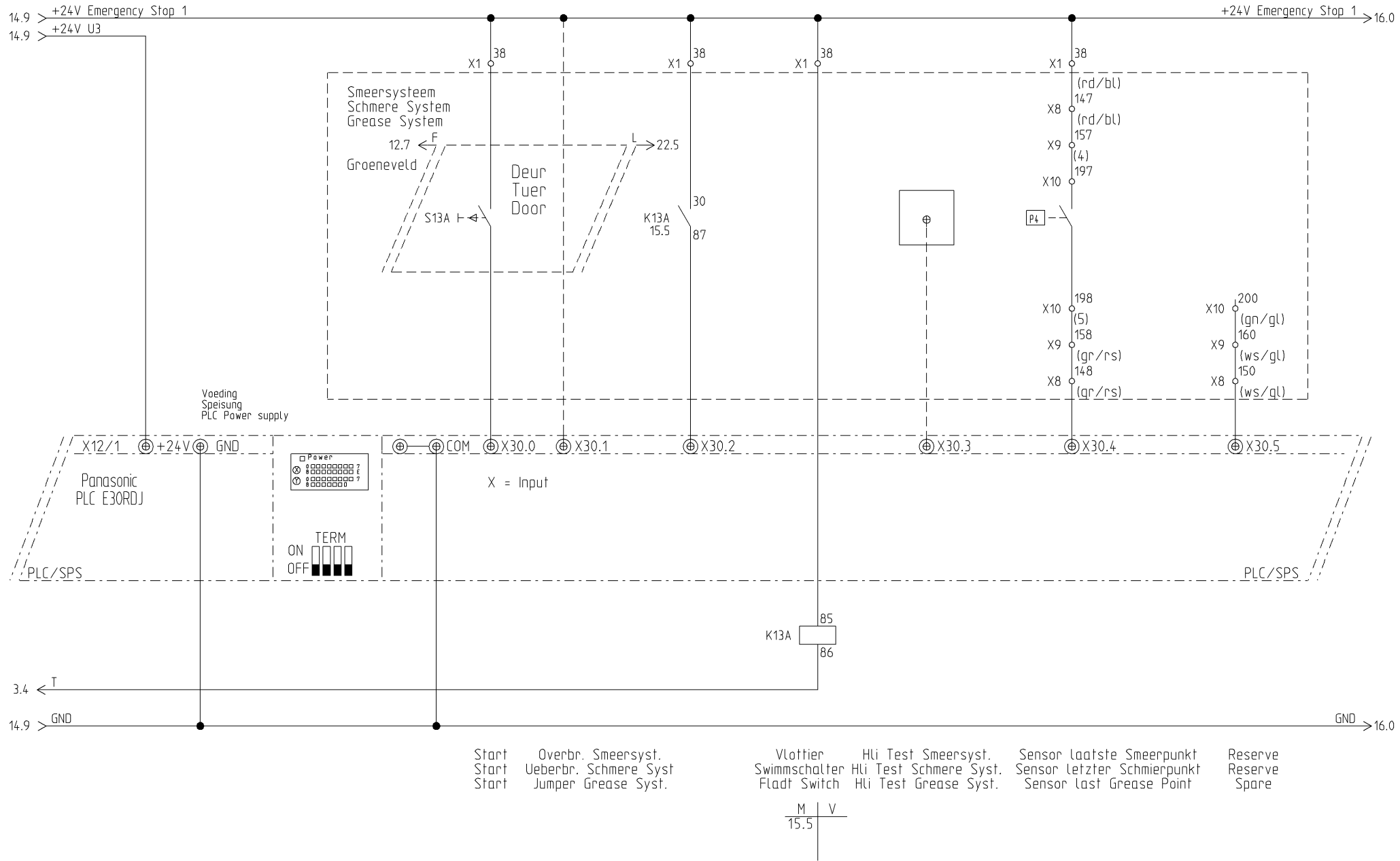

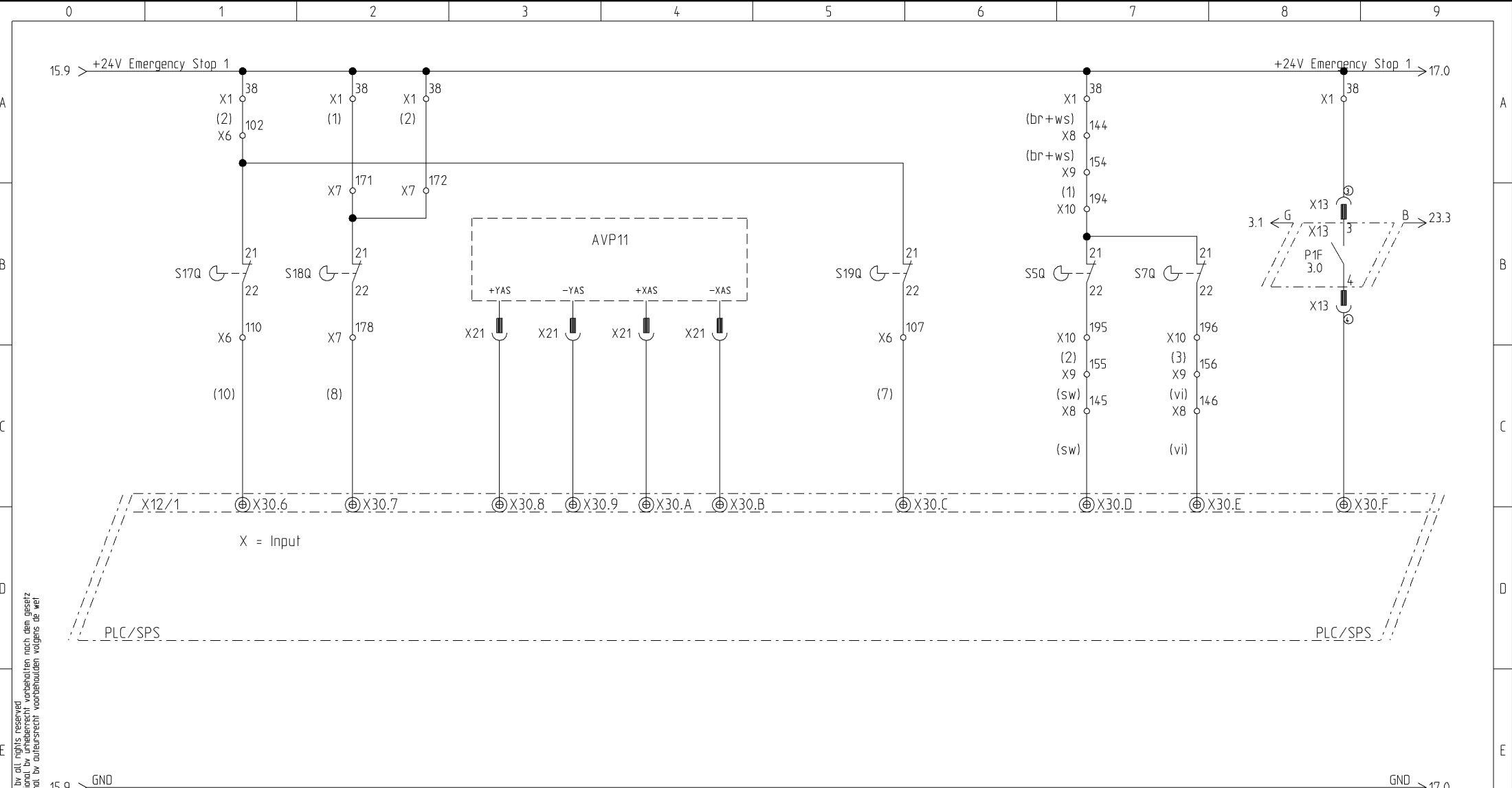

this drawing is property of Holland Lift International, by all rights reserved.
 deze tekening is eigendom van Holland Lift International, by all rights reserved.
 deze tekening is eigendom van Holland Lift International, by all rights reserved.

Vooras - Horizontaal - Achteras
 Vorn - Achse Hor. - Hinten
 Front - Axle Hor. - Rear

Autom. Waterpas
 Autom. Horizontal
 Autom. Level

Stempels Afslag 6mtr.
 Ausschaltung Stuetzen 6mtr.
 Cut-Out Jacks 6mtr.

Platform in
 Plattform ein
 Platform in

Overload
 Ueberlastung
 Overload

Accuconditiemeter
 Akkumeter
 Battery Level indic.



Holland Lift International B.V.
 Anodeweg 1
 NL-1627 LJ Hoorn The Netherlands
 T/F +31 (0)229-285555 / 285550
 E service@hollandlift.com
 W www.hollandlift.com

STROOMKRINGSHEMA
 STROMLAUFPLAN
 CIRCUIT DIAGRAM

Projekt:	EG-21-001	Zeichnungsnummer:	Rev.:	A	erstellt von:	Rothenbusch
Datum:	16.09.2016	Anlage:	Ort:	=	Blatt:	16

this drawing is property of Holland Lift International, by all rights reserved.
 deze tekening is eigendom van Holland Lift International, by auteursrecht voorbehouden volgens de wet.
 deze tekening is eigendom van Holland Lift International, by auteursrecht voorbehouden volgens de wet.

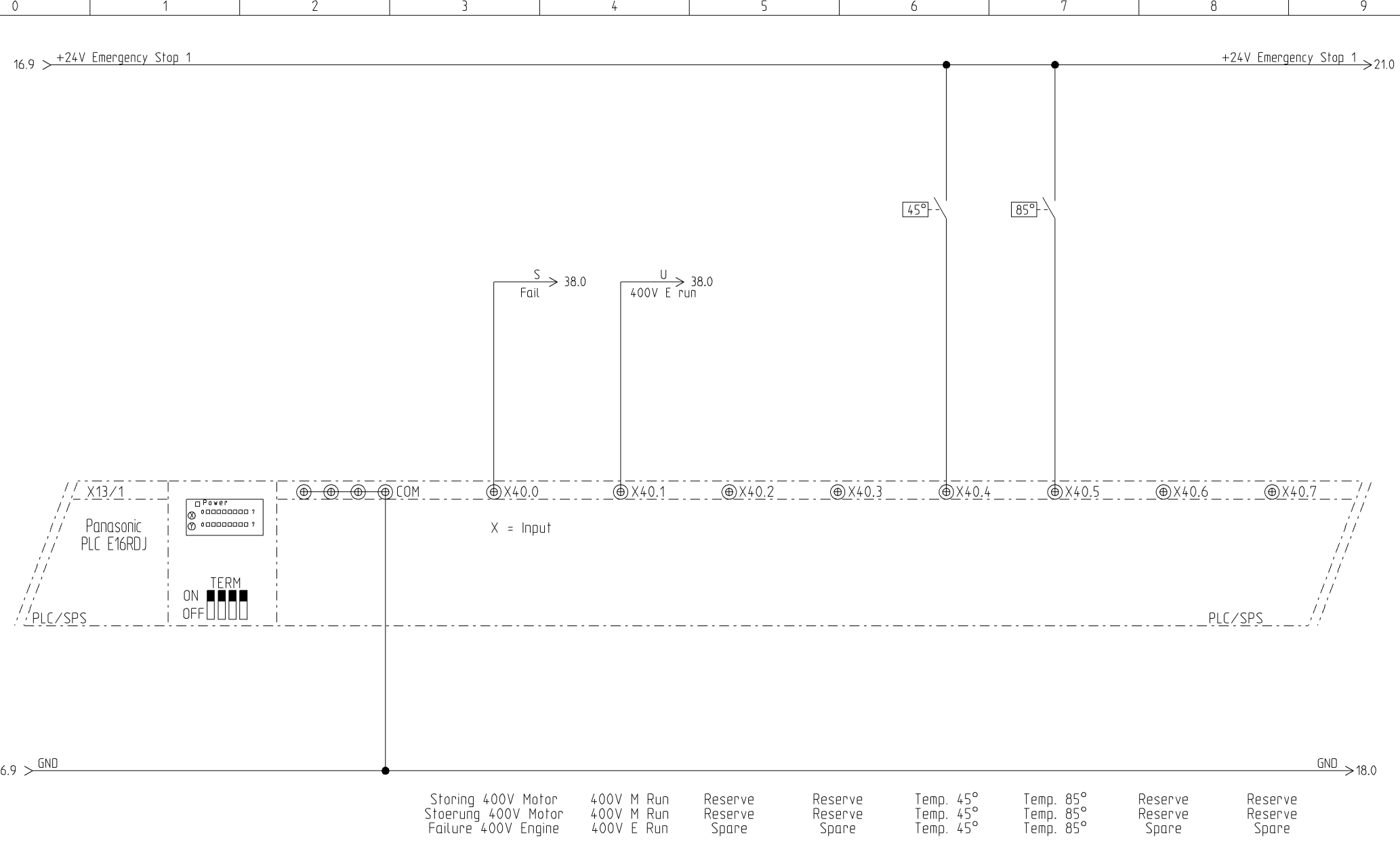

Storing 400V Motor	400V M Run	Reserve	Reserve	Temp. 45°	Temp. 85°	Reserve	Reserve
Stoerung 400V Motor	400V M Run	Reserve	Reserve	Temp. 45°	Temp. 85°	Reserve	Reserve
Failure 400V Engine	400V E Run	Spare	Spare	Temp. 45°	Temp. 85°	Spare	Spare



Holland Lift International B.V.
 Anodeweg 1
 NL-1627 LJ Hoorn The Netherlands
 T/F +31 (0)229-285555 / 285550
 E service@hollandlift.com
 W www.hollandlift.com

STROOMKINGSCHEMA
 STROMLAUFPLAN
 CIRCUIT DIAGRAM

Projekt:	EG-21-001	Zeichnungsnummer:	Rev.:	A	erstellt von:	Rothenbusch	
Datum:	16.09.2016	Anlage:	=	Ort:	+	Blatt:	17

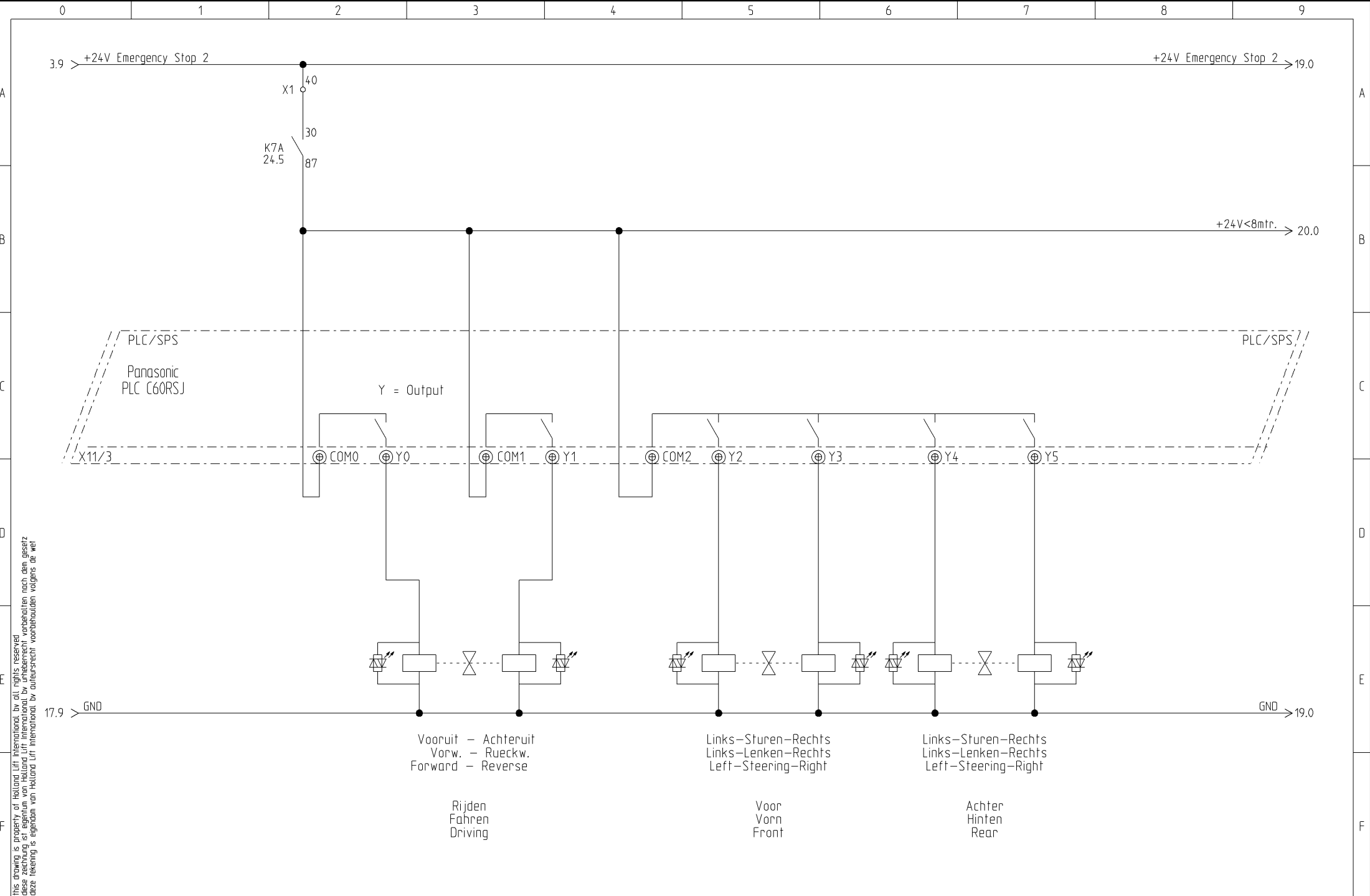

this drawing is property of Holland Lift International, by all rights reserved.
 diese zeichnung ist eigentum von Holland Lift International, by urheberrecht vorbehalten nach dem gesetz.
 deze tekening is eigendom van Holland Lift International, by auteursrecht voorbehouden volgens de wet.



Holland Lift International B.V.
 Anodeweg 1
 NL-1627 LJ Hoorn The Netherlands
 T/F +31 (0)229-285555 / 285550
 E service@hollandlift.com
 W www.hollandlift.com

STROOMKRINGSCHEMA
 STROMLAUFPLAN
 CIRCUIT DIAGRAM

Projekt:	EG-21-001	Zeichnungsnummer:	Rev.:	A	erstellt von:	Rothenbusch	
Datum:	16.09.2016	Anlage:	=	Ort:	+	Blatt:	18

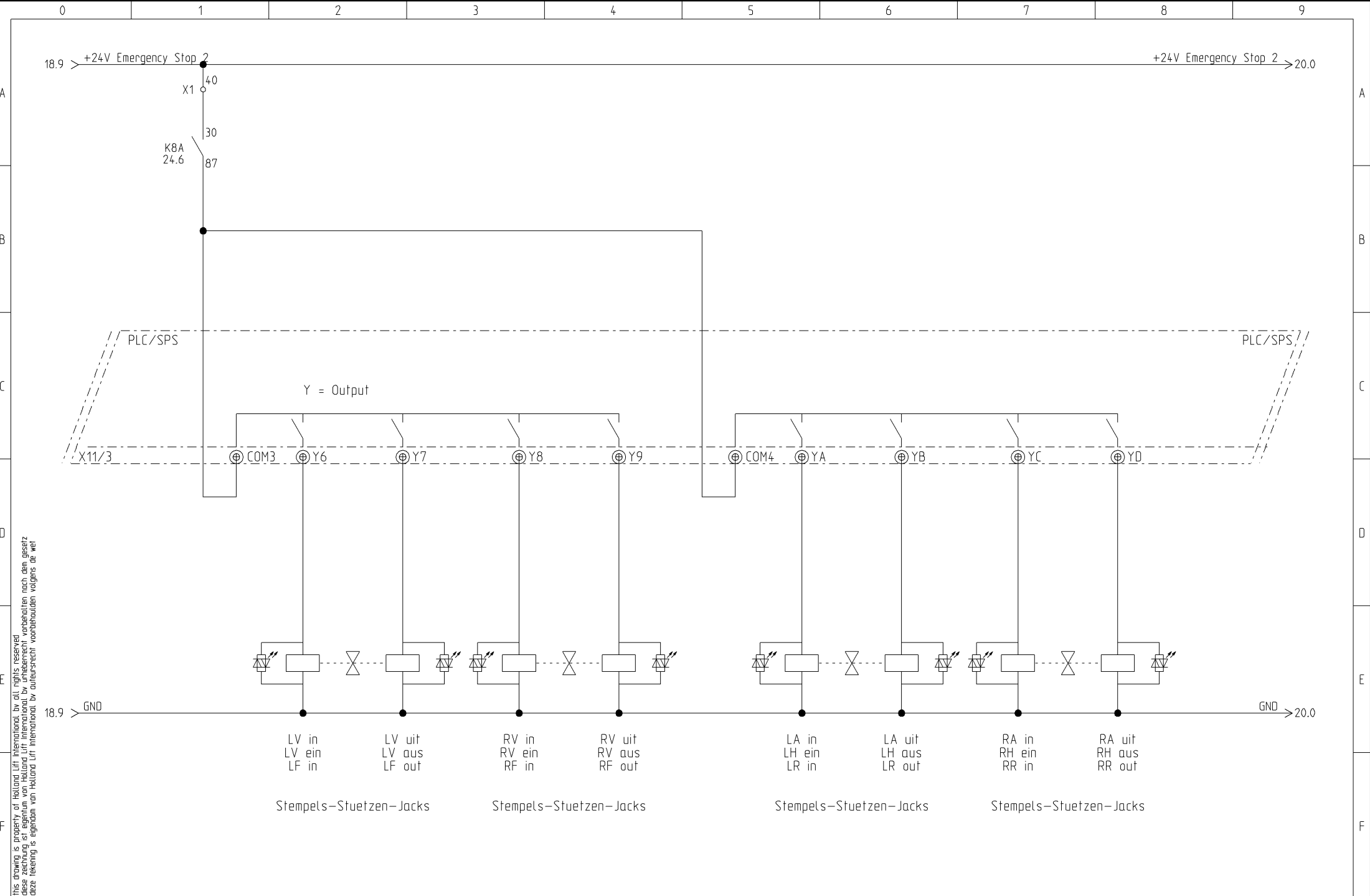

this drawing is property of Holland Lift International, by all rights reserved
 deze tekening is eigendom van Holland Lift International, by auteursrecht voorbehouden volgens de wet
 deze tekening is eigendom van Holland Lift International, by auteursrecht voorbehouden volgens de wet



Holland Lift International B.V.
 Anodeweg 1
 NL-1627 LJ Hoorn The Netherlands
 T/F +31 (0)229-285555 / 285550
 E service@hollandlift.com
 W www.hollandlift.com

STROOMKRINGSCHEMA
 STROMLAUFPLAN
 CIRCUIT DIAGRAM

Projekt:	EG-21-001	Zeichnungsnummer:	Rev.:	A	erstellt von:	Rothenbusch
Datum:	16.09.2016	Anlage:	Ort:	=	Blatt:	19

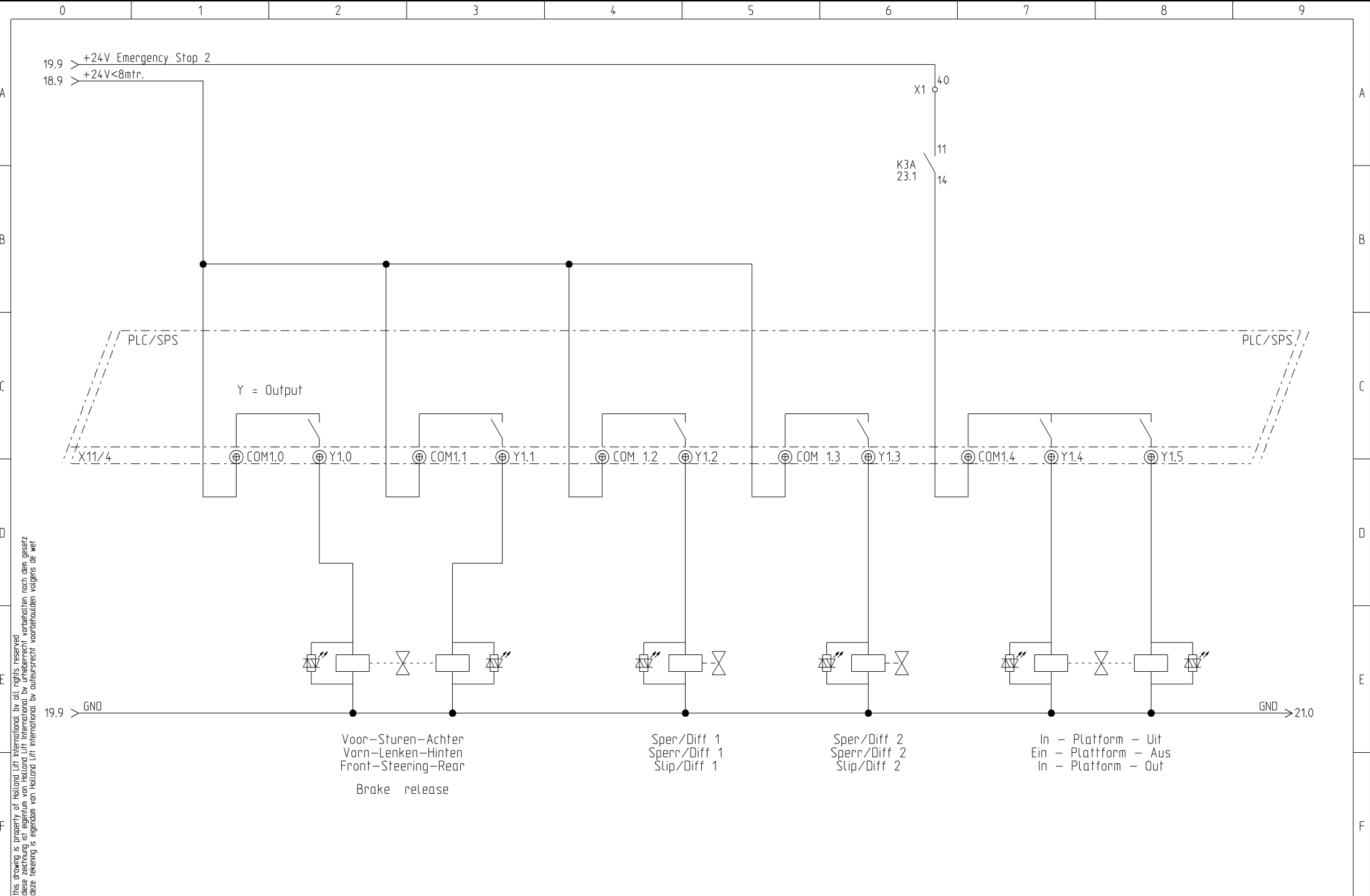

this drawing is property of Holland Lift International, by all rights reserved
 deze tekening is eigendom van Holland Lift International, by auteursrecht voorbehouden volgens de wet
 this drawing is property of Holland Lift International, by all rights reserved
 deze tekening is eigendom van Holland Lift International, by auteursrecht voorbehouden volgens de wet



Holland Lift International B.V.
 Anodeweg 1
 NL-1627 LJ Hoorn The Netherlands
 T/F +31 (0)229-285555 / 285550
 E service@hollandlift.com
 W www.hollandlift.com

STROOMKRINGSCHEMA
 STROMLAUFPLAN
 CIRCUIT DIAGRAM

Projekt:	EG-21-001	Zeichnungsnummer:	Rev.:	A	erstellt von:	Rothenbusch
Datum:	16.09.2016	Anlage:	Ort:	=	Blatt:	20

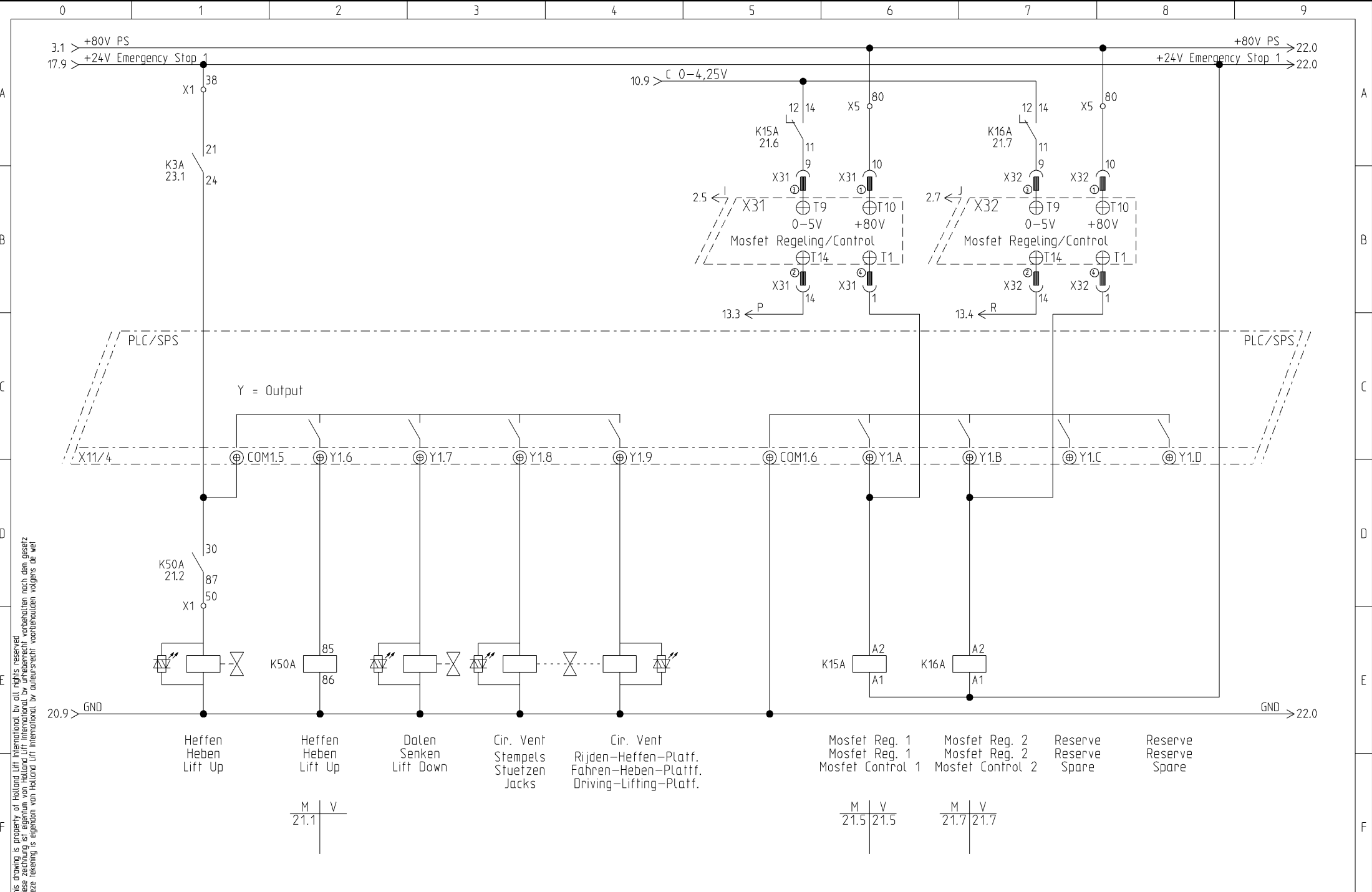

this drawing is property of Holland Lift International, by all rights reserved.
 deze tekening is eigendom van Holland Lift International, by all rights reserved.
 deze tekening is eigendom van Holland Lift International, by all rights reserved.



Holland Lift International B.V.
 Anodeweg 1
 NL-1627 LJ Hoorn The Netherlands
 T/F +31 (0)229-285555 / 285550
 E service@hollandlift.com
 W www.hollandlift.com

STROOMKINGSCHEMA
 STROMLAUFPLAN
 CIRCUIT DIAGRAM

Projekt:	EG-21-001	Zeichnungsnummer:	Rev.:	A	erstellt von:	Rothenbusch
Datum:	16.09.2016	Anlage:	Ort:	=	Blatt:	21

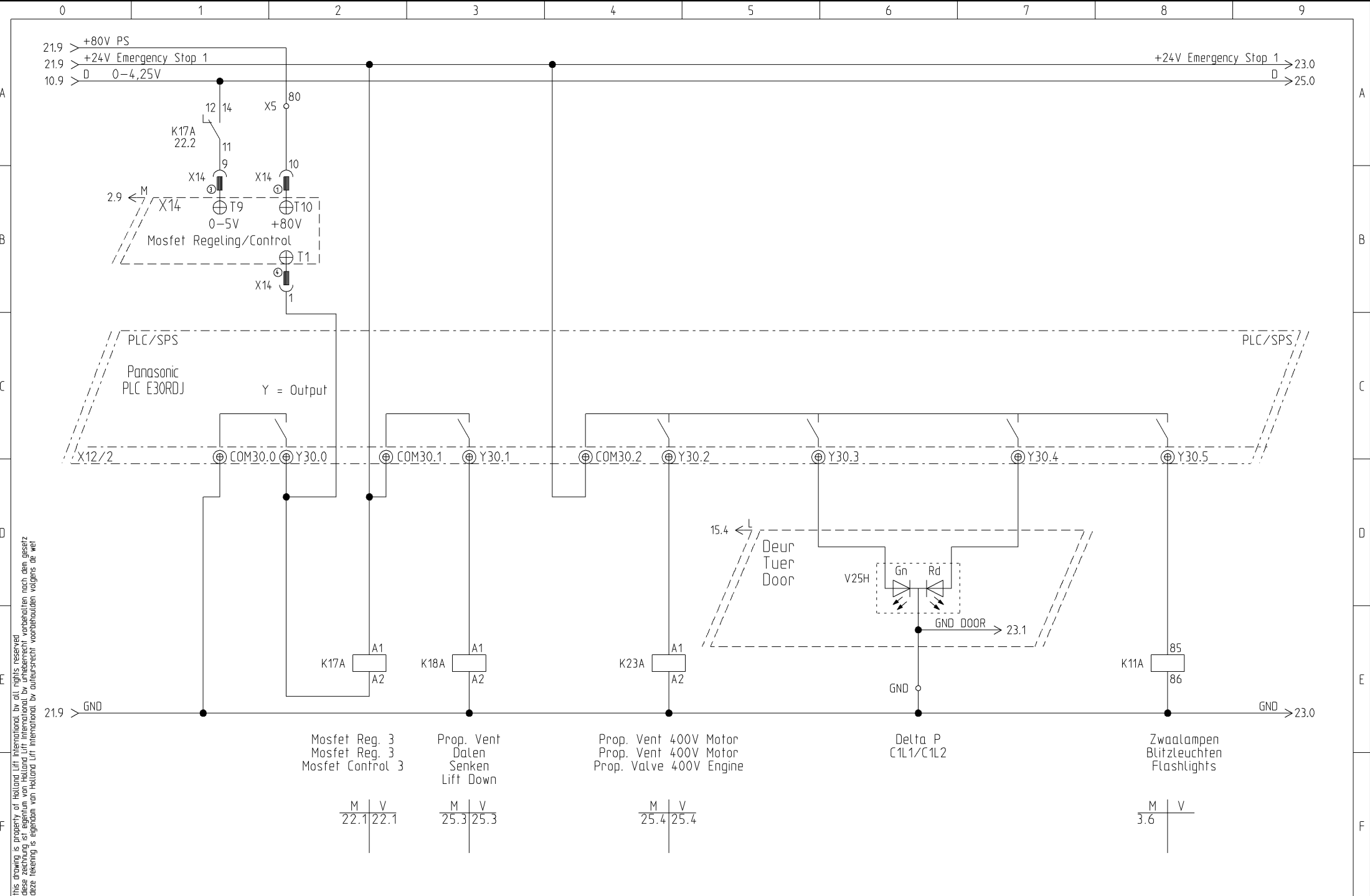

this drawing is property of Holland Lift International, by all rights reserved
 deze tekening is eigendom van Holland Lift International, by all rights reserved
 deze tekening is eigendom van Holland Lift International, by all rights reserved

this drawing is property of Holland Lift International, by all rights reserved.
 diese zeichnung ist eigentum von Holland Lift International, by urheberrecht vorbehalten nach dem gesetz.
 deze tekening is eigendom van Holland Lift International, by auteursrecht voorbehouden volgens de wet.

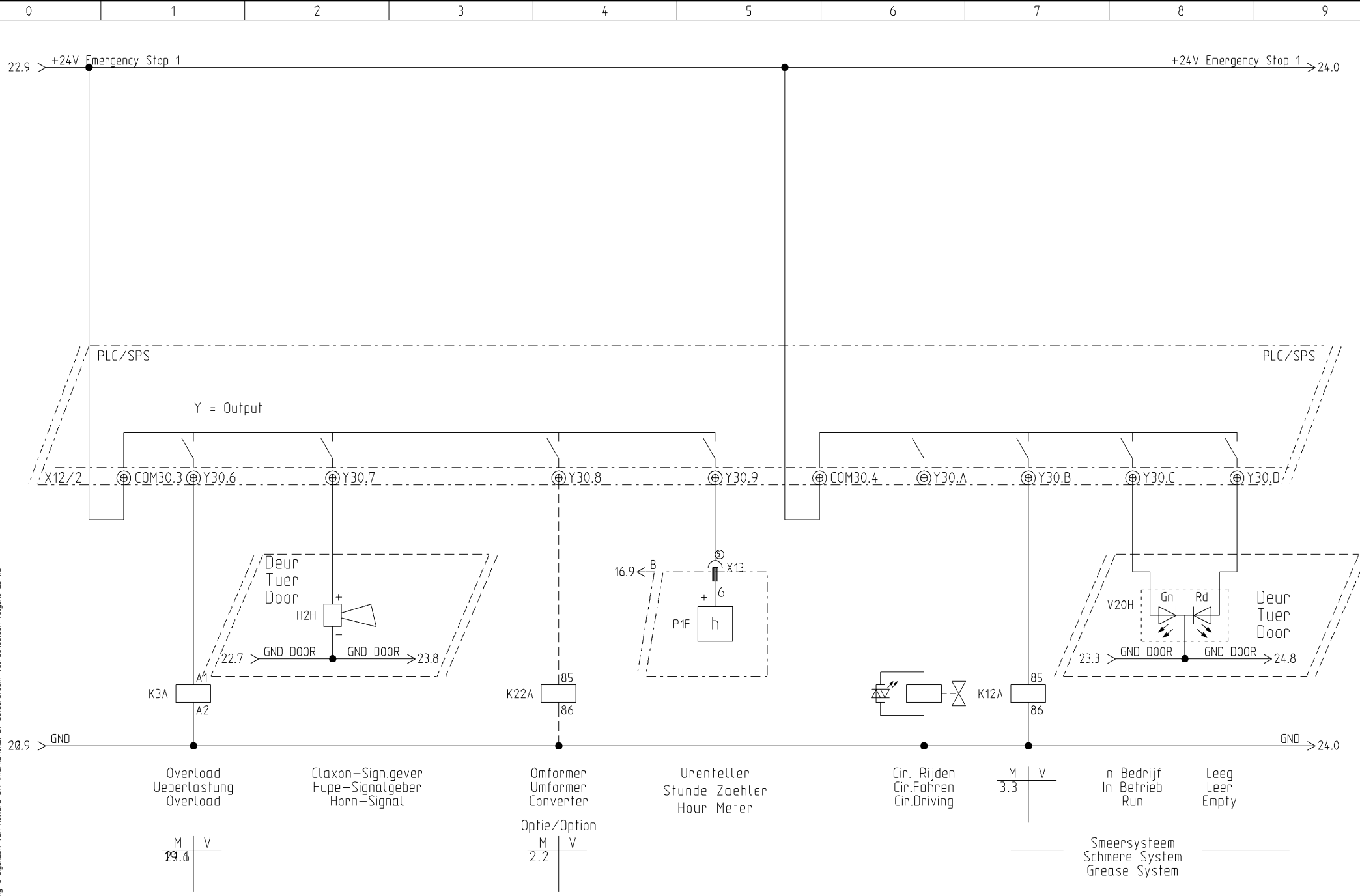

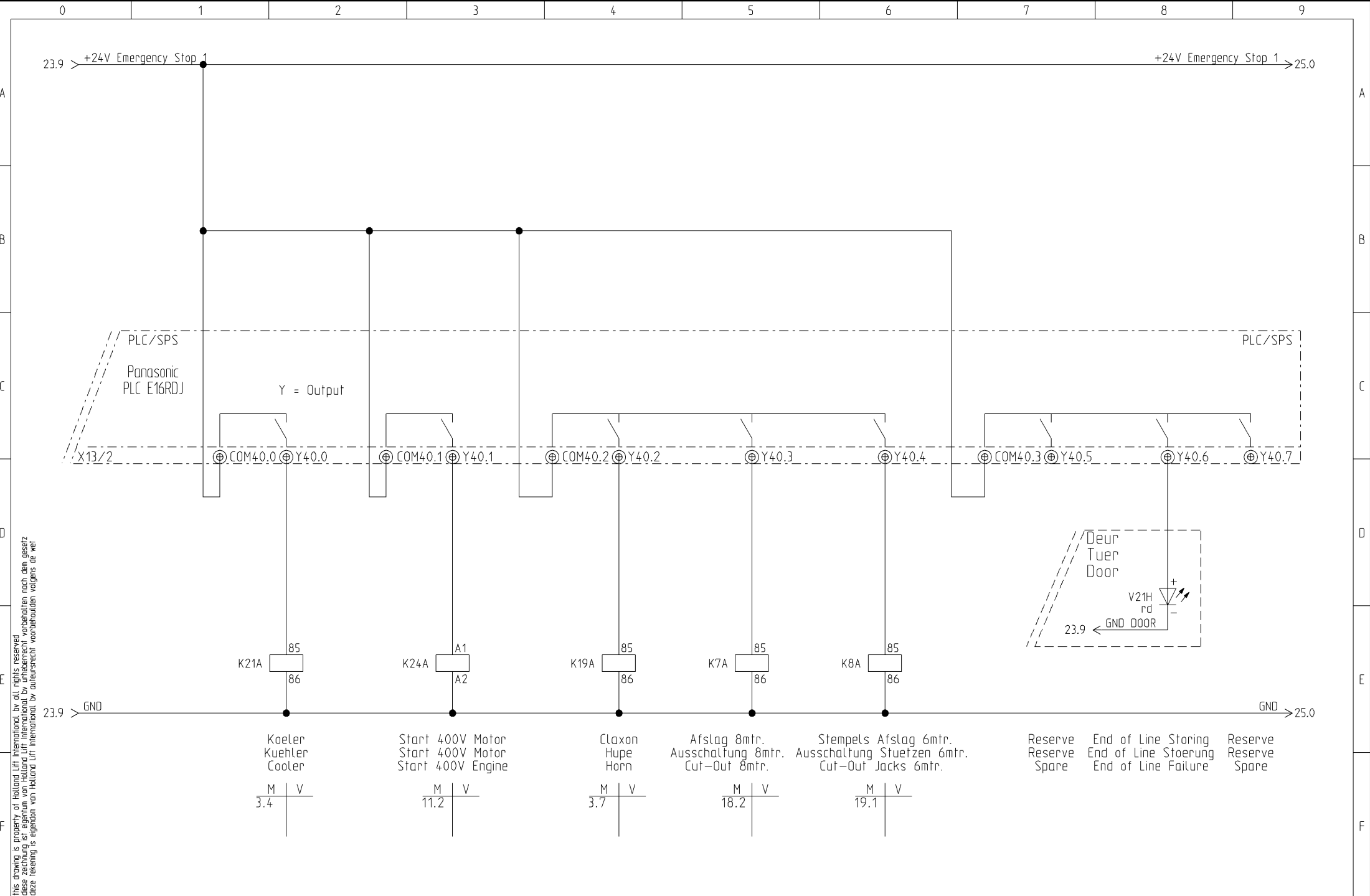

this drawing is property of Holland Lift International. By all rights reserved.
 deze tekening is eigendom van Holland Lift International. By auteursrecht voorbehouden volgens de wet.
 deze tekening is eigendom van Holland Lift International. By auteursrecht voorbehouden volgens de wet.

24.9 > +24V Emergency Stop 1
 22.9 > 0

0-4,25V

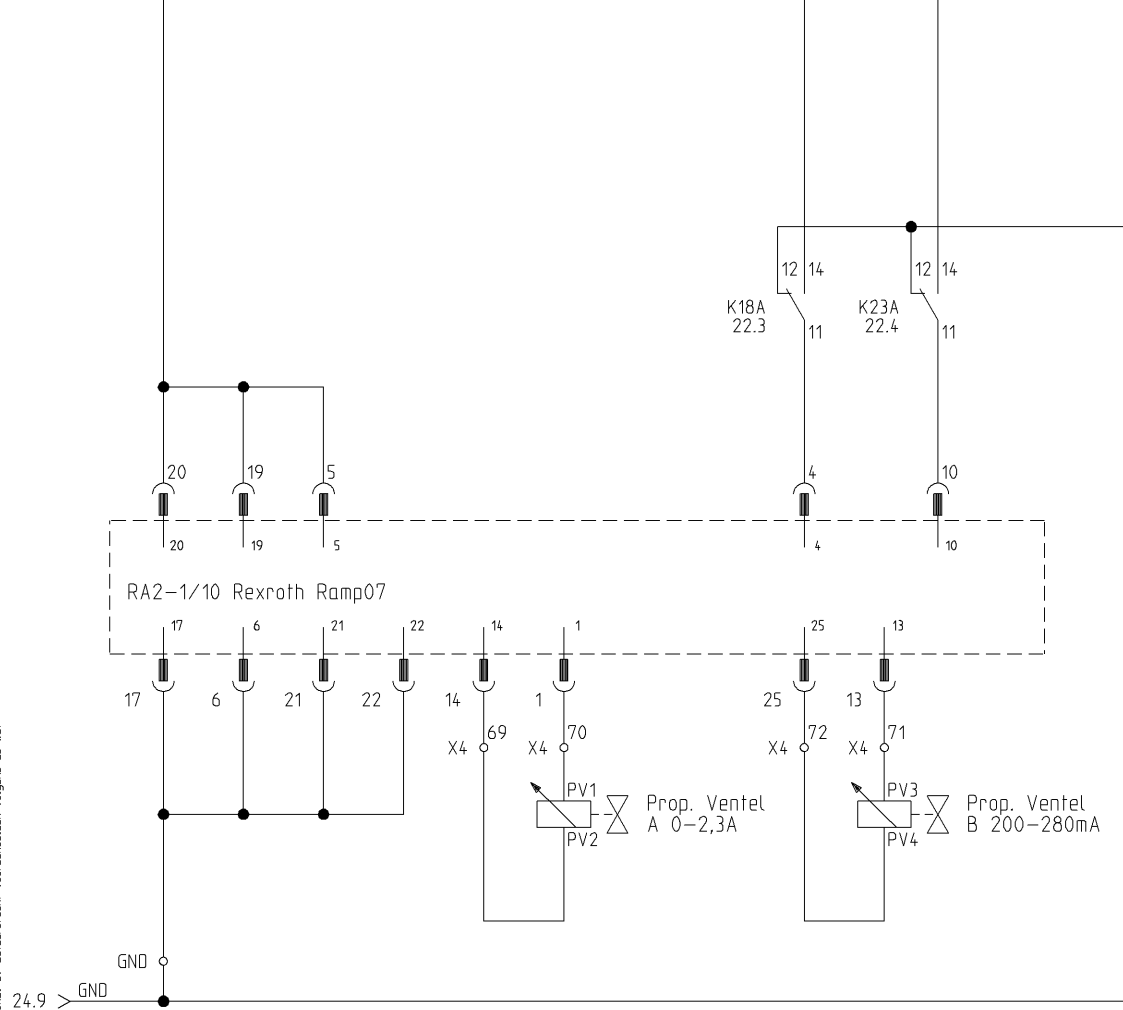

Dalen
 Senken
 Liff Down

Prop. Vent 400V Motor
 Prop. Vent 400V Motor
 Prop. Valve 400V Engine

this drawing is property of Holland Lift International. By all rights reserved.
 deze tekening is eigendom van Holland Lift International. By auteursrecht voorbehouden na dem gesatz
 deze tekening is eigendom van Holland Lift International. By auteursrecht voorbehouden volgens de wet



Holland Lift International B.V.
 Anodeweg 1
 NL-1627 LJ Hoorn The Netherlands
 T/F +31 (0)229-285555 / 285550
 E service@hollandlift.com
 W www.hollandlift.com

STROOMKRINGSHEMA
 STROMLAUFPLAN
 CIRCUIT DIAGRAM

Projekt:	EG-21-001	Zeichnungsnummer:	Rev.:	A	erstellt von:	Rothenbusch	
Datum:	16.09.2016	Anlage:	=	Ort:	+	Blatt:	25

OPTIES
OPTIONEN
OPTIONS

230V AANSLUITING PLATFORM
230V ANSCHLUSS PLATTFORM
230V SUPPLY PLATFORM

<230VPLF>

230V-50Hz/115V-50Hz

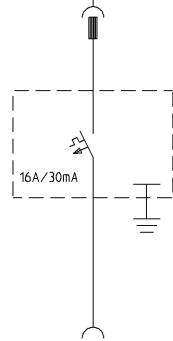

AARDLEKAUTOMAAT
FI SCHALTER
EARTH DETECTOR

OPTIE BLACK-BOX MINI DAT (HLI)			
OPTION BLACK-BOX MINI DAT			
OPTION BLACK-BOX MINI DAT			
BB-wt	+24V DC	+24V DC	+24V DC
BB-bn	GND	GND	GND
BB-gl	CH1	IN BEDRIJF	IN BETRIEB
BB-gs	CH2	MOTOR	MOTOR
BB-rs	CH3	HEFFEN	HEBEN
BB-bl	CH4	RIJDEN	FAHREN
BB-rd	CH5	LAADTIJD	LADEZEIT
			+24V DC
			GND
			RUNNING
			MOTOR
			LIFT UP
			DRIVING
			CHARGE TIME

this drawing is property of Holland Lift International, by all rights reserved
 diese zeichnung ist eigentum von Holland Lift International, by urheberrecht vorbehalten nach dem gesetz
 deze tekening is eigendom van Holland Lift International, by auteursrecht voorbehouden volgens de wet

this drawing is property of Holland Lift International, by all rights reserved
 deze tekening is eigendom van Holland Lift International, by all rights reserved
 deze tekening is eigendom van Holland Lift International, by all rights reserved

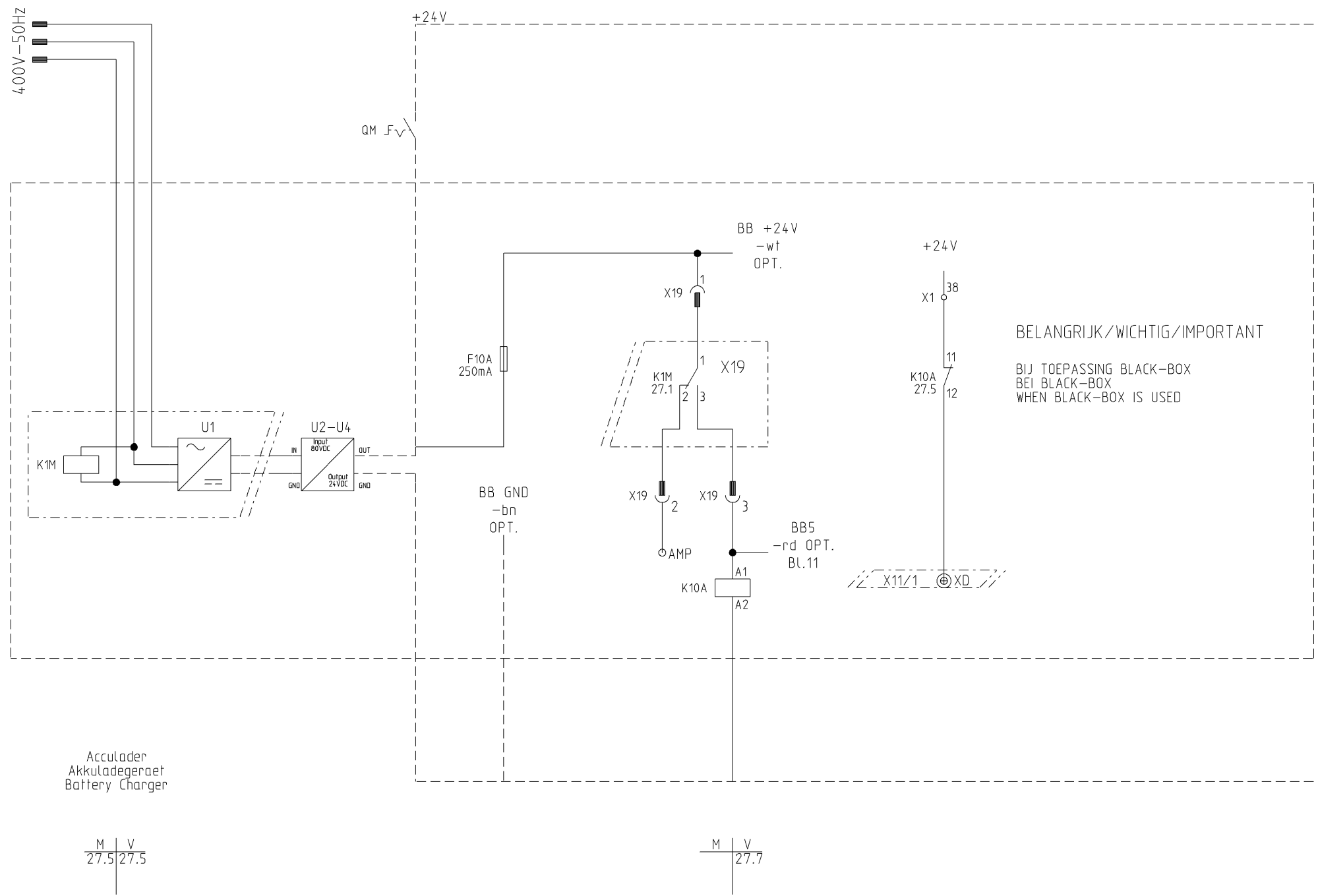

Acculader
Akkuladegeraet
Battery Charger

M | V
27.5 | 27.5

M | V
27.7

KLEMMENKAST KLEMMENKASTEN CONNECTION BOX

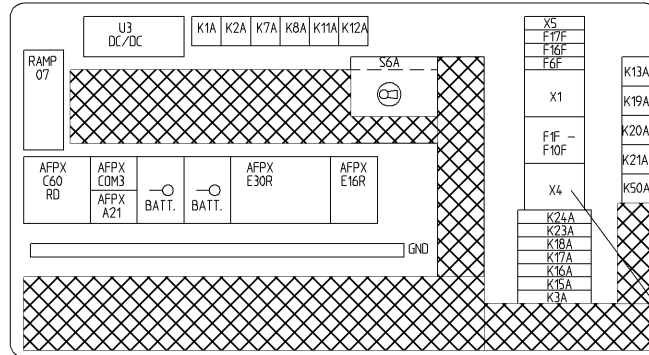

Zie Blz 30
S. Blatt 30
See Page 30

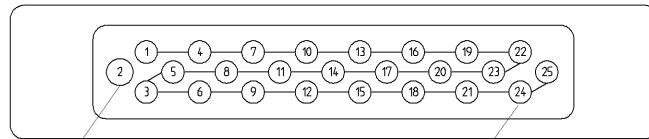

2 M25

1/3-25 M20

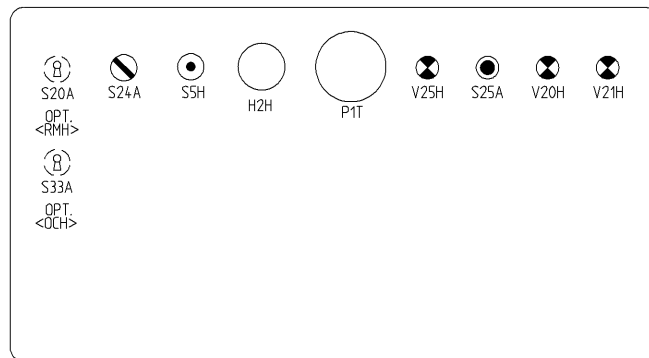

Colour schedule			
Colour	Dutch	English	Deutsch
Rd	Rood	Red	Rot
Bl	Blauw	Blue	Blau
Gl	Geel	Yellow	Gelb
Gn	Groen	Green	Grün
Zw	Zwart	Black	Schwarz
Wt	Wit	White	Weiss
Bn	Bruin	Brown	Braun
Rs	Roze	Pink	Rosa
Or	Oranje	Orange	Orange
Ps	Paars	Violet	Violett
Tp	Transp.	Transp.	Transp.
Gs	Grijs	Grey	Grau

AANSLUITING OP PLATFORM
ANSCHLUSS AUF PLATTFORM
CONNECTION ON PLATFORM

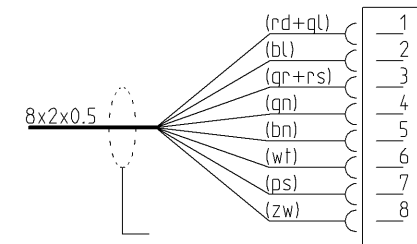

Afsterming
niet aansluiten
(aftapen)

this drawing is property of Holland Lift International, by all rights reserved
 deze tekening is eigendom van Holland Lift International, by auteursrecht voorbehouden volgens de wet
 deze tekening is eigendom van Holland Lift International, by auteursrecht voorbehouden volgens de wet

KLEMMENKAST KLEMMENKASTEN CONNECTION BOX

WARTEL KABELINF. GLAND NR.	KLEM KLEMMEN TERMINAL NR	FUNKTIE	FUNKTION	FUNCTION
1	DIV/VAR	Aanstl. 10P Platform	Anschl. 10P Plattform	Conn. 10P Platform
2	DIV/VAR	Lasdoos voor	Verteilerdose vorn	Connection Box front
3	DIV/VAR	Lasd. Cyl1/ Cyl2/Plf	Vert. Cyl1/ Cyl2/Plf	Conn. Cyl1/ Cyl2/Plf
4	DIV/VAR	Smeersytem	Schmiere System	Grease System
5.1	Y0-GND	Rijden Vooruit	Fahren Vorwaerts	Driving Forward
5.2	Y1-GND	Rijden Achteruit	Fahren Rueckwaerts	Driving Reverse
6.1	Y2-GND	Sturen Links Voor	Lenken Links Vorn	Steering Left Front
6.2	Y3-GND	Sturen Rechts Voor	Lenken Rechts Vorn	Steering Right Front
7.1	Y4-GND	Sturen Links Achter	Lenken Links Hinten	Steering Left Rear
7.2	Y5-GND	Sturen Rechts Achter	Lenken Rechts Hinten	Steering Right Rear
8.1	Y1.0-GND	Ontlast. Sturen Voor	Entlast. Lenken Vorn	Reliese Steering Front
8.2	Y1.1-GND	Ontlast. Sturen Achter	Entlast. Lenken Hinten	Reliese Steering Rear
9.1	Y1.2-GND	Sper/Diff. Ventiel	Sperr/Diff. Ventil	Slip/Diff. Valve
9.2	Y1.3-GND	Sper/Diff. Ventiel	Sperr/Diff. Ventil	Slip/Diff. Valve
10.1	Y1.9-GND	Cir. Vent Ri.-He.-Pl.	Cir. Vent. Fa.-He.-Pl.	Cir. Valve Dr.-L.-Pl.
10.2	Y30.A-GND	Cir. Ventiel Rijden	Cir. Ventil Fahren	Cir. Valve Diving
10.3	Y1.8-GND	Cir. Ventiel Stempels	Cir. Ventil Stuetzen	Cir. Valve Jacks
11.1	φ 40 - φ 42	Hoofdschakelaar	Hauptschalter	Main Switch
11.2	φ 42-GND	Hoofdcontactgever	Hauptschuetz	Main contactor
11.3	φ 68-GND	Koeler	Kuehler	Cooler
12.1	φ 38-GND-X4	Scheefstand	Neigung	Inclination
12.2	φ 38-GND-X5	Scheefstand Opt.	Neigung Opt.	Inclination Opt.
12.3	DIV/VAR	Auto Niv.	Auto Niv.	Auto Niv.
13.1	φ 50-GND	Heffen	Heben	Lift Up
13.2	Y1.7-GND	Dalen	Senken	Lift Down
14.1	Y1.4-GND	Platform in	Plattform ein	Platform in
14.2	Y1.5-GND	Platform uit	Plattform aus	Platform out
15.1	Y6-GND	Stempels LV in	Stuetzen LV ein	Jacks LF in
15.2	Y7-GND	Stempels LV uit	Stuetzen LV aus	Jacks LF out
16.1	Y8-GND	Stempels RV in	Stuetzen RV ein	Jacks RF in
16.2	Y9-GND	Stempels RV uit	Stuetzen RV aus	Jacks RF out
17.1	YC-GND	Stempels RA in	Stuetzen RH ein	Jacks RR in
17.2	YD-GND	Stempels RA uit	Stuetzen RH aus	Jacks RR out
18.1	YA-GND	Stempels LA in	Stuetzen LH ein	Jacks LR in
18.2	YB-GND	Stempels LA uit	Stuetzen LH aus	Jacks LR out
19	DIV/VAR	Lasdoos achter	Verteilerdose hinten	Connection Box rear

WARTEL KABELINF. GLAND NR.	KLEM KLEMMEN TERMINAL NR	FUNKTIE	FUNKTION	FUNCTION
20.1 & .2	φ 1	+24V Omvormer	+24V Wandler	+24V Converter
20.3 & .4	AMP	+80V Omvormer	+80V Wandler	+80V Converter
20.5 - .8	GND	GND Omvormer	GND Wandler	GND Converter
21.1	φ 66 -GND	Claxon	Horn	Horn
21.2	φ 70 - φ 69	Prop. Ventiel Dalen	Prop. Ventil Senken	Prop. Valve Lift Down
21.3	φ 72 - φ 71	Prop. Ventiel 400V	Prop. Ventil 400V	Prop. Valve 400V
22.1	DIV/VAR	Motorregeling 1	Motorregelung 1	Motor Control 1
22.2	DIV/VAR	Motorregeling 2	Motorregelung 2	Motor Control 2
22.3	DIV/VAR	Motorregeling 3	Motorregelung 3	Motor Control 3
23.1	AMP	Voeding +80V	Speisung +80V	Power Supply +80V
23.2	GND	Voeding GND	Speisung GND	Power Supply GND
23.3	φ 38 -XD-RES	Acculader	Akkuladegeraet	Battery Charger
24.1	DIV/VAR	Accumeter	Akkumeter	Batterymeter
24.2	φ 38 -X40.4	Temp. 45°	Temp. 45°	Temp. 45°
24.3	φ 38 -X40.5	Temp. 85°	Temp. 85°	Temp. 85°
25	DIV/VAR	Kast El. Motor	Kasten El. Motor	Box El. Engine

this drawing is property of Holland Lift International, by all rights reserved
 diese zeichnung ist eigentum von Holland Lift International, by alle rechte vorbehalten
 deze tekening is eigendom van Holland Lift International, by auteursrecht voorbehouden volgens de wet

HOLLAND LIFT

Holland Lift International B.V.
 Anodeweg 1
 NL-1627 LJ Hoorn The Netherlands
 T/F +31 (0)229-285555 / 285550
 E service@hollandlift.com
 W www.hollandlift.com

KASTEN/BEKABELING
 KASTEN/KABEL
 BOXES/CABLES

Projekt:	EG-21-001	Zeichnungsnummer:	Rev.:	A	erstellt von:	Rothenbusch	
Datum:	16.09.2016	Antage:	=	Ort:	+	Blatt:	29

KLEMMENKAST
KLEMMENKASTEN
CONNECTION BOX

X5	80	80	80	80
		F17F	10A	
		F16F	10A	
		F6F	5A	
	42			42
	40	50	50	40
	39	39	39	39
	38	38	38	38
	38	38	38	38
	38	38	38	38
	38	38	38	38
	37	37	37	37
	33	36	36	33
X1	32	35	35	32
	31	34	34	31
		F10F	10A	
		F9F	7.5A	
		F8F	7.5A	
		F7F	7.5A	
		F5F	5A	
		F4F	5A	
		F3F	5A	
		F2F	20A	
		F1F	20A	
	67	72	72	67
	66	71	71	66
	65	70	70	65
	64	69	69	64
	63	68	68	63
X4		1		1

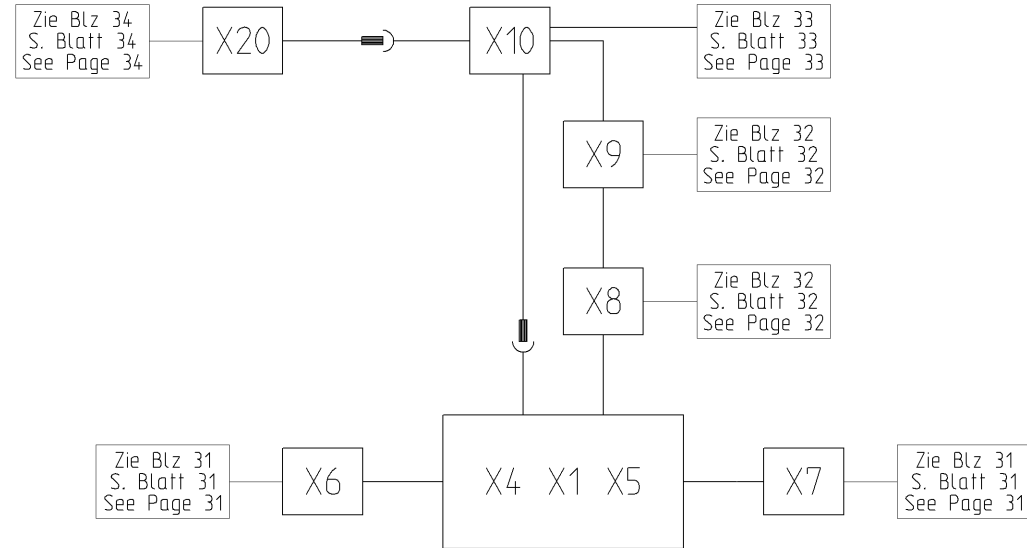

this drawing is property of Holland Lift International, by all rights reserved
 deze tekening is eigendom van Holland Lift International, by auteursrecht voorbehouden volgens de wet
 deze tekening is eigendom van Holland Lift International, by auteursrecht voorbehouden volgens de wet

LASDOOS AFSLAGEN
VERTEILERDOSE HOEHEAUSSCHALTUNG
MAXIMUM HEIGHT DISTRIBUTOR BOX

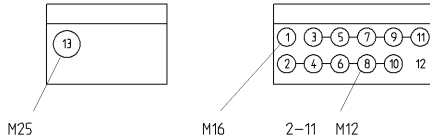
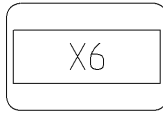

X6

101	101	101	101	102	103	104	105		106	107	108	109	110	111	112	113	113	114	115	116	117	118	119
+	+	+	+													-	-	-				-	

F5F

LASDOOS ACHTER
VERTEILERDOSE HINTEN
DISTRBUOR BOX REAR

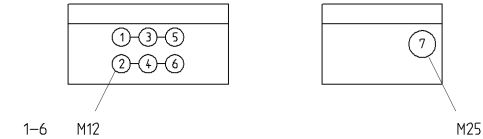
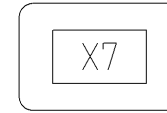

X7

171	171	172	173	174	175	175	175	176	177	178	179	180												
+	+	+											-	-	-									-

F5F

NR.	Omschrijving	Beschreibung	Descrption
1	5,5mtr. Afslag S1Q	5,5mtr. Ausschaltung S1Q	5,5mtr. Cut-out S1Q
2	8mtr. Afslag S2Q	8mtr. Ausschaltung S2Q	8mtr. Cut-out S2Q
3	Stempels Afslag S19Q	Stuetzen Ausschaltung S19Q	Jacks Cut-out S19Q
4	29mtr. Afslag S4Q	29mtr. Ausschaltung S4Q	29mtr. Cut-out S4Q
5	Max. Hooqte Afslag S3Q	Max. Hoehe Ausschaltung S3Q	Max. Height Cut-out S3Q
6	Eindschak. Vooras Recht S17Q	Endschalter vorn Achse S17Q	Limit Switch AxLe front S17Q
7	Eindschak. LV in S9Q	Endschalter LV ein S9Q	Limit Switch LF in S9Q
8	Eindschak. LV uit S13Q	Endschalter LV aus S13Q	Limit Switch LF out S13Q
9	Eindschak. RV in S10Q	Endschalter RV ein S10Q	Limit Switch RF in S10Q
10	Eindschak. RV uit S14Q	Endschalter RV aus S14Q	Limit Switch RF out S14Q
11	Zwaailamp voor	Blitzleuchte vorn	Flashlight front
12	Res.	Res.	Spare
13	Kabel Klemmenkast	Kabel Klemmenkasten	Cable Connection Box

NR.	Omschrijving	Beschreibung	Descrption
1	Eindschak. LA in S11Q	Endschalter LA ein S11A	Limit Switch LR in S11Q
2	Eindschak. LA uit S15Q	Endschalter LA aus S15Q	Limit Switch LR out S15Q
3	Eindschak. RA in S12Q	Endschalter RA ein S12Q	Limit Switch RR in S12Q
4	Eindschak. RA uit S16Q	Endschalter RA aus S16Q	Limit Switch RR out S16Q
5	Eindschak. Achteras Recht S18Q	Endschalter hinten Achse S18Q	Limit Switch AxLe rear S18Q
6	Zwaailamp achter	Blitzleuchte hinten	Flashlight rear
7	Kabel Klemmenkast	Kabel Klemmenkasten	Cable Connection Box

KAST CYLINDER LAAG (1)
 KASTEN ZYLINDER NIEDRIG (1)
 CYLINDER BOX LOW (1)

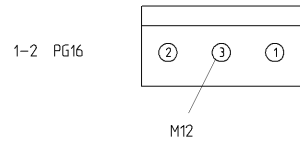
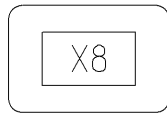

X8

	+	+					+			+				-
	141	141	142	143	AFS	AFS	144	145	146	147	148	149	150	

NR.	Omschrijving	Beschreibung	Description
1	Kabel Klemmenkast	Kabel Klemmenkasten	Cable Connection Box
2	Cyl. 2 hoog	Zyl. 2 hoch	Cly. 2 high
3	Druksensor Cyl. 1 (4-20mA)	Drucksensor Zyl. 1 (4-20mA)	Press. Sensor Cyl. 1 (4-20mA)

KAST CYLINDER HOOG (2)
 KASTEN ZYLINDER HOCH (2)
 CYLINDER BOX HIGH (2)

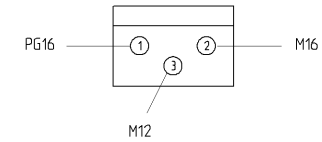
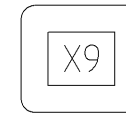
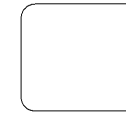

X9

	+		+		+		-			
	151	153	AFS	154	155	156	157	158	159	160

NR.	Omschrijving	Beschreibung	Description
1	Cyl. 1 laag	Zyl. 1 niedrig	Cly. 1 low
2	Lasdoos Platform	Verteilerdose Plattform	Connection Box Platform
3	Druksensor Cyl. 2 (4-20mA)	Drucksensor Zyl. 2 (4-20mA)	Press. Sensor Cyl. 2 (4-20mA)

this drawing is property of Holland Lift International, by all rights reserved.
 diese zeichnung ist Eigentum von Holland Lift International, by alle rechte vorbehalten nach dem gesetz
 deze tekening is eigendom van Holland Lift International, by auteursrecht voorbehouden volgens de wet

HOLLAND LIFT

Holland Lift International B.V.
 Anodeweg 1
 NL-1627 LJ Hoorn The Netherlands
 T/F +31 (0)229-285555 / 285550
 E service@hollandlift.com
 W www.hollandlift.com

KASTEN/BEKABELING
 KASTEN/KABEL
 BOXES/CABLES

Projekt:	EG-21-001	Zeichnungsnummer:	Rev.:	A	erstellt von:	Rothenbusch	
Datum:	16.09.2016	Antage:	=	Ort:	+	Blatt:	32

LASDOOS PLATFORM
 VERTEILERDOSE PLATFORM
 PLATFORM DISTRBUOR BOX

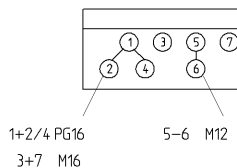
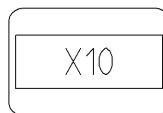

X10

+	-								+	-					+	-		
121	122	123	124	125	126	127	128	129	130	AFS	194	194	195	196	197	198	199	200

NR.	Omschrijving	Beschreibung	Descreption
1	Kabel Klemmenkast	Kabel Klemmenkasten	Cable Connection Box
2	Cyl. 2 hoog	Zyl. 2 hoch	Cly. 2 high
3	WCD voor	Verteilerdose vorn	Connection Box front
4	WCD achter	Verteilerdose hinten	Connection Box rear
5	Eindschak. Platform in S5Q	Endschalter Plattform ein S5Q	Limit Switch Platform in S5Q
6	Eindschak. Overload S7Q	Endschalter Ueberlast S7Q	Limit Switch Overload S7Q
7	Drukschak. Smeersyst. (Opt.)	Druckschaltf. Schmiersyst. (Opt.)	Press. Swit. Grease Syst. (Opt.)

this drawing is property of Holland Lift International, by all rights reserved
 deze tekening is eigendom van Holland Lift International, by auteursrecht voorbehouden volgens de wet
 deze tekening is eigendom van Holland Lift International, by auteursrecht voorbehouden volgens de wet

BEDIENINGSKAST STEUERPULT CONTROL BOX

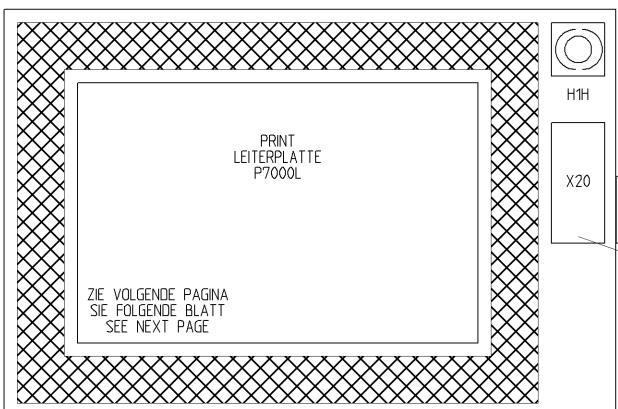
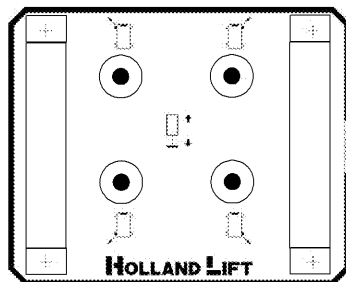
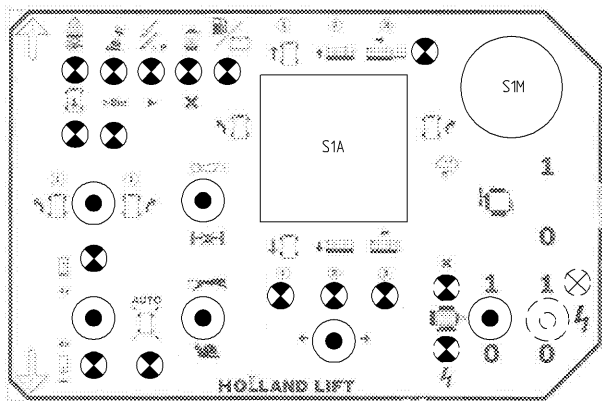

Colour schedule			
Colour	Dutch	English	Deutsch
Rd	Rood	Red	Rot
Bl	Blauw	Blue	Blau
Gl	Geel	Yellow	Gelb
Gn	Groen	Green	Gruen
Zw	Zwart	Black	Schwarz
Wt	Wit	White	Weiss
Bn	Bruin	Brown	Braun
Rs	Roze	Pink	Rosa
Or	Oranje	Orange	Orange
Ps	Paars	Violet	Violett
Tp	Transp.	Transp.	Transp.
Gs	Grijs	Grey	Grau

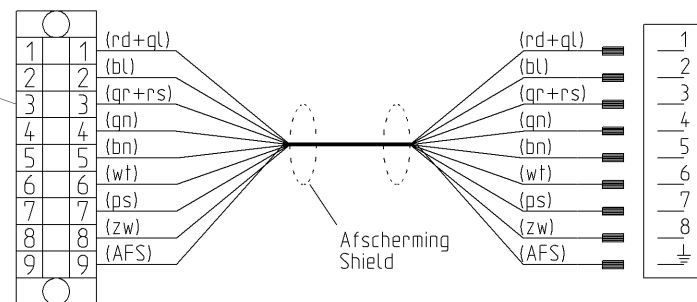
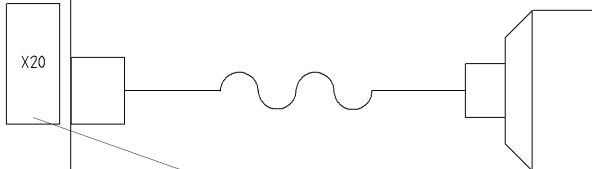

this drawing is property of Holland Lift International, by all rights reserved.
 deze tekening is eigendom van Holland Lift International, by auteursrecht voorbehouden volgens de wet

HOLLAND LIFT

Holland Lift International B.V.
 Anodeweg 1
 NL-1627 LJ Hoorn The Netherlands
 T/F +31 (0)229-285555 / 285550
 E service@hollandlift.com
 W www.hollandlift.com

KASTEN/BEKABELING
 KASTEN/KABEL
 BOXES/CABLES

Projekt: EG-21-001

Zeichnungsnummer:

Rev.: A

erstellt von:
 Rothenbusch

Datum: 16.09.2016

Anlage: =

Ort: +

Blatt: 34

PRINTPLAAT
LEITERPLATTE
CIRCUIT BOARD

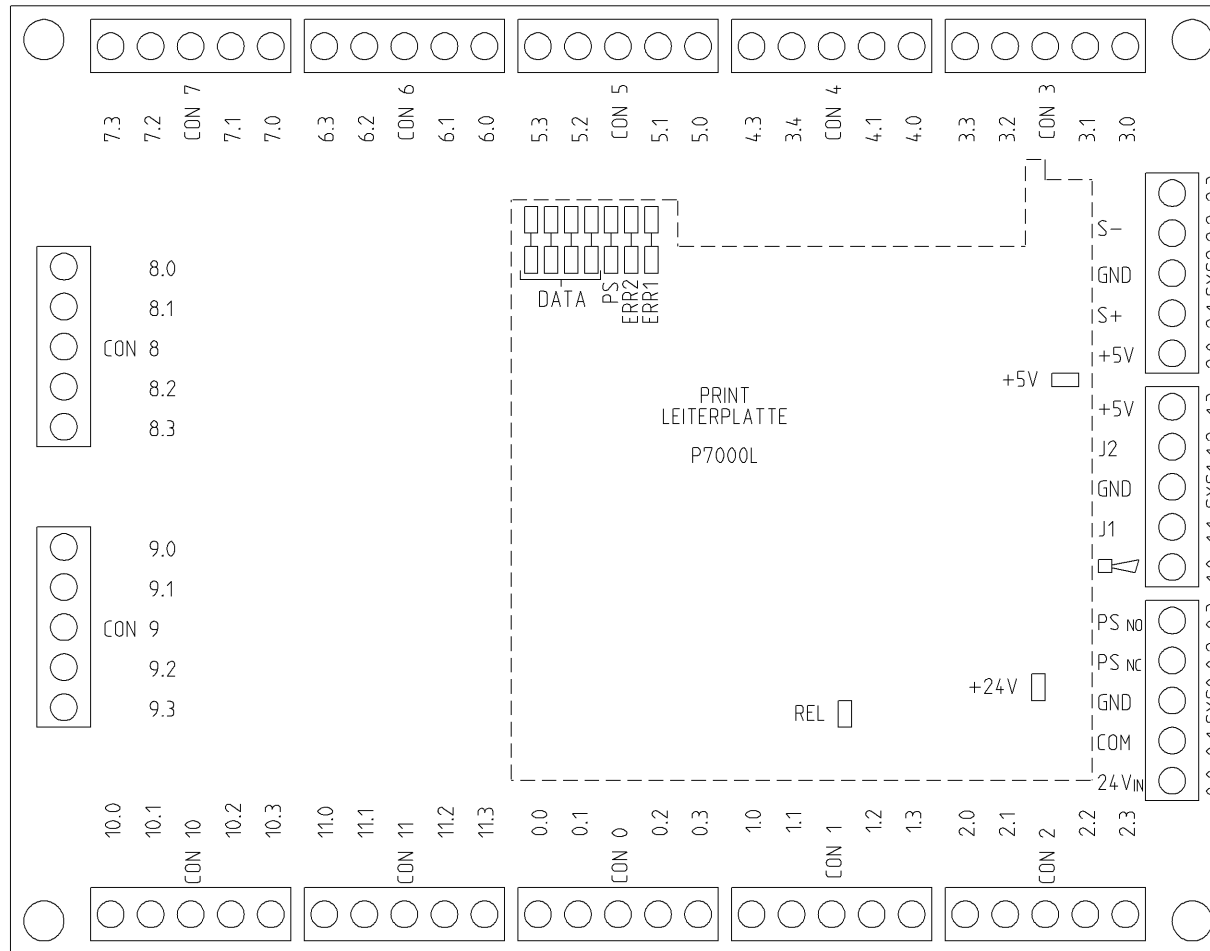

+24V	<input type="checkbox"/>	Groen/Gruen/Green	Voeding Ok	Speisung Ok	Supply Ok
+5V	<input type="checkbox"/>	Groen/Gruen/Green	Voeding Ok	Speisung Ok	Supply Ok
REL	<input type="checkbox"/>	Groen/Gruen/Green	Power Safe aan	Power Safe an	Power Safe on
PS	<input type="checkbox"/>	Geel/Gelb/Yellow	Power Safe uit	Power Safe aus	Power Safe off
Err1	<input type="checkbox"/>	Geel/Gelb/Yellow	Slechte Data Verbinding	Schlechte Data Verbindung	Poor Data Connection
Err2	<input type="checkbox"/>	Rood/Rot/Red	Geen Data Verbinding	Keine Data Verbindung	No Data Connection

this drawing is property of Holland Lift International, by all rights reserved.
 diese zeichnung ist eigentum von Holland Lift International, by urheberrecht vorbehalten nach dem gesetz.
 deze tekening is eigendom van Holland Lift International, by auteursrecht voorbehouden volgens de wet.

HOLLAND LIFT

Holland Lift International B.V.
 Anodeweg 1
 NL-1627 LJ Hoorn The Netherlands
 T/F +31 (0)229-285555 / 285550
 E service@hollandlift.com
 W www.hollandlift.com

PRINTPLAAT
LEITERPLATTE
CIRCUIT BOARD

Projekt: EG-21-001

Zeichnungsnummer:

Rev.: A

erstellt von:
Rothenbusch

Datum: 16.09.2016

Anlage:

Ort:

Blatt: 35

this drawing is property of Holland Lift International, by all rights reserved
 deze tekening is eigendom van Holland Lift International, by auteursrecht voorbehouden volgens de wet
 deze tekening is eigendom van Holland Lift International, by auteursrecht voorbehouden volgens de wet

0.0	Joystick Op (S1A2)	Fahren Joy. Auf (S1A2)	Joystick On (S1A2)
0.1	Joystick Neer (S1A3)	Fahren Joy. Nied. (S1A3)	Joystick Down (S1A3)
CON 0			
0.2	Sturen Links (S1A4)	Lenken Links (S1A4)	Steering Left (S1A4)
0.3	Sturen Rechts (S1A5)	Lenken Rechts (S1A5)	Steering Right (S1A5)

1.0	Claxon (S2A1)	Hupe (S2A1)	Horn (S2A1)
1.1	Sper/Diff. (S2A2)	Sperr/Diff. (S2A2)	Slip/Diff. (S2A2)
CON 1			
1.2	Hef./Rij./Pla. (S3A1)	Heb./Fah./Pla. (S3A1)	Lif./Dri./Pla. (S3A1)
1.3	Hef./Rij./Pla. (S3A3)	Heb./Fah./Pla. (S3A3)	Lif./Dri./Pla. (S3A3)

2.0	Snel Rijden (S4A1)	Schnell Fahren (S4A1)	Driving Fast (S4A1)
2.1	Reserve	Reserve	Spare
CON 2			
2.2	Langzaam Rij. (S4A3)	Langsam Fahren (S4A3)	Driving Slow (S4A3)
2.3	Dodemansknop (S1A1)	Totmanskноп (S1A1)	Dead Man (S1A1)

0.0	Voeding +24V (S1M)	Speisung +24V (S1M)	Supply +24V (S1M)
0.1	Voeding +24V (S1M)	Speisung +24V (S1M)	Supply +24V (S1M)
SYS0 GND	GND	GND	GND
0.2	Reserve	Reserve	Spare
0.3	Voeding +24V (PS)	Speisung +24V (PS)	Supply +24V (PS)

1.0	+ Zoemer (H1H)	+ Summer (H1H)	+ Buzzer (H1H)
1.1	0-5V Joystick P1	0-5V Joystick P1	0-5V Joystick P1
SYS1 GND	- Zoemer (H1H)	- Summer (H1H)	- Buzzer (H1H)
1.2	Reserve (0-5V)	Reserve (0-5V)	Spare (0-5V)
1.3	Voeding +5V Joy. (P1)	Speisung +5V Joy. (P1)	Supply +5V Joy. (P1)

2.0	Reserve (+5V)	Reserve (+5V)	Spare (+5V)
2.1	Data S+ (RS485)	Data S+ (RS485)	Data S+ (RS485)
SYS2 GND	Reserve	Reserve	Spare
2.2	Data S- (RS485)	Data S- (RS485)	Data S- (RS485)
2.3	Reserve	Reserve	Spare

3.0	Sturen LA (S10A1)	Lenken LH (S10A1)	Steering LR (S10A1)
3.1	Sturen RA (S10A3)	Lenken RH (S10A3)	Steering RR (S10A3)
CON 3			
3.2	4x Stempels in (S11A1)	4x Stuetzen ein (S11A1)	4x Jacks in (S11A1)
3.3	4x uit Au. Niv. (S11A3)	4x aus Au. Niv. (S11A3)	4x out Au. Niv. (S11A3)

4.0	Accu gelad. gn (V18H)	Akku gelad. gn (V18H)	Battery load. gn (V18H)
4.1			
CON 4			
4.2	Stor. 400V M. (V21H)	Stoer. 400V M. (V21H)	Fail. 400V E. (V21H)
4.3	400V aanwezig (V20H)	400V anwesend (V20H)	400V present (V20H)

5.0	Vetpomp (V7H)	Fett Pumpe (V7H)	Grease Pump (V7H)
5.1	Overload (V1H)	Ueberlastung (V1H)	Overload (V1H)
CON 5			
5.2	Scheefstand (V2H)	Neigung (V2H)	Inclination (V2H)
5.3	Accu leeg rd (V18H)	Akku leer rd (V18H)	Battery emp. rd (V18H)

6.0	Start 400V M. (S11A3)	Start 400V M. (S11A3)	Start 400V E. (S11A3)
6.1	Stop 400V M. (S11A1)	Halt 400V M. (S11A1)	Stop 400V E. (S11A1)
CON 6			
6.2	Om. aan Opt. (S18A1)	Um. an Opt. (S18A1)	Co. on Opt. (S18A1)
6.3	Om. uit Opt. (S18A3)	Um. aus Opt. (S18A3)	Co. off Opt. (S18A3)

7.0	Stempels LA in (S15A1)	Stuetzen LH ein (S15A1)	Jacks LR in (S15A1)
7.1	Stemp. LA uit (S15A3)	Stuetzen LH aus (S15A3)	Jacks LR out (S15A3)
CON 7			
7.2	Stempels RA in (S16A1)	Stuetzen RH ein (S16A1)	Jacks RR in (S16A1)
7.3	Stemp. RA uit (S16A3)	Stuetzen RH aus (S16A3)	Jacks RR out (S16A3)

8.0	Stempels LV in (S13A1)	Stuetzen LV ein (S13A1)	Jacks LF in (S13A1)
8.1	Stemp. LV uit (S13A3)	Stuetzen LV aus (S13A3)	Jacks LF out (S13A3)
CON 8			
8.2	Stempels RV in (S14A1)	Stuetzen RV ein (S14A1)	Jacks RF in (S14A1)
8.3	Stemp. RV uit (S14A3)	Stuetzen RV aus (S14A3)	Jacks RF out (S14A3)

9.0	8mtr. Afslag (V15H)	8mtr. Ausschalt. (V15H)	8mtr. Cut-out (V15H)
9.1	Stempels in (V11H)	Stuetzen ein (V11H)	Jacks in (V11H)
CON 9			
9.2	Stempels uit (V5H)	Stuetzen aus (V5H)	Jacks out (V5H)
9.3	Auto Niv. (V9H)	Auto Niv. (V9H)	Auto Niv. (V9H)

10.0	Omformer Opt. (V17H)	Umformer Opt. (V17H)	Converter Opt. (V17H)
10.1	400V run gn (V20H)	400V run gn (V20H)	400V run gn (V20H)
CON 10			
10.2	Vooras Recht (V4H)	Vorn Achse Hor. (V4H)	Axle front Hor. (V4H)
10.3	Platform uit (V6H)	Platform aus (V6H)	Platform out (V6H)

11.0	Rijden (V12H)	Fahren (V12H)	Driving (V12H)
11.1	Heffen (V13H)	Heben (V13H)	Lifting (V13H)
CON 11			
11.2	Platform (V14H)	Plattform (V14H)	Platform (V14H)
11.3	Delta P (V16H)	Delta P (V16H)	Delta P (V16H)



Holland Lift International B.V.
 Anodeweg 1
 NL-1627 LJ Hoorn The Netherlands
 T/F +31 (0)229-285555 / 285550
 E service@hollandlift.com
 W www.hollandlift.com

PRINTPLAAT
 LEITERPLATTE
 CIRCUIT BOARD

Projekt:	EG-21-001	Zeichnungsnummer:	Rev.:	A	erstellt von:	Rothenbusch	
Datum:	16.09.2016	Antage:	=	Ort:	+	Blatt:	36

EL. MOTOR 30kW
 EL. MOTOR 30kW
 EL. ENGINE 30kW

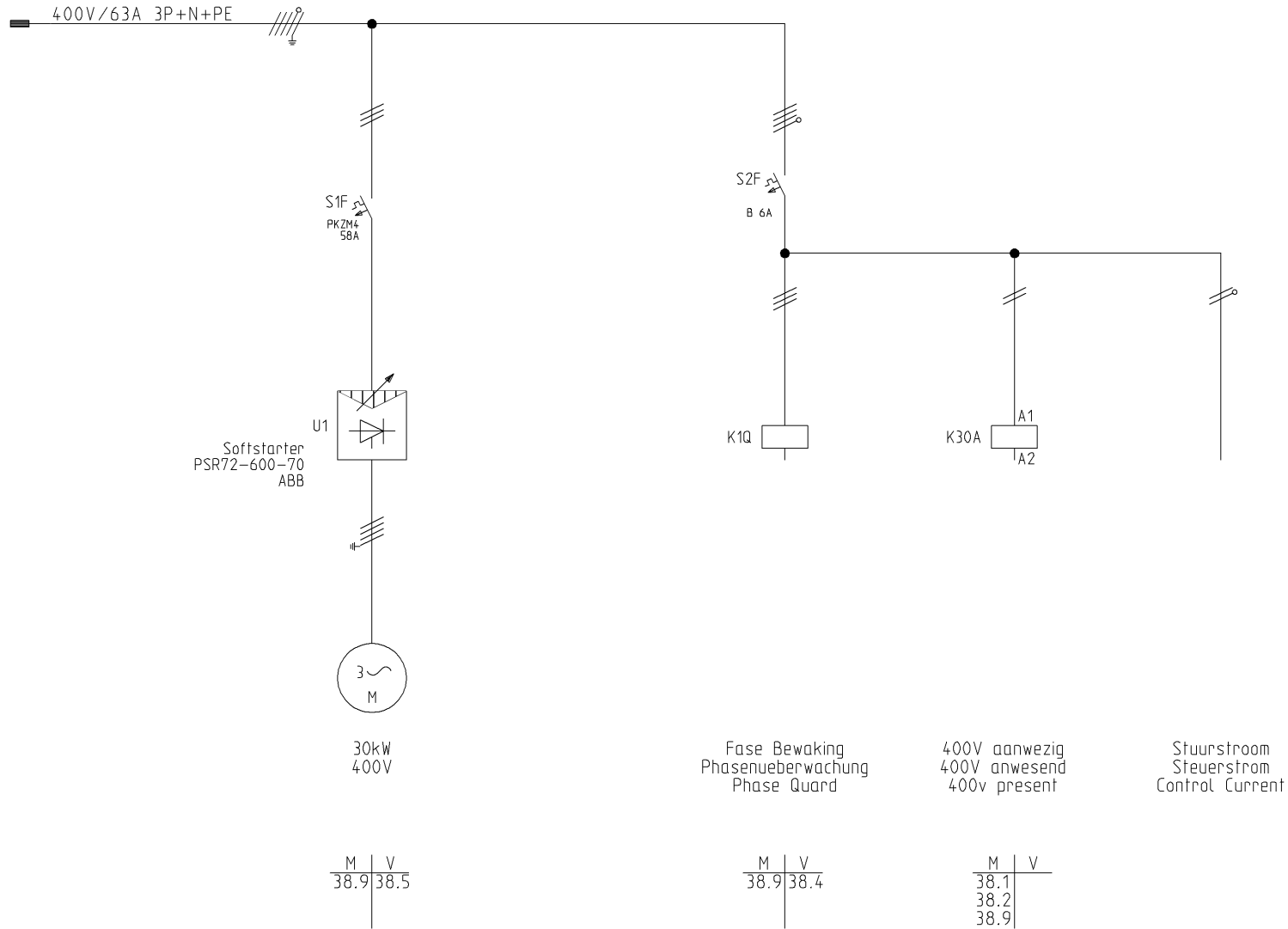

this drawing is property of Holland Lift International, by all rights reserved.
 deze tekening is eigendom van Holland Lift International, by auteursrecht voorbehouden volgens de wet.
 deze tekening is eigendom van Holland Lift International, by auteursrecht voorbehouden volgens de wet.



Holland Lift International B.V.
 Anodeweg 1
 NL-1627 LJ Hoorn The Netherlands
 T/F +31 (0)229-285555 / 285550
 E service@hollandlift.com
 W www.hollandlift.com

HOOFDSTROOMSCHEMA
 HAUPTSTROMPLAN
 MAIN CIRCUIT DIAGRAM

Projekt:	EG-21-001	Zeichnungsnummer:	Rev.:	A	erstellt von:	Rothenbusch	
Datum:	16.09.2016	Antage:	=	Ort:	+	Blatt:	37

M | V
38.9 | 38.5

M | V
38.9 | 38.4

M | V
38.1 |
38.2 |
38.9 |

Fase Bewaking
 Phasenuberwachung
 Phase Guard

400V aanwezig
 400V anwesend
 400v present

Stuurstroom
 Steuerstrom
 Control Current

EL. MOTOR 30kW
 EL. MOTOR 30kW
 EL. ENGINE 30kW

- 17.5 > U 400V E run
- 17.4 > S Fail
- 3.4 > K +24V
- 12.9 > O 400V on
- 11.2 > N Power Save
- 11.2 > Q GND

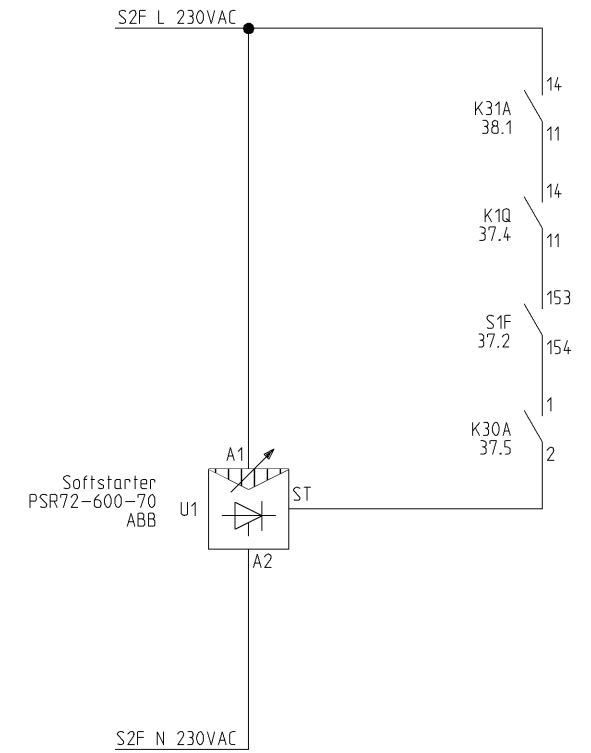
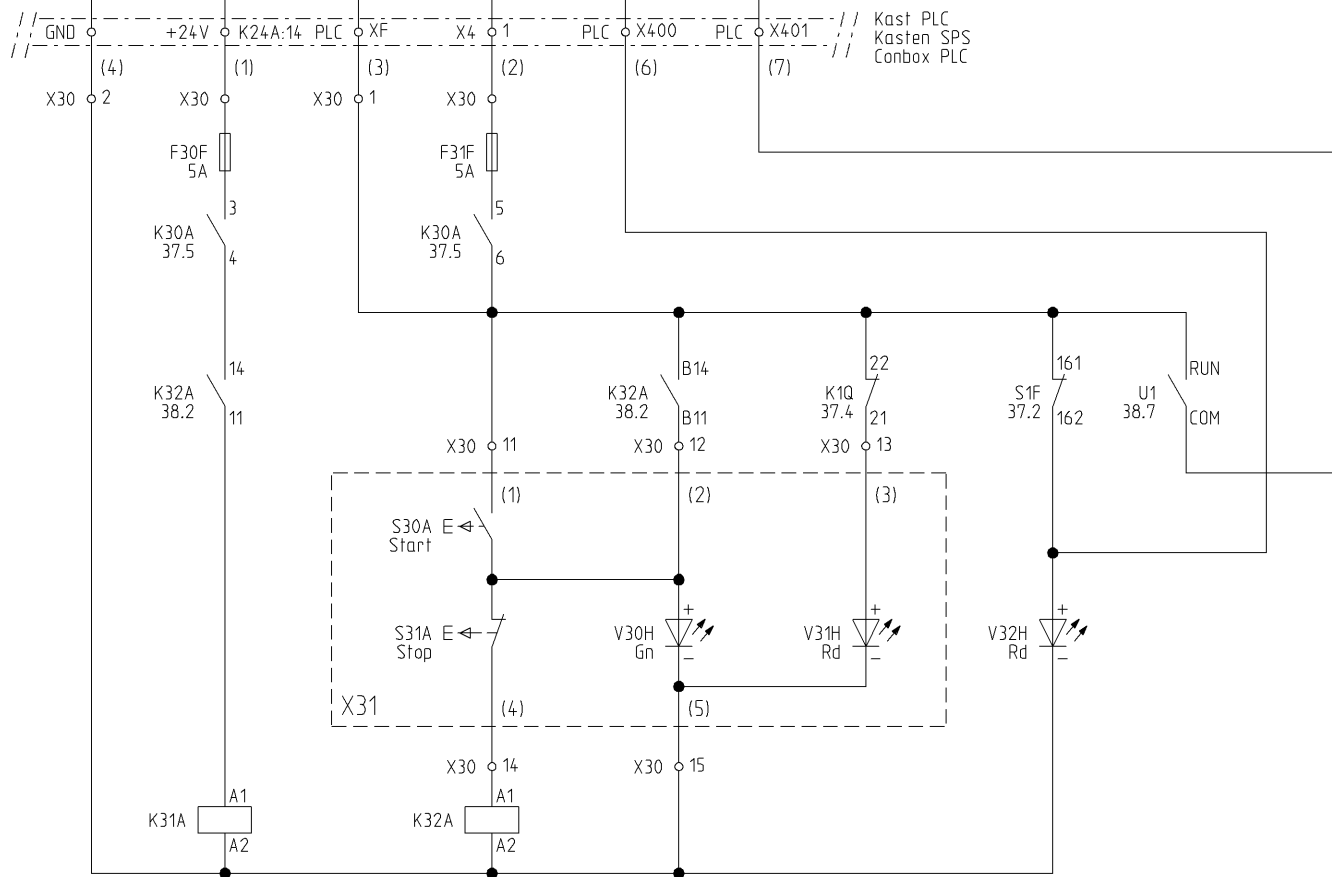

Autom. Start

El. Motor/Engine
Start/Stop

In Bedrijf/Standby
In Betrieb/Standby
Run/Standby

Draairichting fout
Drehrichtung falsch
Dir. of Rotation fault

TH. Storing
TH. Stoerung
TH. Failure

400V M Run
400V M Run
400V E Run

El. Motor/Engine 30kW
Start/Stop

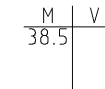
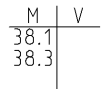
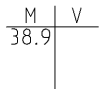

this drawing is property of Holland Lift International, by all rights reserved.
 deze tekening is eigendom van Holland Lift International, by all rights reserved.
 deze tekening is eigendom van Holland Lift International, by all rights reserved.

HOLLAND LIFT

Holland Lift International B.V.
 Anodeweg 1
 NL-1627 LJ Hoorn The Netherlands
 T/F +31 (0)229-285555 / 285550
 E service@hollandlift.com
 W www.hollandlift.com

STROOMKRINGSCHEMA
 STROMLAUFPLAN
 CIRCUIT DIAGRAM

Projekt: EG-21-001

Zeichnungsnummer:

Rev.: A

erstellt von:
Rothenbusch

Datum: 16.09.2016

Anlage: =

Ort: +

Blatt: 38