

this drawing is property of Holland Lift International, by all rights reserved
 deze tekening is eigendom van Holland Lift International, by all rights reserved
 deze tekening is eigendom van Holland Lift International, by all rights reserved

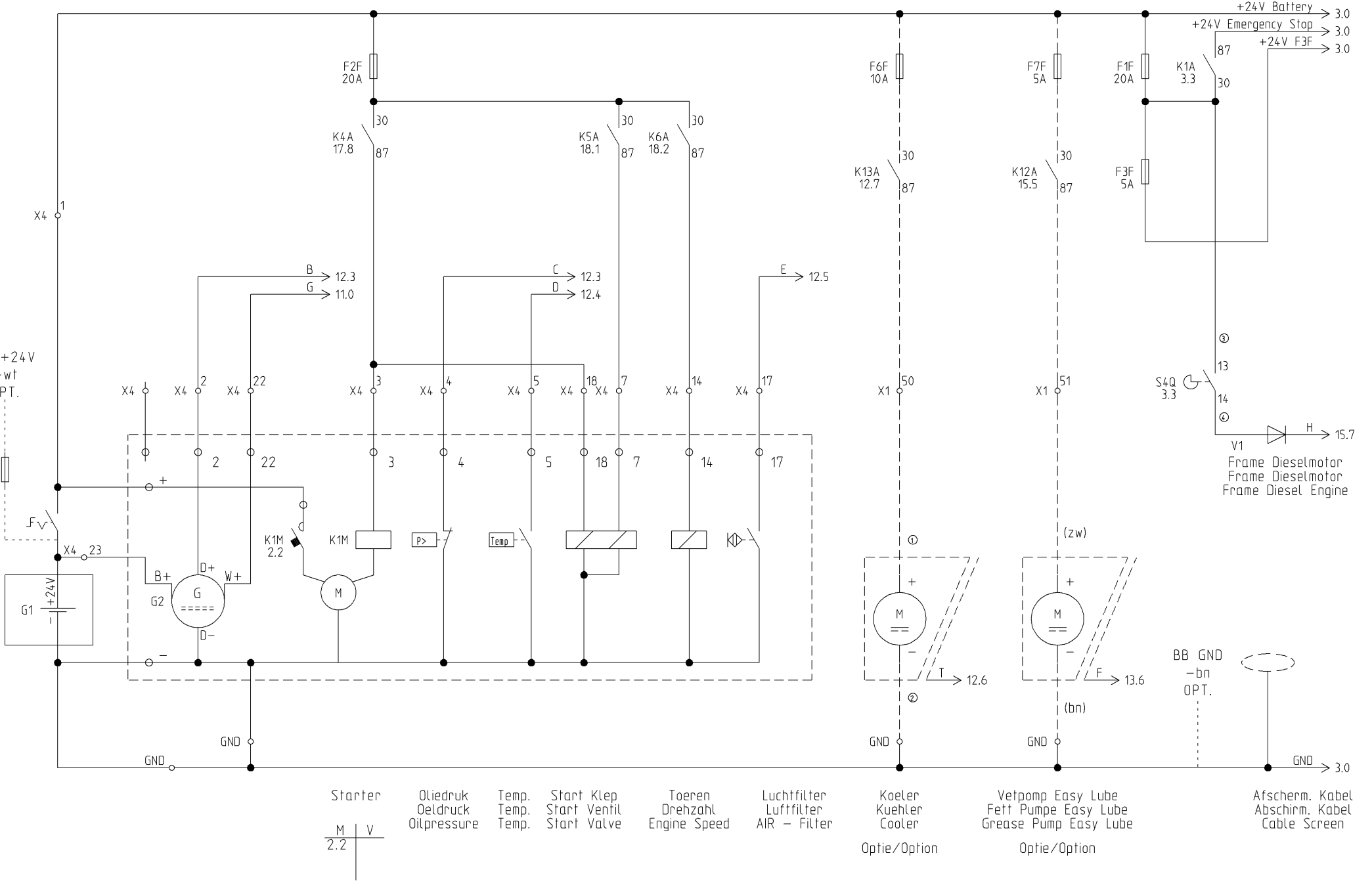

Starter
 M | V
 2.2

- Olgedruk
Oilpressure
- Temp.
Temp.
- Start Klep
Start Valve
- Toeren
Engine Speed
- Luchtfilter
AIR - Filter

- Koeler
Cooler
Optie/Option
- Vetpomp Easy Lube
Grease Pump Easy Lube
Optie/Option
- Afscherm. Kabel
Abschirm. Kabel
Cable Screen



Holland Lift International B.V.
 Anodeweg 1
 NL-1627 LJ Hoorn The Netherlands
 T/F +31 (0)229-285555 / 285550
 E service@hollandlift.com
 W www.hollandlift.com

STROOMKRINGSCHEMA
 STROMLAUFPLAN
 CIRCUIT DIAGRAM

Projekt:	EX-20-001	Zeichnungsnummer:	Rev.:	A	erstellt von:	Rothenbusch
Datum:	05.05.2017	Anlage:	=	Ort:	+	Blatt:
						2

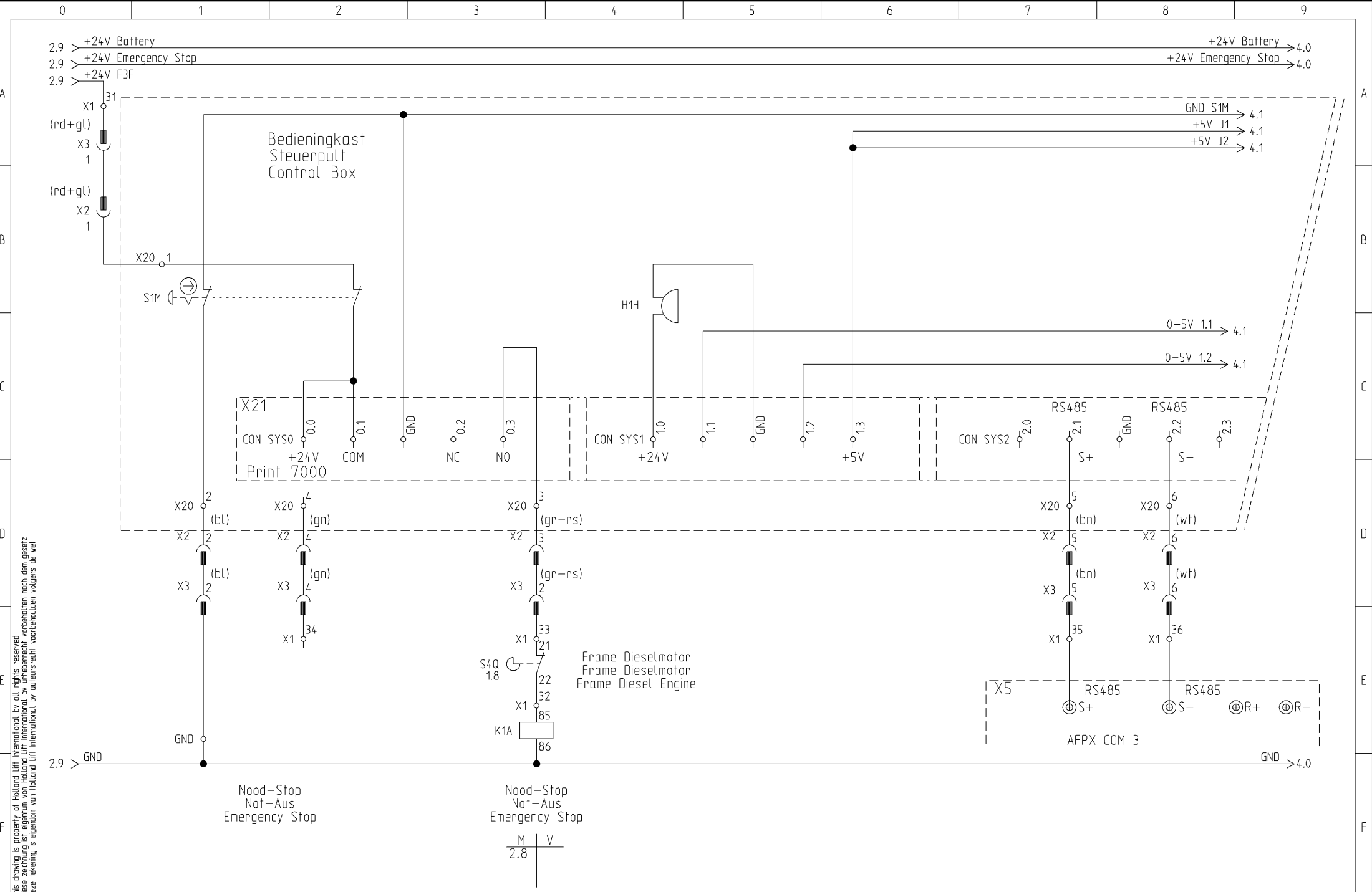

this drawing is property of Holland Lift International, by all rights reserved
 deze tekening is eigendom van Holland Lift International, by all rights reserved
 deze tekening is eigendom van Holland Lift International, by all rights reserved



Holland Lift International B.V.
 Anodeweg 1
 NL-1627 LJ Hoorn The Netherlands
 T/F +31 (0)229-285555 / 285550
 E service@hollandlift.com
 W www.hollandlift.com

STROOMKRINGSCHEMA
 STROMLAUFPLAN
 CIRCUIT DIAGRAM

Projekt:	EX-20-001	Zeichnungsnummer:	Rev.:	A	erstellt von:	Rothenbusch	
Datum:	05.05.2017	Anlage:	=	Ort:	+	Blatt:	3

3.9 > +24V Battery
 3.9 > +24V Emergency Stop

+24V Battery > 5.0
 +24V Emergency Stop > 5.0

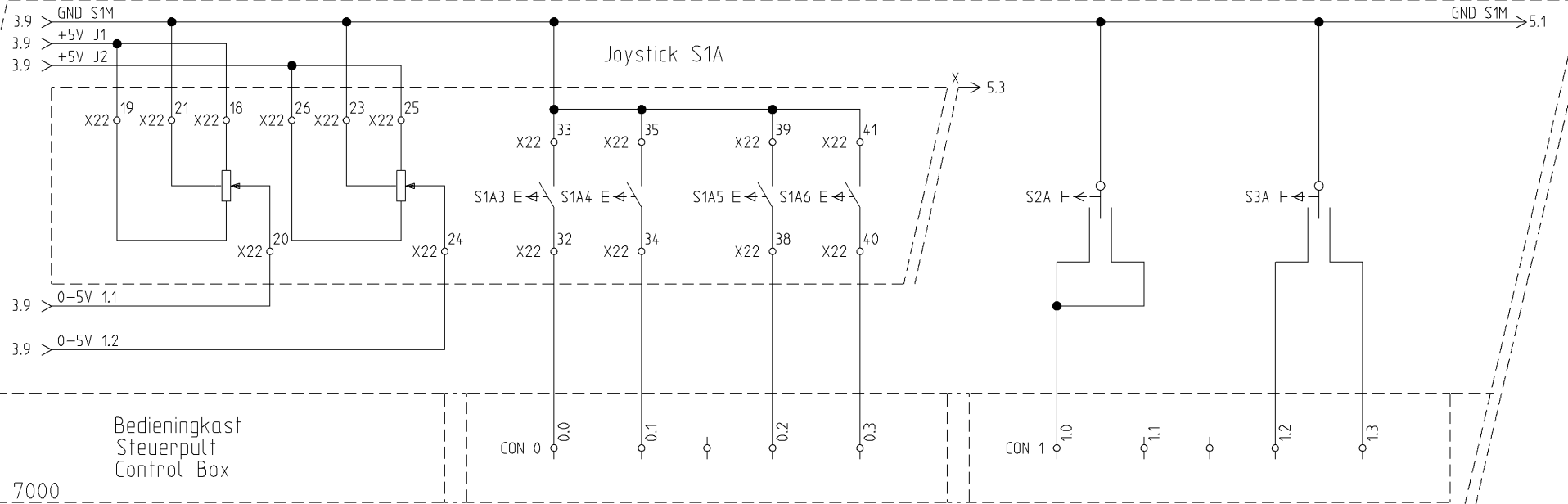

X21 Print 7000

Bedieningkast
 Steuerepult
 Control Box

3.9 > GND

GND > 5.0

Rups Links
 Raupe Links
 Track Left

Rups Rechts
 Raupe Rechts
 Track Right

Vooruit - Achteruit
 Vorw. - Rueckw.
 Forward - Reverse

Vooruit - Achteruit
 Vorw. - Rueckw.
 Forward - Reverse

Claxon-Sign.gever
 Hupe-Signalgeber
 Horn-Signal

Heffen
 Heben
 Lift Up

Dalen
 Senken
 Lift Down

Rups Links
 Raupe Links
 Track Left

Rups Rechts
 Raupe Rechts
 Track Right

this drawing is property of Holland Lift International, by all rights reserved
 diese zeichnung ist eigentum von Holland Lift International, by urheberrecht vorbehalten nach dem gesetz
 deze tekening is eigendom van Holland Lift International, by auteursrecht voorbehouden volgens de wet



Holland Lift International B.V.
 Anodeweg 1
 NL-1627 LJ Hoorn The Netherlands
 T/F +31 (0)229-285555 / 285550
 E service@hollandlift.com
 W www.hollandlift.com

STROOMKRINGSHEMA
 STROMLAUFPLAN
 CIRCUIT DIAGRAM

Projekt:	EX-20-001	Zeichnungsnummer:	Rev.:	A	erstellt von:	Rothenbusch
Datum:	05.05.2017	Anlage:	Ort:	+	Blatt:	4

4.9 > +24V Battery
4.9 > +24V Emergency Stop

+24V Battery > 6.0
+24V Emergency Stop > 6.0

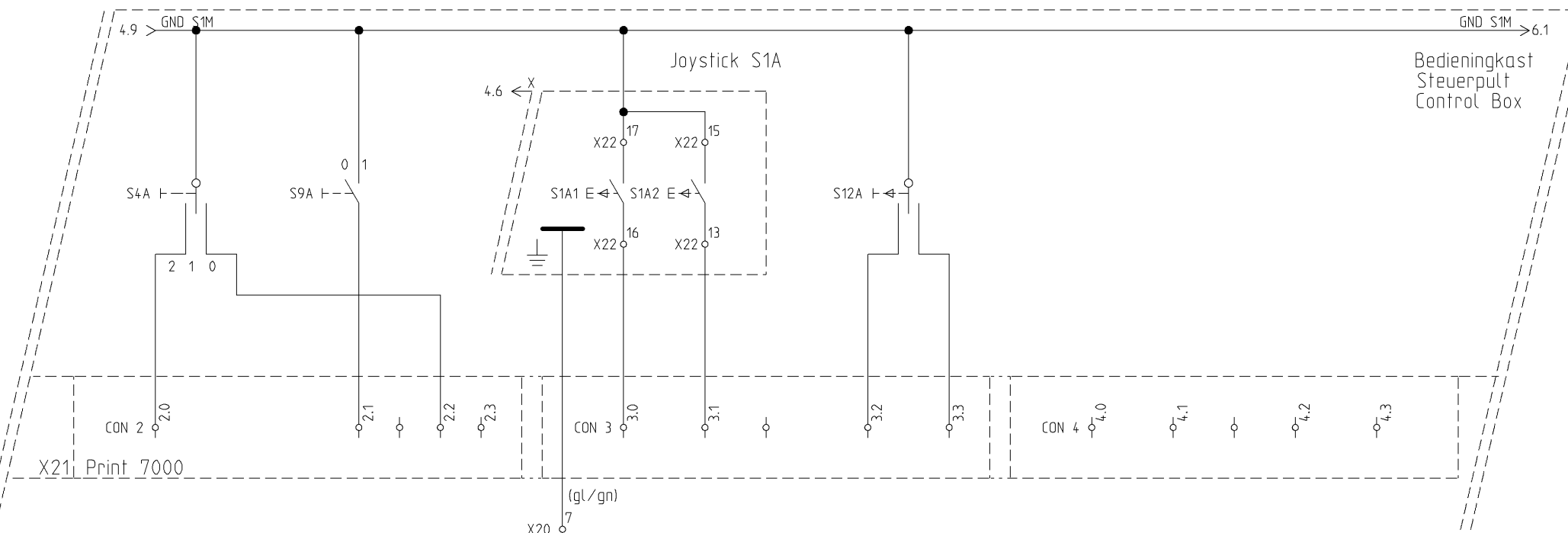

Bedieningkast
Steuerpult
Control Box

Joystick S1A

X21, Print 7000

S4A		
0 = Langzaam	Langsam	Slow
1 = Normal	Normal	Normal
2 = Snel	Schnell	Fast

S9A		
0 = Laag	Niedrig	Low
1 = Autom.	Autom.	Autom.

Snelheid
Geschwindigkeit
Speed

Toerental
Drehzahl
Enging Speed

S1A1/S1A2 Dodemansknop
S1A1/S1A2 Totmansknopf
S1A1/S1A2 Dead Man,s Button

Omhoog Vlakstellen Platform Omlaag
Hinauf Nivellierung Plattform Hinunter
Up Leveling Platform Down



this drawing is property of Holland Lift International, by all rights reserved
 deze tekening is eigendom van Holland Lift International, by auteursrecht voorbehouden volgens de wet
 deze tekening is eigendom van Holland Lift International, by auteursrecht voorbehouden volgens de wet



Holland Lift International B.V.
Anodeweg 1
NL-1627 LJ Hoorn The Netherlands
T/F +31 (0)229-285555 / 285550
E service@hollandlift.com
W www.hollandlift.com

STROOMKRINGSHEMA
STROMLAUFPLAN
CIRCUIT DIAGRAM

Projekt:	EX-20-001	Zeichnungsnummer:	Rev.:	A	erstellt von:	Rothenbusch	
Datum:	05.05.2017	Anlage:	=	Ort:	+	Blatt:	5

5.9 > +24V Battery
 5.9 > +24V Emergency Stop

+24V Battery > 7.0
 +24V Emergency Stop > 7.0

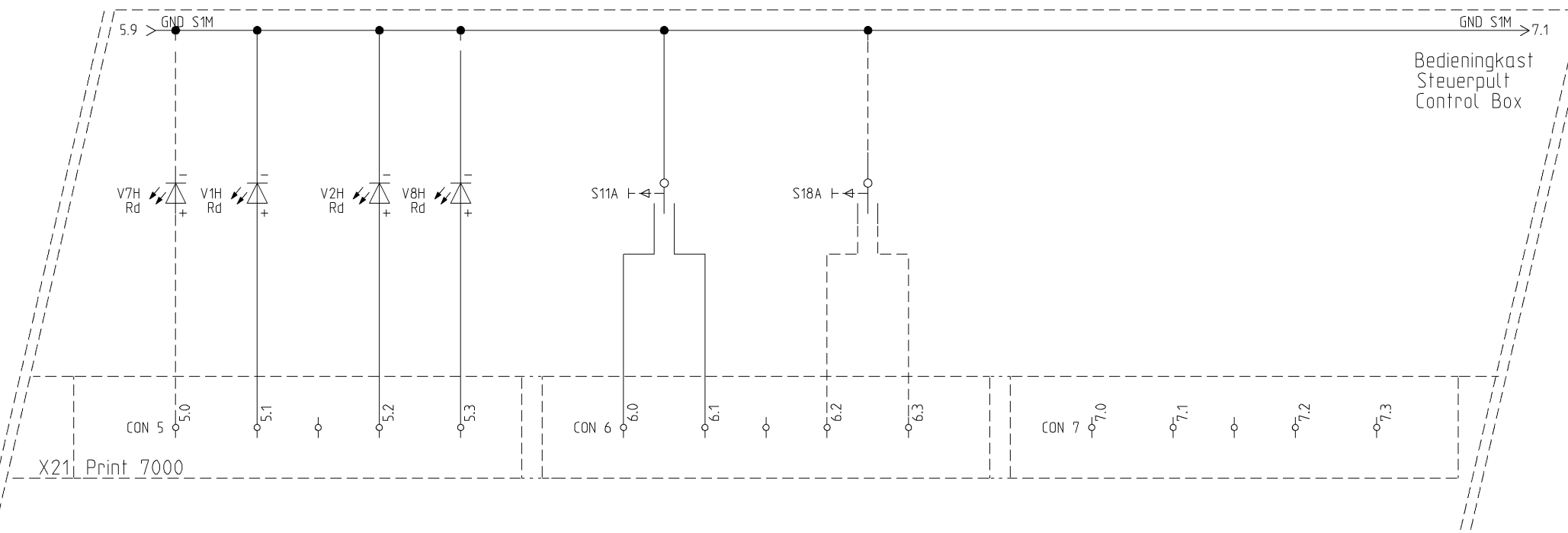

5.9 > GND

GND > 7.0

Vetpomp Overload Scheefstand Tank leeg
 Fett Pumpe Ueberlastung Neigung Tank leer
 Grease Pump Overload Grade/Slope Tank empty

Optie/Option

Start Motor Stop Aan Generator Uit
 Start Motor Stop An Generator Aus
 Start Engine Stop On Generator Off

Optie/Option

this drawing is property of Holland Lift International, by all rights reserved
 deze tekening is eigendom van Holland Lift International, by auteursrecht voorbehouden volgens de wet
 deze tekening is eigendom van Holland Lift International, by auteursrecht voorbehouden volgens de wet



Holland Lift International B.V.
 Anodeweg 1
 NL-1627 LJ Hoorn The Netherlands
 T/F +31 (0)229-285555 / 285550
 E service@hollandlift.com
 W www.hollandlift.com

STROOMKRINGSHEMA
 STROMLAUFPLAN
 CIRCUIT DIAGRAM

Projekt:	EX-20-001	Zeichnungsnummer:	Rev.:	A	erstellt von:	Rothenbusch
Datum:	05.05.2017	Anlage:	Ort:	+	Blatt:	6

6.9 > +24V Battery
 6.9 > +24V Emergency Stop

+24V Battery > 8.0
 +24V Emergency Stop > 8.0

6.9 > GND S1M

GND S1M >

Bedieningkast
 Steuerpult
 Control Box

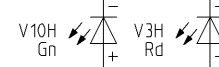

CON 8 8.0

8.1

8.2

8.3

CON 9 9.0

9.1

9.2

9.3

CON 10 10.0

10.1

10.2

10.3

X21, Print 7000

6.9 > GND

GND > 8.0

In Bedrijf Storing
 In Betrieb Stoerung
 Run Failure

Diesel Motor

this drawing is property of Holland Lift International, by all rights reserved
 deze tekening is eigendom van Holland Lift International, by all rights reserved
 deze tekening is eigendom van Holland Lift International, by all rights reserved

HOLLAND LIFT

Holland Lift International B.V.
 Anodeweg 1
 NL-1627 LJ Hoorn The Netherlands
 T/F +31 (0)229-285555 / 285550
 E service@hollandlift.com
 W www.hollandlift.com

STROOMKRINGSCHEMA
 STROMLAUFPLAN
 CIRCUIT DIAGRAM

Projekt: EX-20-001

Zeichnungsnummer:

Rev.: A

erstellt von:
 Rothenbusch

Datum: 05.05.2017

Anlage: =

Ort: +

Blatt: 7

7.9 > +24V Battery +24V Battery > 9.0
 7.9 > +24V Emergency Stop +24V Emergency Stop > 9.0

Bedieningkast
 Steuerpult
 Control Box

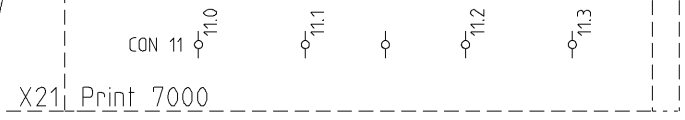

7.9 > GND GND > 9.0

this drawing is property of Holland Lift International, by all rights reserved
 deze tekening is eigendom van Holland Lift International, by auteursrecht voorbehouden volgens de wet
 deze tekening is eigendom van Holland Lift International, by auteursrecht voorbehouden volgens de wet



Holland Lift International B.V.
 Anodeweg 1
 NL-1627 LJ Hoorn The Netherlands
 T/F +31 (0)229-285555 / 285550
 E service@hollandlift.com
 W www.hollandlift.com

STROOMKRINGSCHEMA
 STROMLAUFPLAN
 CIRCUIT DIAGRAM

Projekt:	EX-20-001	Zeichnungsnummer:	Rev.:	A	erstellt von:	Rothenbusch	
Datum:	05.05.2017	Antage:	=	Ort:	+	Blatt:	8

this drawing is property of Holland Lift International, by all rights reserved.
 deze tekening is eigendom van Holland Lift International, by all rights reserved.
 deze tekening is eigendom van Holland Lift International, by auteursrecht voorbehouden volgens de wet

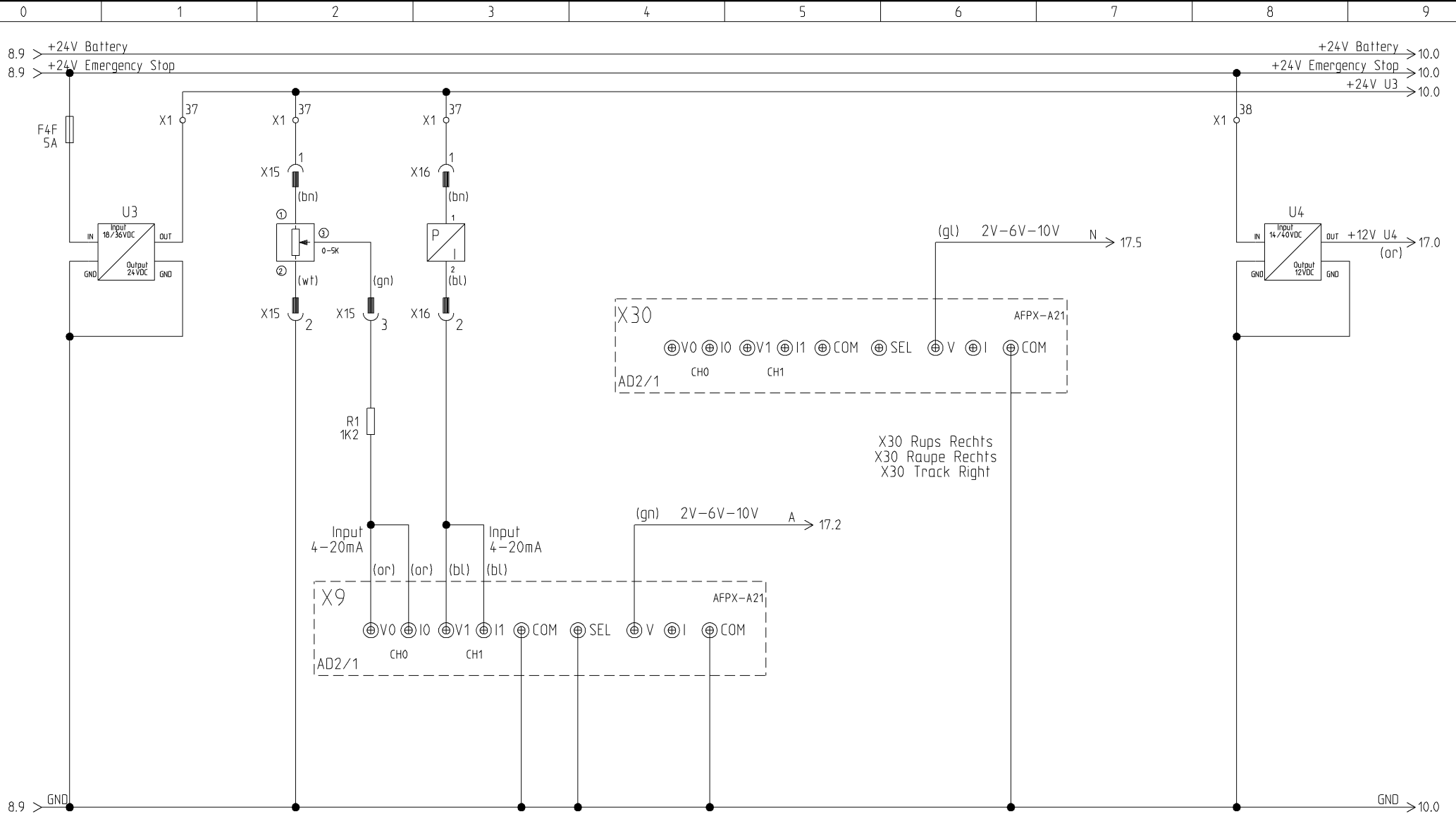

Hoekmeting
 Winkel Messung
 Angle Measuring

Druk Meting
 Druck Messung
 Pressure Measuring

X9 Rups Links
 X9 Raupe Links
 X9 Track Left

X30 Rups Rechts
 X30 Raupe Rechts
 X30 Track Right

this drawing is property of Holland Lift International, by all rights reserved
 deze tekening is eigendom van Holland Lift International, by auteursrecht voorbehouden volgens de wet
 deze tekening is eigendom van Holland Lift International, by auteursrecht voorbehouden volgens de wet

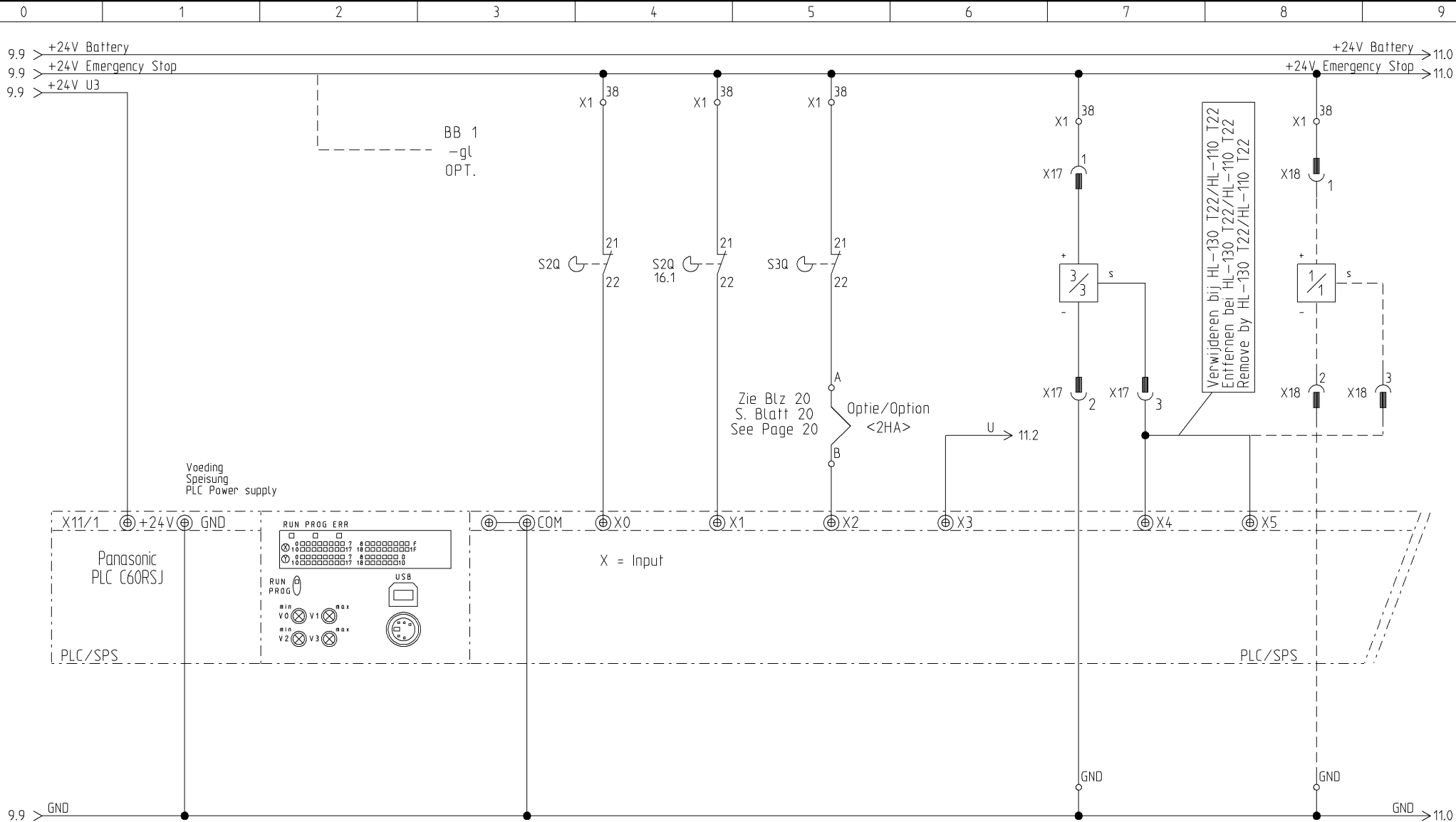

2,5 mtr. Afslag 4,5 mtr. Afslag Max. Hodgte Dalen Onderwagen Scheefstand 3/3
 2,5 mtr. Ausschalt. 4,5 mtr. Ausschalt. Max. Hoehe Senken Chassis Neigung 3/3
 2,5 mtr. Cut-Out 4,5 mtr. Cut-Out Max. Height Lift Down Chassis Grade/Slope 3/3

Scheefstand 1/1
 Neigung 1/1
 Grade/Slope 1/1

Optie/Option
 HL-130 T22/HL-110 T22



Holland Lift International B.V.
 Anodeweg 1
 NL-1627 LJ Hoorn The Netherlands
 T/F +31 (0)229-285555 / 285550
 E service@hollandlift.com
 W www.hollandlift.com

STROOMKRINGSHEMA
 STROMLAUFPLAN
 CIRCUIT DIAGRAM

Projekt:	EX-20-001	Zeichnungsnummer:	Rev.:	A	erstellt von:	Rothenbusch
Datum:	05.05.2017	Anlage:	Ort:	+	Blatt:	10

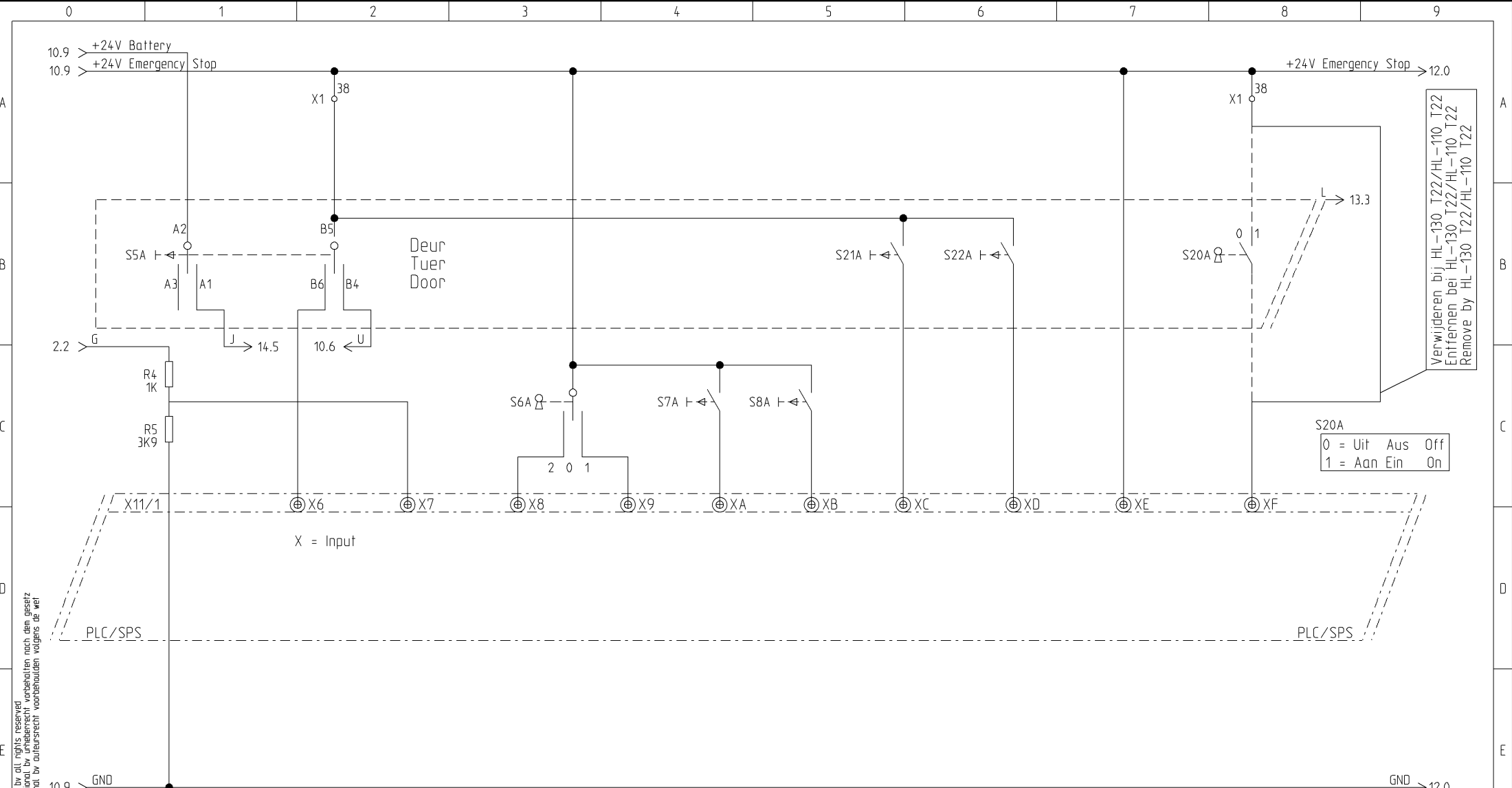

this drawing is property of Holland Lift International, by all rights reserved
 deze tekening is eigendom van Holland Lift International, by all rights reserved
 deze tekening is eigendom van Holland Lift International, by all rights reserved

Daten Onderwagen Senken Chassis Lift Down Chassis	Heffen - Daem W+ Dieselmotor Heben - Senken Lift Up - Lift Down	Progr. Uif Progr. Aus Progr. Off	Aan An On	Store Store Store	Save Save Save	Start - Motor - Stop Start - Motor - Halt Start - Engine - Stop	Overbr. Daalbev Ueberbr. Senkschutz Bridge Lift down protec.	Ri. max. Hoogte Fa. max. Hoehe Dr. max. Height
---	---	--	-----------------	-------------------------	----------------------	---	--	--

Overlastin-Ueberlastung-Overload

HL-130 T22/HL-110 T22 Optie/Option
 HL-130 T22/HL-110 T22



Holland Lift International B.V.
 Anodeweg 1
 NL-1627 LJ Hoorn The Netherlands
 T/F +31 (0)229-285555 / 285550
 E service@hollandlift.com
 W www.hollandlift.com

STROOMKRINGSCHEMA
 STROMLAUFPLAN
 CIRCUIT DIAGRAM

Projekt: EX-20-001	Zeichnungsnummer:	Rev.: A	erstellt von: Rothenbusch
Datum: 05.05.2017	Anlage: =	Ort: +	Blatt: 11

this drawing is property of Holland Lift International, by all rights reserved
 deze tekening is eigendom van Holland Lift International, by all rights reserved
 deze tekening is eigendom van Holland Lift International, by all rights reserved

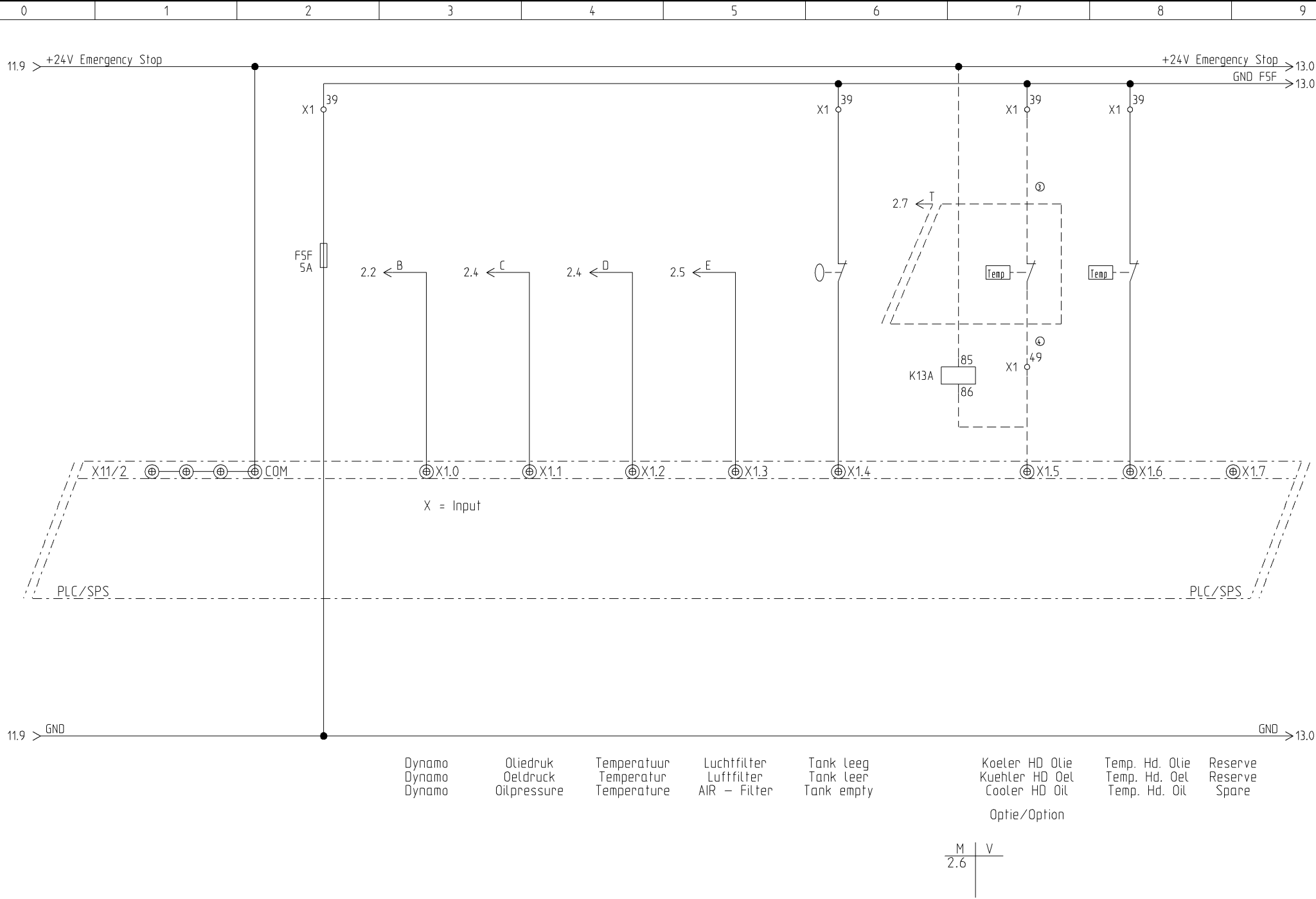

- | | | | | | | | |
|--------|-------------|-------------|--------------|------------|----------------|----------------|---------|
| Dynamo | Olgedruk | Temperatuur | Luchtfilter | Tank leeg | Koeler HD Olie | Temp. Hd. Olie | Reserve |
| Dynamo | Oelgedruk | Temperatuur | Luffilter | Tank leer | Kuehler HD Oel | Temp. Hd. Oel | Reserve |
| Dynamo | Oilpressure | Temperature | AIR - Filter | Tank empty | Cooler HD Oil | Temp. Hd. Oil | Spare |
- Optie/Option

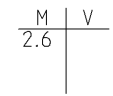

Holland Lift International B.V.
 Anodeweg 1
 NL-1627 LJ Hoorn The Netherlands
 T/F +31 (0)229-285555 / 285550
 E service@hollandlift.com
 W www.hollandlift.com

STROOMKRINGSCHEMA
 STROMLAUFPLAN
 CIRCUIT DIAGRAM

Projekt:	EX-20-001	Zeichnungsnummer:	Rev.:	A	erstellt von:	Rothenbusch
Datum:	05.05.2017	Anlage:	=	+	Blatt:	12

this drawing is property of Holland Lift International. All rights reserved.
 deze tekening is eigendom van Holland Lift International. Alle rechten voorbehouden volgens de wet.
 deze tekening is eigendom van Holland Lift International. Alle rechten voorbehouden volgens de wet.

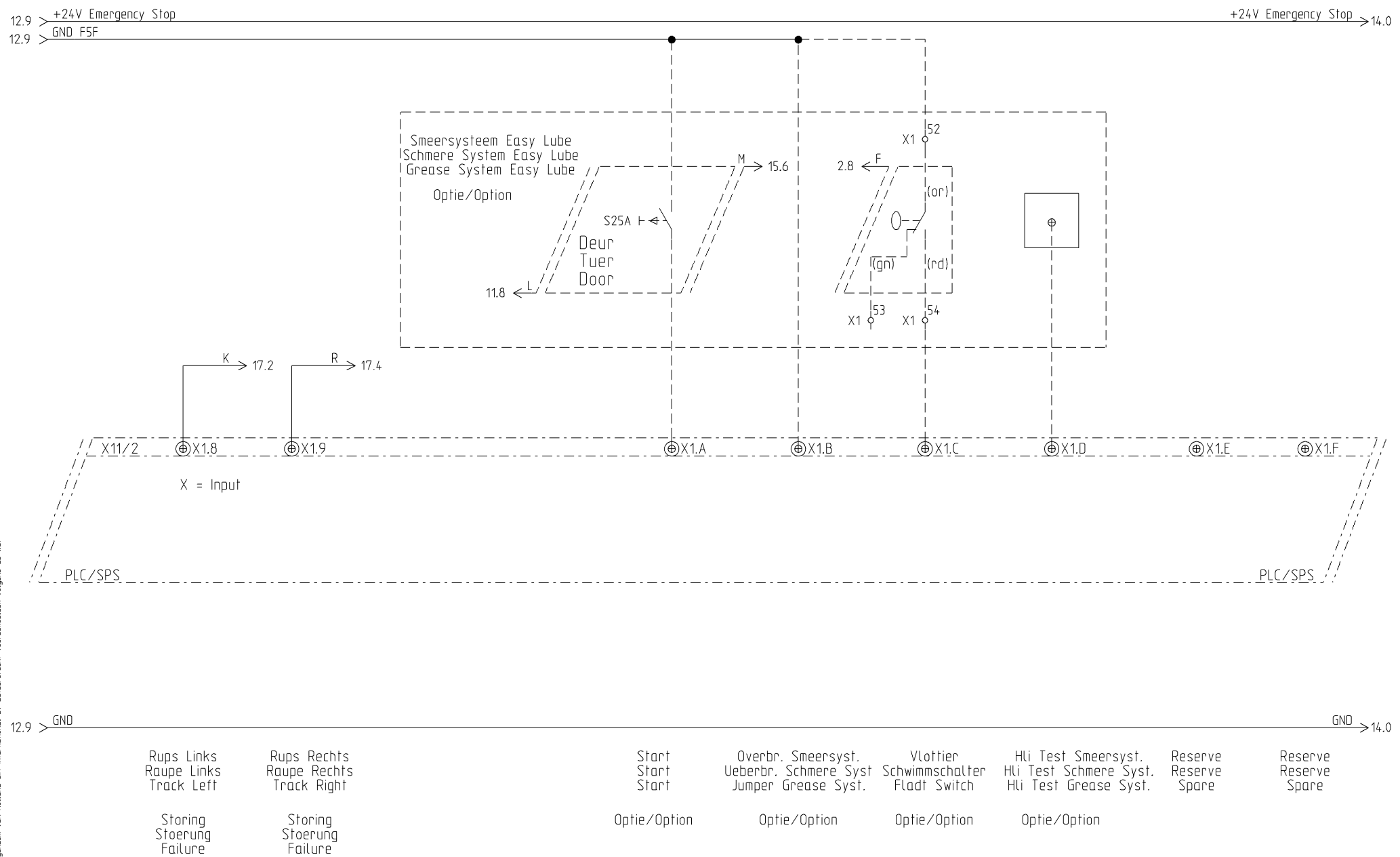

Rups Links
 Raupe Links
 Track Left
 Storing
 Stoerung
 Failure

Rups Rechts
 Raupe Rechts
 Track Right
 Storing
 Stoerung
 Failure

Start
 Start
 Start
 Optie/Option

Overbr. Smeersyst.
 Ueberbr. Schmere Syst
 Jumper Grease Syst.
 Optie/Option

Vlottier
 Schwimmshalter
 Fladt Switch
 Optie/Option

Hli Test Smeersyst.
 Hli Test Schmere Syst.
 Hli Test Grease Syst.
 Optie/Option

Reserve
 Reserve
 Spare

Reserve
 Reserve
 Spare

this drawing is property of Holland Lift International. All rights reserved.
 deze tekening is eigendom van Holland Lift International. Alle rechten voorbehouden.
 deze tekening is eigendom van Holland Lift International. Alle rechten voorbehouden volgens de wet.

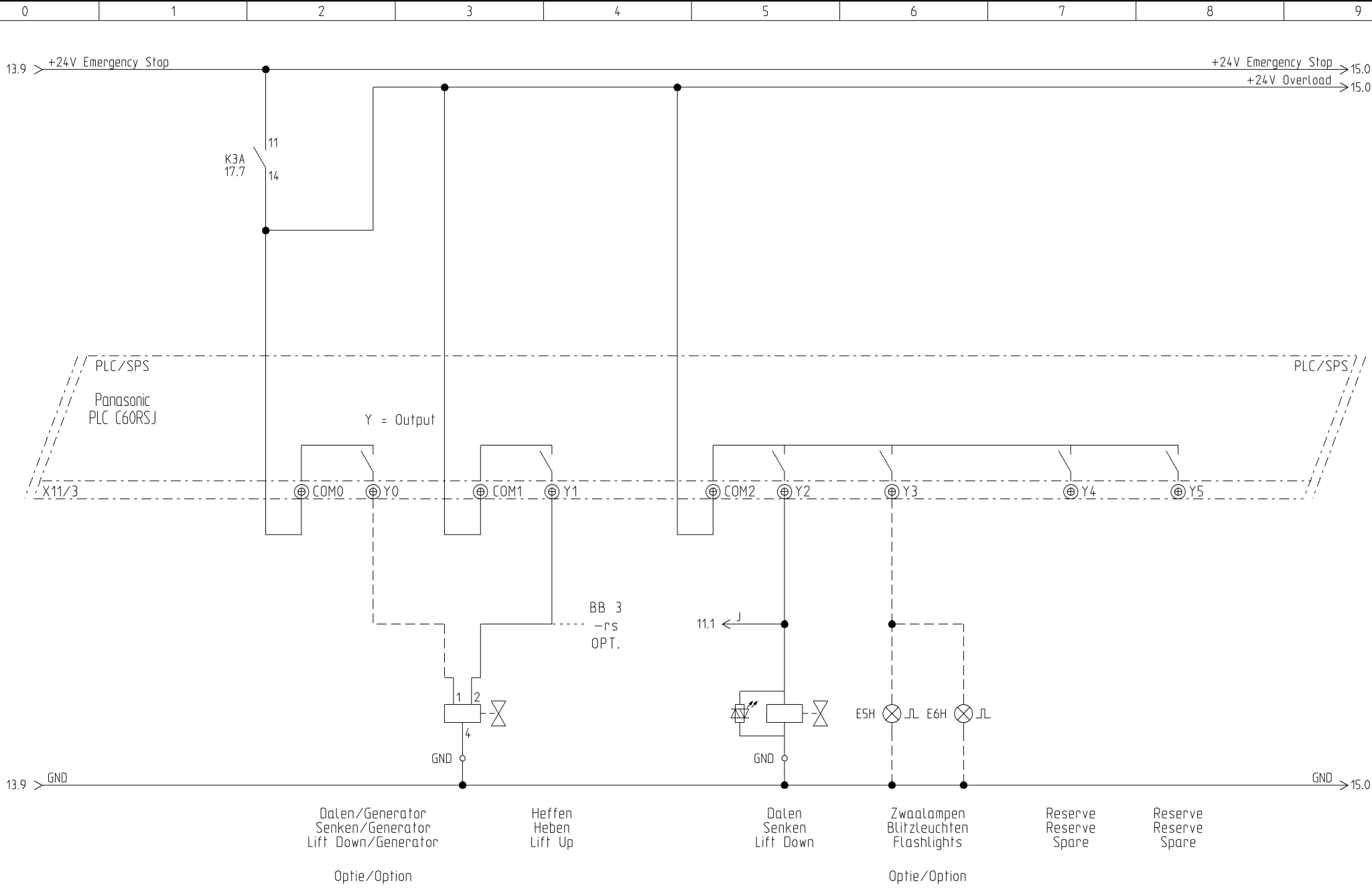

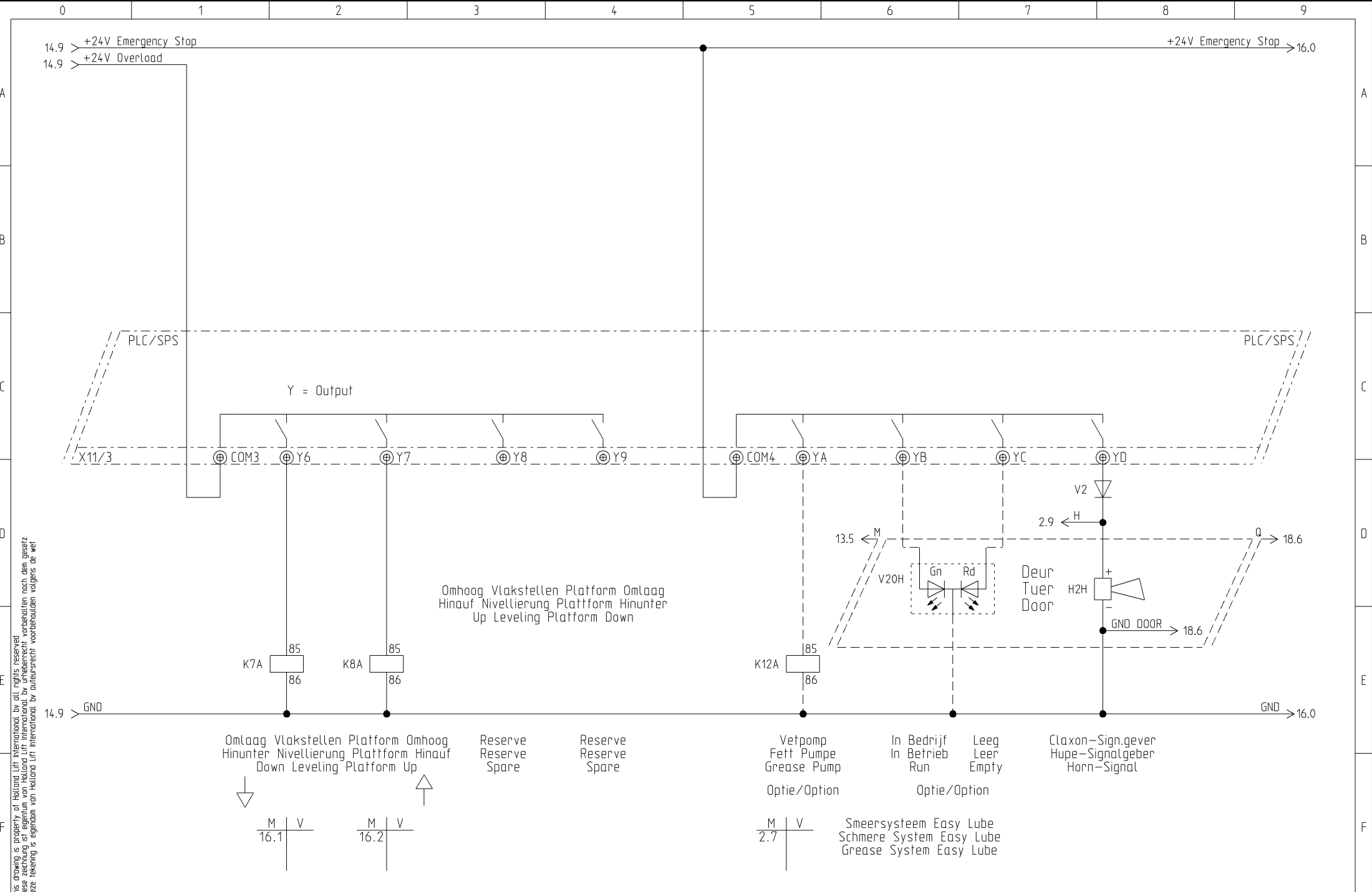

this drawing is property of Holland Lift International, by all rights reserved
 deze tekening is eigendom van Holland Lift International, by all rights reserved
 deze tekening is eigendom van Holland Lift International, by all rights reserved

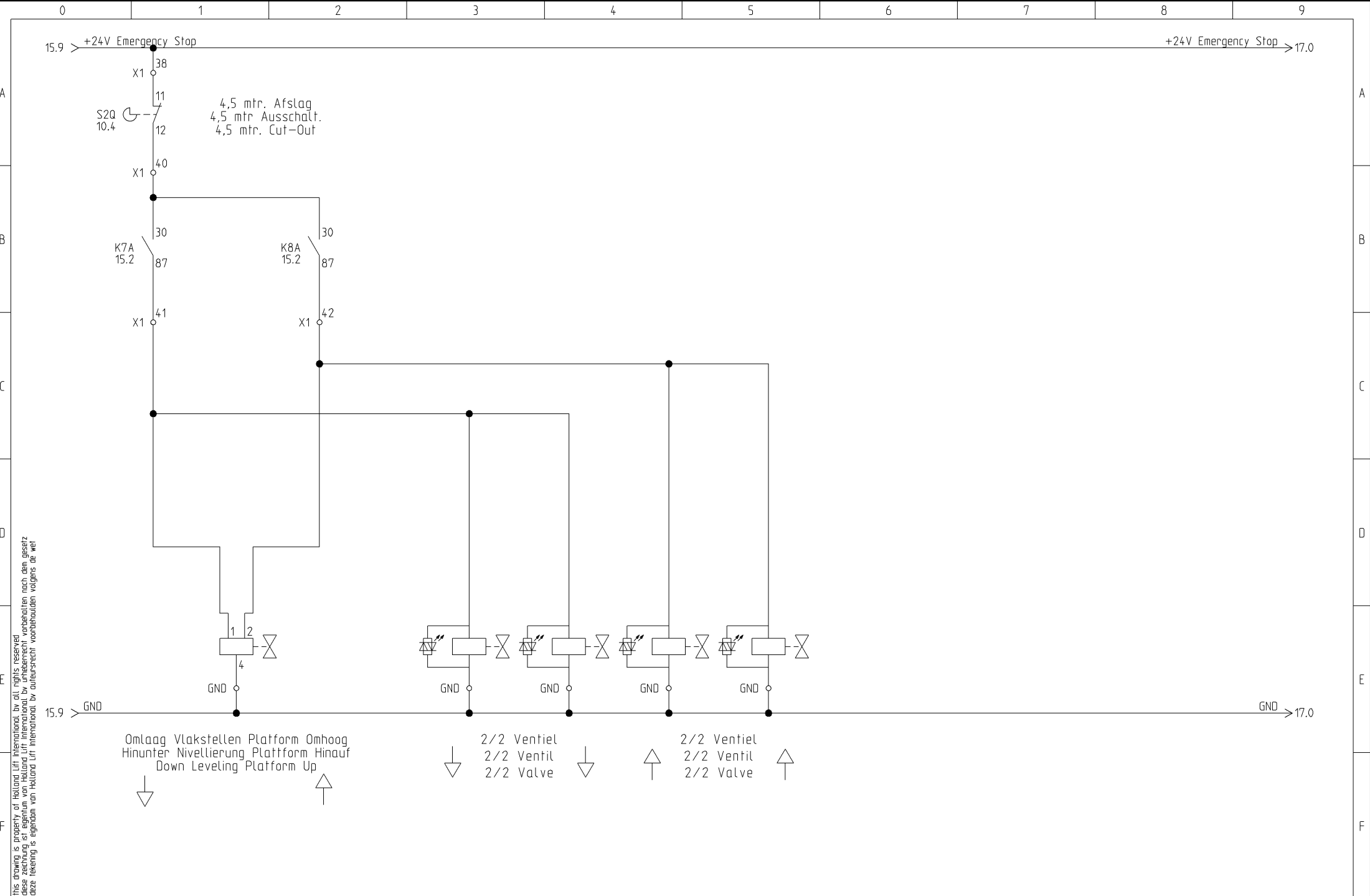

this drawing is property of Holland Lift International, by all rights reserved
 deze tekening is eigendom van Holland Lift International, by auteursrecht voorbehouden volgens de wet
 deze tekening is eigendom van Holland Lift International, by auteursrecht voorbehouden volgens de wet



Holland Lift International B.V.
 Anodeweg 1
 NL-1627 LJ Hoorn The Netherlands
 T/F +31 (0)229-285555 / 285550
 E service@hollandlift.com
 W www.hollandlift.com

STROOMKRINGSCHEMA
 STROMLAUFPLAN
 CIRCUIT DIAGRAM

Projekt:	EX-20-001	Zeichnungsnummer:	Rev.:	A	erstellt von:	Rothenbusch	
Datum:	05.05.2017	Anlage:	=	Ort:	+	Blatt:	16

this drawing is property of Holland Lift International, by all rights reserved
 deze tekening is eigendom van Holland Lift International, by all rights reserved
 deze tekening is eigendom van Holland Lift International, by all rights reserved

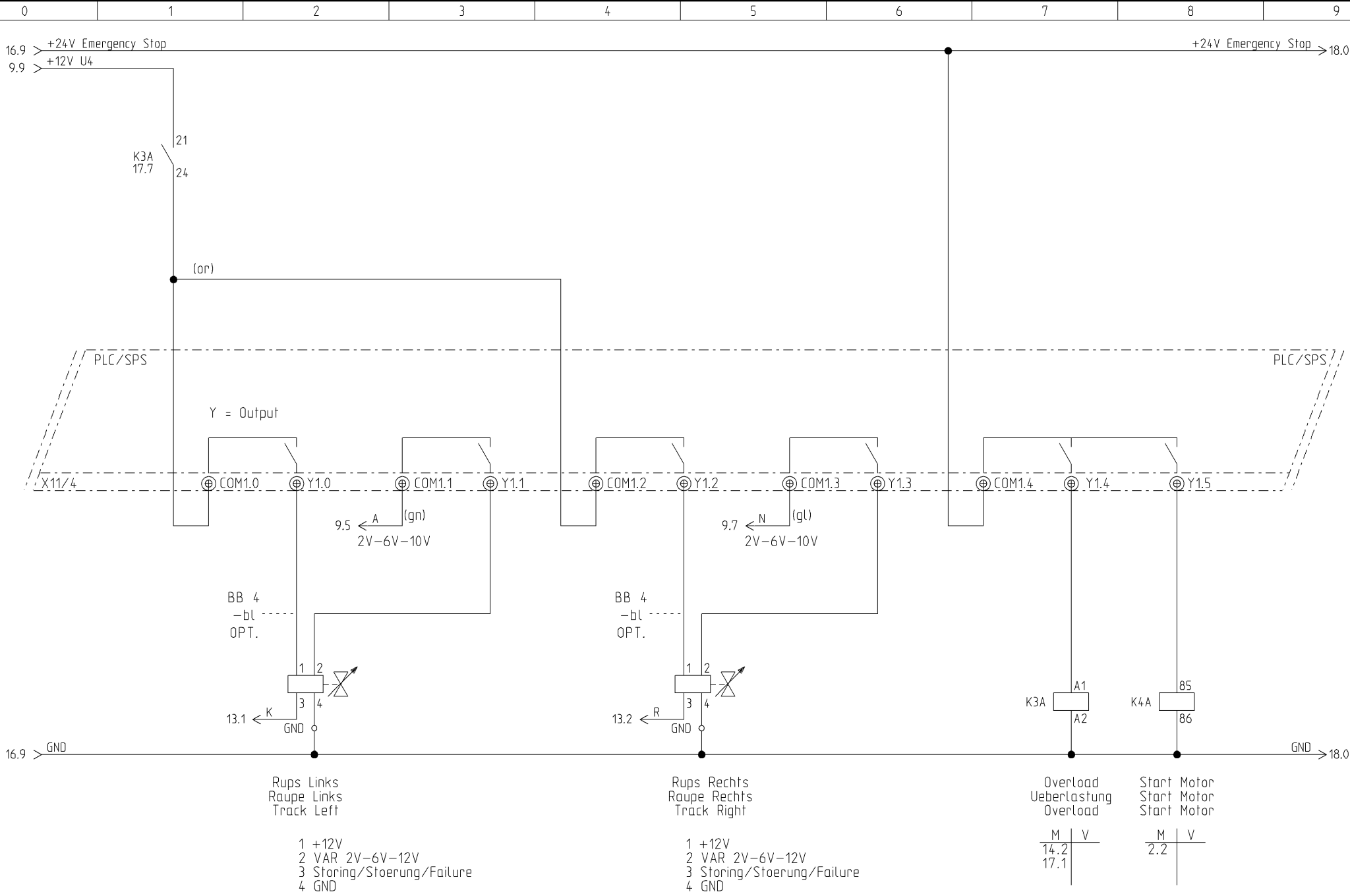

Holland Lift International B.V.
 Anodeweg 1
 NL-1627 LJ Hoorn The Netherlands
 T/F +31 (0)229-285555 / 285550
 E service@hollandlift.com
 W www.hollandlift.com

STROOMKRINGSCHEMA
 STROMLAUFPLAN
 CIRCUIT DIAGRAM

Projekt:	EX-20-001	Zeichnungsnummer:	Rev.:	A	erstellt von:	Rothenbusch
Datum:	05.05.2017	Anlage:	Ort:	=	Blatt:	17

this drawing is property of Holland Lift International. By all rights reserved.
 deze tekening is eigendom van Holland Lift International. By auteursrecht voorbehouden volgens de wet.
 deze tekening is eigendom van Holland Lift International. By auteursrecht voorbehouden volgens de wet.

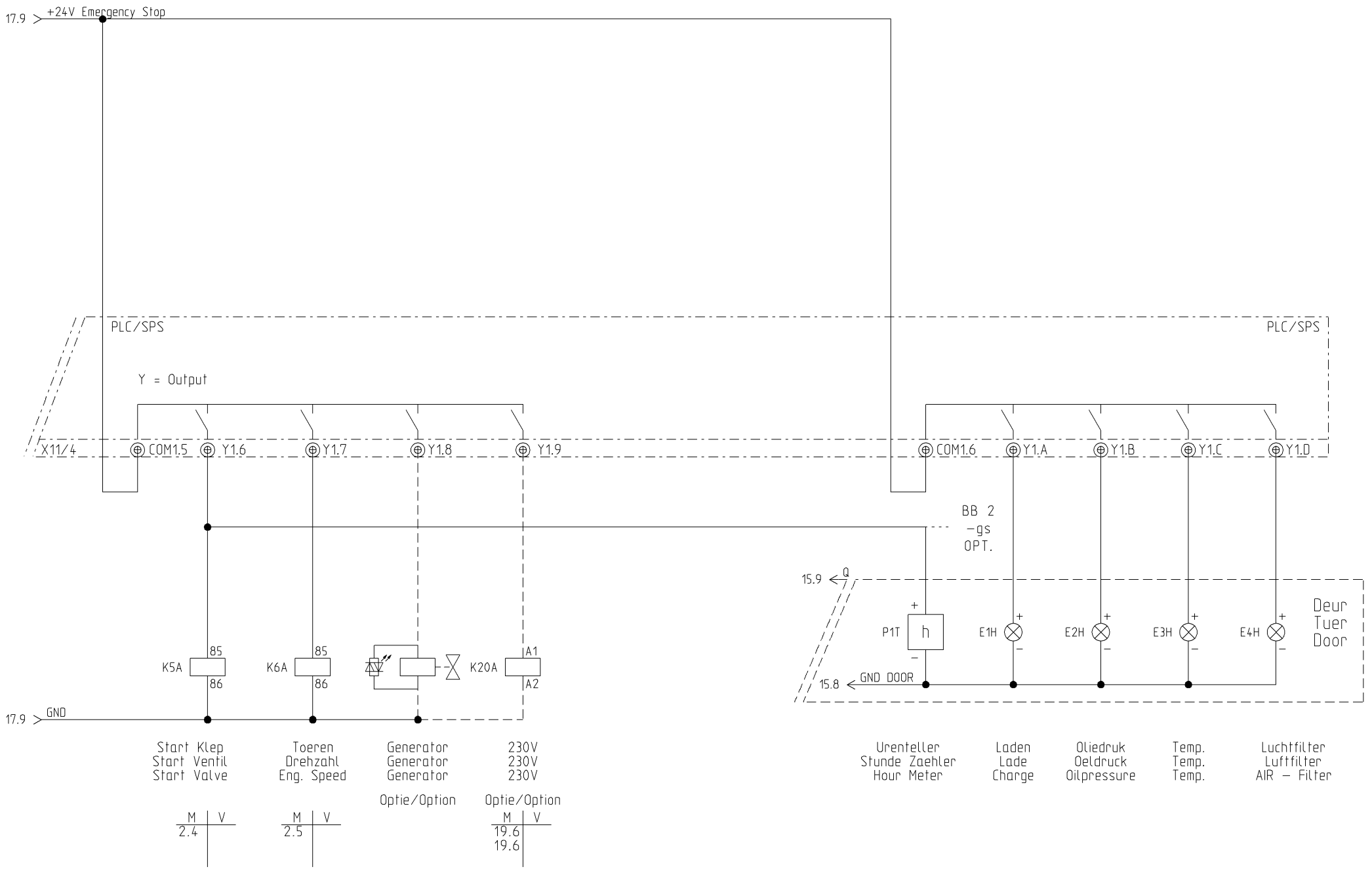

OPTIES
OPTIONEN
OPTIONS

230V AANSLUITING PLATFORM
230V ANSCHLUSS PLATTFORM
230V SUPPLY PLATFORM

<230VPLF>

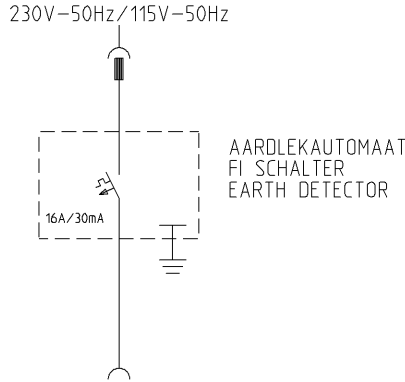

230V AANSLUITING PLATFORM
230V ANSCHLUSS PLATTFORM
230V SUPPLY PLATFORM

<230V-GEN>

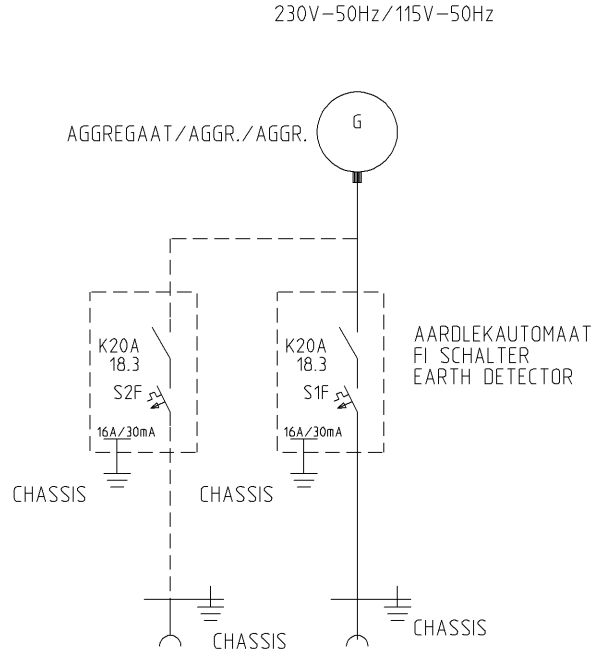

this drawing is property of Holland Lift International, by all rights reserved
 diese zeichnung ist eigentum von Holland Lift International, by urheberrecht vorbehalten nach dem gesetz
 deze tekening is eigendom van Holland Lift International, by auteursrecht voorbehouden volgens de wet



Holland Lift International B.V.
Anodeweg 1
NL-1627 LJ Hoorn The Netherlands
T/F +31 (0)229-285555 / 285550
E service@hollandlift.com
W www.hollandlift.com

OPTIES
OPTIONEN
OPTIONS

Projekt: EX-20-001

Zeichnungsnummer:

Rev.: A

erstellt von:
Rothenbusch

Datum: 05.05.2017

Antage: =

Ort: +

Blatt: 19

OPTIES
OPTIONEN
OPTIONS

2e HOOGTE AFLSAG
2e HOEHE AUSSCHALTUNG
2nd HEIGHT CUT-OUT

<2HA>

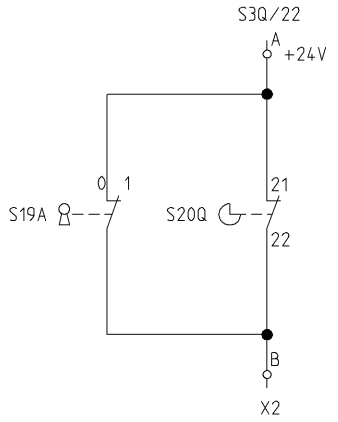

Zie Blz 10
S. Blatt 10
See Page 10

S19A

0	= Max. HOOGTE /Max. HOEHE/Max. HEIGHT
1	= 2e HOOGTE AFL./2e H. AUSS./2nd H. CUT-OUT

OPTIE BLACK-BOX MINI DAT
OPTION BLACK-BOX MINI DAT
OPTION BLACK-BOX MINI DAT

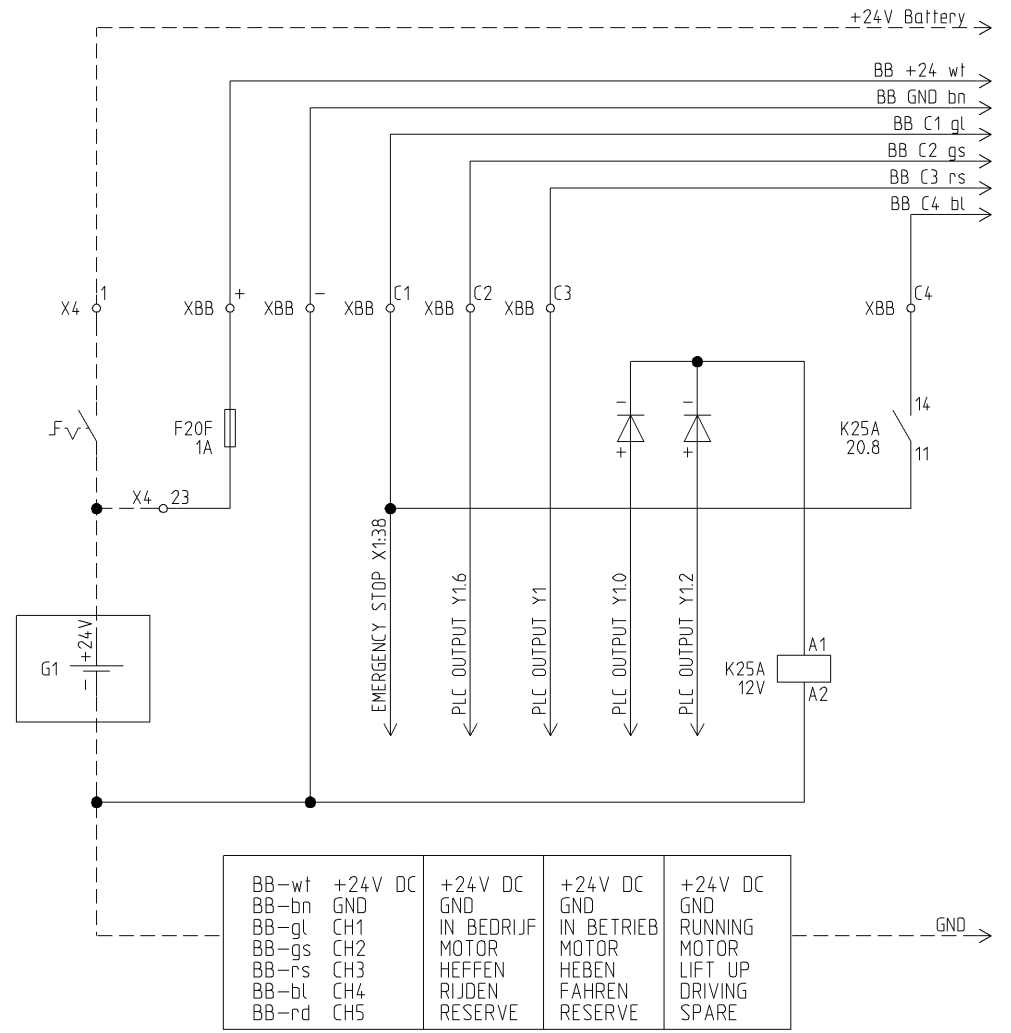

BB-wt	+24V DC	+24V DC	+24V DC	+24V DC
BB-bn	GND	GND	GND	GND
BB-gl	CH1	IN BEDRIJF	IN BETRIEF	RUNNING
BB-gs	CH2	MOTOR	MOTOR	MOTOR
BB-rs	CH3	HEFFEN	HEBEN	LIFT UP
BB-bl	CH4	RIJDEN	FAHREN	DRIVING
BB-rd	CH5	RESERVE	RESERVE	SPARE

this drawing is property of Holland Lift International, by all rights reserved
 deze tekening is eigendom van Holland Lift International, by all rights reserved
 deze tekening is eigendom van Holland Lift International, by all rights reserved



Holland Lift International B.V.
Anodeweg 1
NL-1627 LJ Hoorn The Netherlands
T/F +31 (0)229-285555 / 285550
E service@hollandlift.com
W www.hollandlift.com

OPTIES
OPTIONEN
OPTIONS

Projekt:	EX-20-001	Zeichnungsnummer:	Rev.:	A	erstellt von:	Rothenbusch	
Datum:	05.05.2017	Anlage:	=	Ort:	+	Blatt:	20

KLEMMENKAST KLEMMENKASTEN CONNECTION BOX

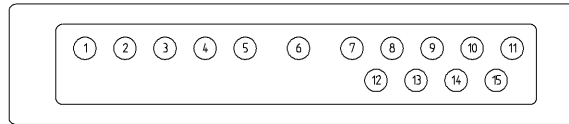
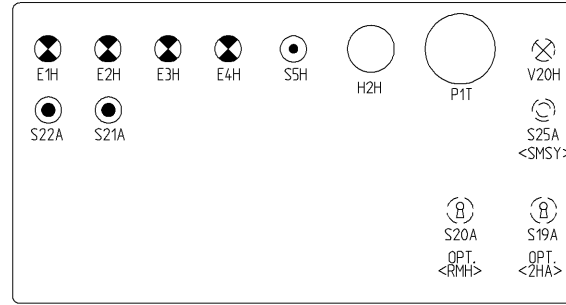
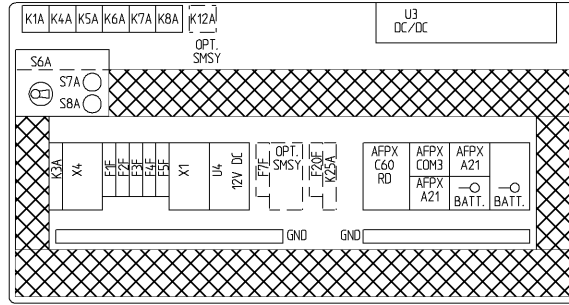

1-5 / 7-15 M20
6 Hatz

Colour schedule			
Colour	Dutch	English	Deutsch
Rd	Rood	Red	Rot
Bl	Blauw	Blue	Blau
Gl	Geel	Yellow	Gelb
Gn	Groen	Green	Gruen
Zw	Zwart	Black	Schwarz
Wt	Wit	White	Weiss
Bn	Bruin	Brown	Braun
Rs	Roze	Pink	Rosa
Or	Oranje	Orange	Orange
Ps	Paars	Violet	Violett
Tp	Transp.	Transp.	Transp.
Gs	Grijs	Grey	Grau

		X4				X1				OPT. <SMSY>																
		2	4	5	7	14					31	32	33	37	38	38	38	39	40	41	42					
1	23						F1F 20A															15	152			
		17	3	18	22		F2F 20A																5A	53	54	
							F3F 5A																			
							F4F 5A																			
							F5F 5A																			
1	23	17	3	18	22		F1F 20A																		15	152
							F2F 20A																			
							F3F 5A																			
							F4F 5A																			
							F5F 5A																			

AANSluiting OP PLATFORM
ANSCHLUSS AUF PLATTFORM
CONNECTION ON PLATFORM

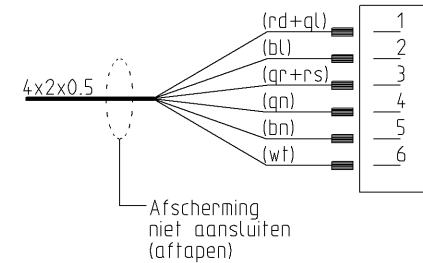

this drawing is property of Holland Lift International, by all rights reserved
 deze tekening is eigendom van Holland Lift International, by all rights reserved
 deze tekening is eigendom van Holland Lift International, by all rights reserved

KLEMMENKAST
KLEMMENKASTEN
CONNECTION BOX

WARTEL KABELEINF. GLAND NR.	KLEM KLEMME TERMINAL NR.	FUNKTIE	FUNKTION	FUNCTION
1.1	φ 1	Voeding +24V	Speisung +24V	Power Supply +24V
1.2	GND	Voeding GND	Speisung GND	Power Supply GND
1.3	φ 23	+ Generator	+ Generator	+ Generator
2.1	DIV/VAR	Frame Dieselmotor	Frame Dieselmotor	Frame Diesel Engine
2.2	φ 38 -GND-X4	Scheefstand	Neigung	Inclination
2.3	φ 38 -GND-X5	Scheefstand Opt.	Neigung Opt.	Inclination Opt.
3.1	φ 38 -X0	2,5mtr. Afslag S1Q	2,5mtr. Ausschaltung S1Q	2,5mtr. Cut-out S1Q
3.2	DIV/VAR	4,5mtr. Afslag S2Q	4,5mtr. Ausschaltung S2Q	4,5mtr. Cut-out S2Q
4.1	φ 38 -X2	Max. Hoogte Afslag S3Q	Max. Hoehe Ausschaltung S3Q	Max. Height Cut-out S3Q
4.2	Y2-GND	Dalen	Senken	Lift Down
4.3	DIV/VAR	2e hoogte Afslag Optie	2e hoehe Ausschaltung Option	2nd height cut-out Opt.
5.1	Y0-Y1-GND	Dalen Opt./Heffen	Senken Opt./Heben	Lift Down Opt./Lift Up
5.2	φ 39 -X1.4	Tank leeg	Tank leer	Tank empty
5.3	φ 39 -X1.6	Temp. Hd. Olie	Temp. Hd. Oel	Temp. Hd. Oil
6	DIV/VAR	Diesel	Diesel	Diesel
7.1	DIV/VAR	Rups Links Vooruit/Achteruit	Raupe Links Vor./Rueck.	Track Left For./Rev.
7.2	DIV/VAR	Rups Rechts Vooruit/Achteruit	Raupe Rechts Vor./Rueck.	Track Right For./Rev.
8.1	Y3-GND	Zwaailamp Opt.	Blitzleuchte Opt.	Flashlight Opt.
8.2	Y3-GND	Zwaailamp Opt.	Blitzleuchte Opt.	Flashlight Opt.
9.1	φ 41 -φ 42 -GND	Vlakstellen omhoog/omlaag	Nivellierung hinauf/hinunter	Leveling up/down
9.2	DIV/VAR	HD Koeler Opt.	HD Kuehler Opt.	HD Cooler Opt.
10.1	φ 41 -GND	2/2 Ventiel omlaag	2/2 Ventil hinunter	2/2 Valve down
10.2	φ 41 -GND	2/2 Ventiel omlaag	2/2 Ventil hinunter	2/2 Valve down
11.1	φ 42 -GND	2/2 Ventiel omhoog	2/2 Ventil hinauf	2/2 Valve up
11.2	φ 42 -GND	2/2 Ventiel omhoog	2/2 Ventil hinauf	2/2 Valve up
12	DIV/VAR	Aanst. 6P Platform	Anschl. 6P Plattform	Conn. 6P Platform
13.1	DIV/VAR	Druk Meting	Druck Messung	Pressure Measuring
13.2	DIV/VAR	Hoekmeting	Winkel Messung	Angle Measuring
14.1	Y1.9-GND	Relais Aggregaat Opt.	Relais Aggr. Opt.	Relais Aggr. Opt.
14.2	Y1.8-GND	Hydr. Aggregaat Opt.	Hydr. Aggr. Opt.	Hydr. Aggr. Opt.
15.1	DIV/VAR	Smeersysteem Opt.	Schmiere System Opt.	Grease System Opt.
15.2	DIV/VAR	Black-Box Opt.	Black-Box Opt.	Black-Box Opt.

this drawing is property of Holland Lift International, by all rights reserved
 deze tekening is eigendom van Holland Lift International, by all rights reserved
 deze tekening is eigendom van Holland Lift International, by all rights reserved

HOLLAND LIFT

Holland Lift International B.V.
Anodeweg 1
NL-1627 LJ Hoorn The Netherlands
T/F +31 (0)229-285555 / 285550
E service@hollandlift.com
W www.hollandlift.com

KASTEN/BEKABELING
KASTEN/KABEL
BOXES/CABLES

Projekt:
EX-20-001

Zeichnungsnummer:

Rev.: A

erstellt von:
Rothenbusch

Datum:
05.05.2017

Antage:

Ort: +

Blatt:
22

BEDIENINGSKAST STEUERPULT CONTROL BOX

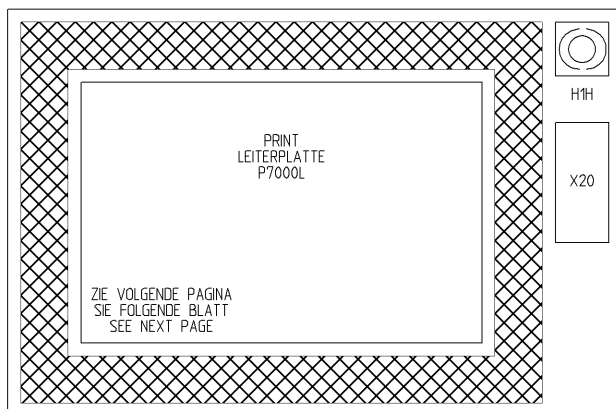
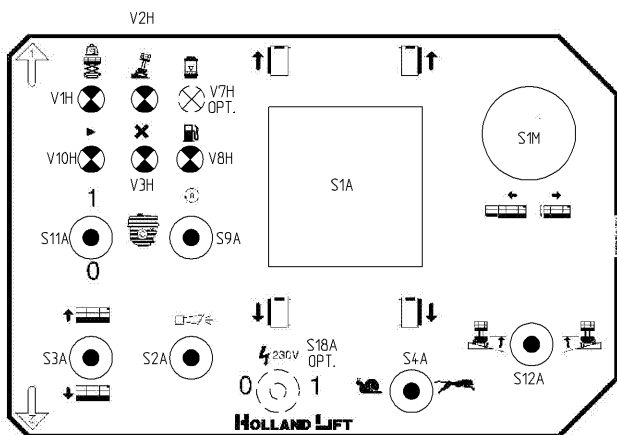

Colour schedule			
Colour	Dutch	English	Deutsch
Rd	Rood	Red	Rot
Bl	Blauw	Blue	Blau
Gl	Geel	Yellow	Gelb
Gn	Groen	Green	Gruen
Zw	Zwart	Black	Schwarz
Wt	Wit	White	Weiss
Bn	Bruin	Brown	Braun
Rs	Roze	Pink	Rosa
Or	Oranje	Orange	Orange
Ps	Poars	Violet	Violett
Tp	Transp.	Transp.	Transp.
Gs	Grijs	Grey	Grau

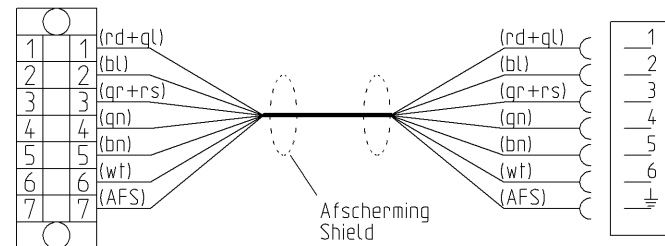
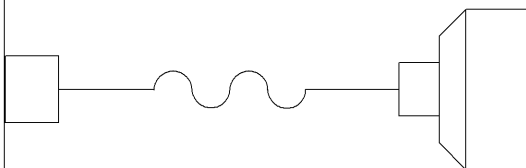

this drawing is property of Holland Lift International, by all rights reserved
 deze tekening is eigendom van Holland Lift International, by auteursrecht voorbehouden volgens de wet
 deze tekening is eigendom van Holland Lift International, by auteursrecht voorbehouden volgens de wet

HOLLAND LIFT

Holland Lift International B.V.
 Anodeweg 1
 NL-1627 LJ Hoorn The Netherlands
 T/F +31 (0)229-285555 / 285550
 E service@hollandlift.com
 W www.hollandlift.com

KASTEN/BEKABELING
 KASTEN/KABEL
 BOXES/CABLES

Projekt: EX-20-001

Zeichnungsnummer:

Rev.: A

erstellt von:
 Rothenbusch

Datum: 05.05.2017

Anlage: =

Ort: +

Blatt: 23

PRINTPLAAT
LEITERPLATTE
CIRCUIT BOARD

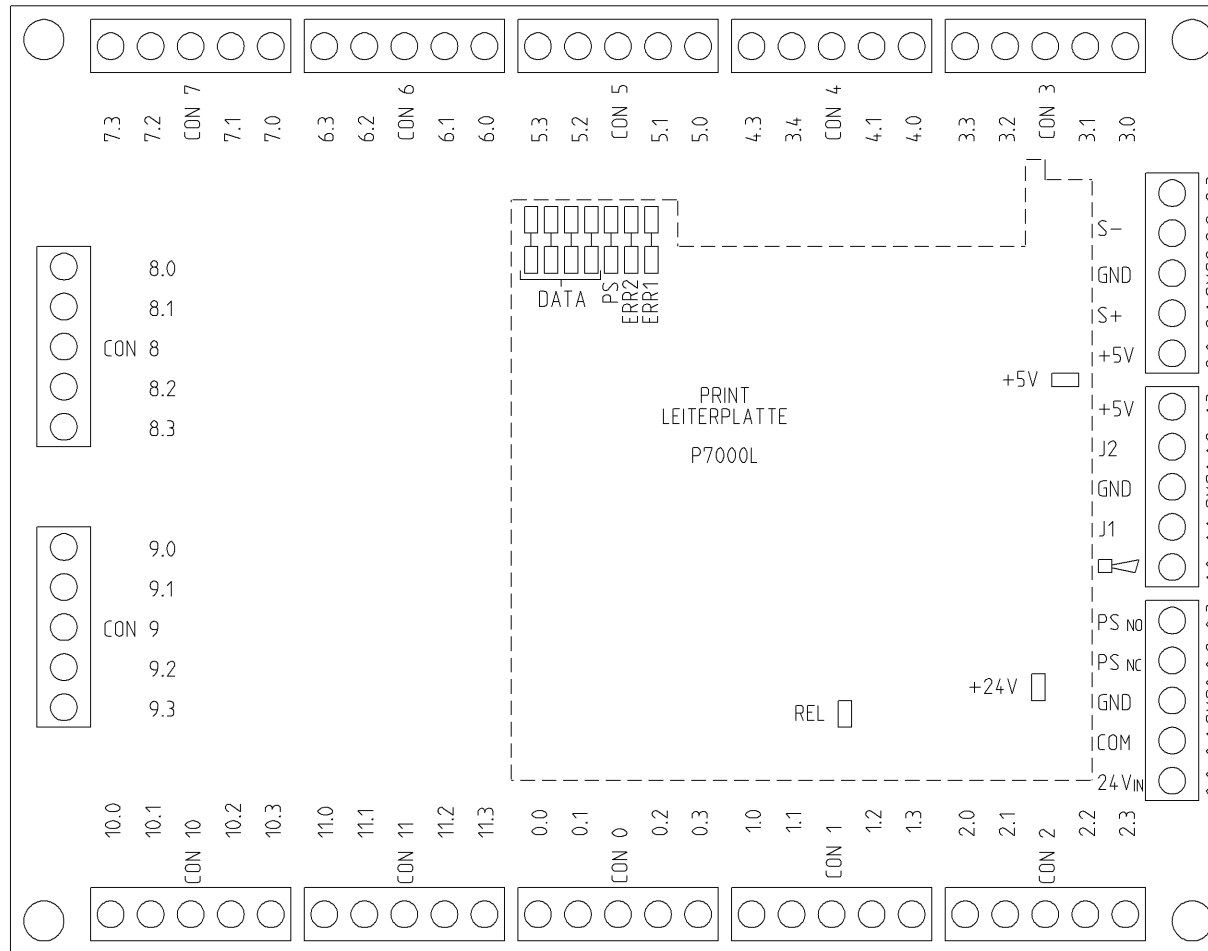

+24V	<input type="checkbox"/>	Groen/Gruen/Green	Voeding Ok	Speisung Ok	Supply Ok
+5V	<input type="checkbox"/>	Groen/Gruen/Green	Voeding Ok	Speisung Ok	Supply Ok
REL	<input type="checkbox"/>	Groen/Gruen/Green	Power Safe aan	Power Safe an	Power Safe on
PS	<input type="checkbox"/>	Geel/Gelb/Yellow	Power Safe uit	Power Safe aus	Power Safe off
Err1	<input type="checkbox"/>	Geel/Gelb/Yellow	Slechte Data Verbinding	Schlechte Data Verbindung	Poor Data Connection
Err2	<input type="checkbox"/>	Rood/Rot/Red	Geen Data Verbinding	Keine Data Verbindung	No Data Connection

this drawing is property of Holland Lift International, by all rights reserved.
 diese zeichnung ist eigentum von Holland Lift International, by all rights reserved.
 deze tekening is eigendom van Holland Lift International, by auteursrecht voorbehouden volgens de wet

HOLLAND LIFT

Holland Lift International B.V.
 Anodeweg 1
 NL-1627 LJ Hoorn The Netherlands
 T/F +31 (0)229-285555 / 285550
 E service@hollandlift.com
 W www.hollandlift.com

PRINTPLAAT
LEITERPLATTE
CIRCUIT BOARD

Projekt: EX-20-001

Zeichnungsnummer:

Rev.: A

erstellt von:
Rothenbusch

Datum: 05.05.2017

Anlage:

Ort: +

Blatt: 24

this drawing is property of Holland Lift International, by all rights reserved
 deze tekening is eigendom van Holland Lift International, by all rights reserved
 deze tekening is eigendom van Holland Lift International, by auteursrecht voorbehouden volgens de wet

0.0	Rups Li. Voor. (S1A3)	Raupe Li. Vor. (S1A3)	Track Left For. (S1A3)
0.1	Rups Li. Achter. (S1A4)	Raupe Li. Rueck. (S1A4)	Track Left Rev. (S1A4)
CON 0			
0.2	Rups Re. Voor. (S1A5)	Raupe Re. Vor. (S1A5)	Track Ri. For. (S1A5)
0.3	Rups Re. Achter (S1A6)	Raupe Re. Rueck. (S1A6)	Track Ri. Rev. (S1A6)

1.0	Claxon (S2A1)	Hupe (S2A1)	Horn (S2A1)
1.1	Reserve	Reserve	Spare
CON 1			
1.2	Heffen (S3A1)	Heben (S3A1)	Lift Up (S3A1)
1.3	Dalen (S3A3)	Senken (S3A3)	Lift Down (S3A3)

2.0	Snel Rijden (S4A1)	Schnell Fahren (S4A1)	Driving Fast (S4A1)
2.1	Toerental (S9A)	Drehzahl (S9A)	Enging Speed (S9A)
CON 2			
2.2	Langzaam Rij. (S4A3)	Langsam Fahren (S4A3)	Driving Slow (S4A3)
2.3	Reserve	Reserve	Spare

0.0	Voeding +24V (S1M)	Speisung +24V (S1M)	Supply +24V (S1M)
0.1	Voeding +24V (S1M)	Speisung +24V (S1M)	Supply +24V (S1M)
SYS0 GND	GND	GND	GND
0.2	Reserve	Reserve	Spare
0.3	Voeding +24V (PS)	Speisung +24V (PS)	Supply +24V (PS)

1.0	+ Zoemer (H1H)	+ Summer (H1H)	+ Buzzer (H1H)
1.1	0-5V Joystick P1	0-5V Joystick P1	0-5V Joystick P1
SYS1 GND	- Zoemer (H1H)	- Summer (H1H)	- Buzzer (H1H)
1.2	0-5V Joystick P2	0-5V Joystick P2	0-5V Joystick P2
1.3	Voeding +5V Joy.	Speisung +5V Joy.	Supply +5V Joy.

2.0	Reserve	Reserve	Spare
2.1	Data S+ (RS485)	Data S+ (RS485)	Data S+ (RS485)
SYS2 GND	Reserve	Reserve	Spare
2.2	Data S- (RS485)	Data S- (RS485)	Data S- (RS485)
2.3	Reserve	Reserve	Spare

3.0	Dodemansknopt (S1A1)	Totmansknopt (S1A1)	Dead Man (S1A1)
3.1	Dodemansknopt (S1A2)	Totmansknopt (S1A2)	Dead Man (S1A2)
CON 3			
3.2	Vlak. omhoog (S12A1)	Nivel. hinauf (S12A1)	Lev. up (S12A1)
3.3	Vlak. omlaag (S12A3)	Nivel. hinunter (S12A3)	Lev. down (S12A3)

4.0	Reserve	Reserve	Spare
4.1	Reserve	Reserve	Spare
CON 4			
4.2	Reserve	Reserve	Spare
4.3	Reserve	Reserve	Spare

5.0	Vetpomp (V7H) Opt.	Fett Pumpe (V7H) Opt.	Grease Pu. (V7H) Opt.
5.1	Overload (V1H)	Ueberlastung (V1H)	Overload (V1H)
CON 5			
5.2	Scheefstand (V2H)	Neigung (V2H)	Inclination (V2H)
5.3	Tank leeg (V8H)	Tank leer (V8H)	Tank empty (V8H)

6.0	Start Motor (S11A1)	Start Motor (S11A1)	Start Engine (S11A1)
6.1	Stop Motor (S11A3)	Halt Motor (S11A3)	Stop Engine (S11A3)
CON 6			
6.2	Gen. aan Opt. (S18A1)	Gen. an Opt. (S18A1)	Gen. on Opt. (S18A1)
6.3	Gen. uit Opt. (S18A3)	Gen. aus Opt. (S18A3)	Gen. off Opt. (S18A3)

7.0	Reserve	Reserve	Spare
7.1	Reserve	Reserve	Spare
CON 7			
7.2	Reserve	Reserve	Spare
7.3	Reserve	Reserve	Spare

8.0	Reserve	Reserve	Spare
8.1	Reserve	Reserve	Spare
CON 8			
8.2	Reserve	Reserve	Spare
8.3	Reserve	Reserve	Spare

9.0	Reserve	Reserve	Spare
9.1	Reserve	Reserve	Spare
CON 9			
9.2	Reserve	Reserve	Spare
9.3	Reserve	Reserve	Spare

10.0	In Bedrijf (V10H)	In Betrieb (V10H)	Run (V10H)
10.1	Storing Dieselm. (V3H)	Stoerung Dieselm. (V3H)	Failure Dieselm. (V3H)
CON 10			
10.2	Reserve	Reserve	Spare
10.3	Reserve	Reserve	Spare

11.0	Reserve	Reserve	Spare
11.1	Reserve	Reserve	Spare
CON 11			
11.2	Reserve	Reserve	Spare
11.3	Reserve	Reserve	Spare



Holland Lift International B.V.
 Anodeweg 1
 NL-1627 LJ Hoorn The Netherlands
 T/F +31 (0)229-285555 / 285550
 E service@hollandlift.com
 W www.hollandlift.com

PRINTPLAAT
 LEITERPLATTE
 CIRCUIT BOARD

Projekt:	EX-20-001	Zeichnungsnummer:	Rev.:	A	erstelt von:	Rothenbusch	
Datum:	05.05.2017	Antlage:	=	Ort:	+	Blatt:	25