

AANSLUITKLEM KLEMMENKAST  
 φ ANSCHLUSSKLEMME KLEMMKASTEN  
 TERMINAL CONNECTION BOX  
  
 AANSLUITKLEM BEDIENINGSKAST  
 φ ANSCHLUSSKLEMME STEUERPULT  
 TERMINAL CONTROL BOX

AANSLUITKLEM TRANSISTOR  
 ⊕ ANSCHLUSSKLEMME TRANSISTOR  
 TERMINAL TRANSISTOR  
  
 AANSLUITKLEM PLC  
 ⊕ ANSCHLUSSKLEMME SPS  
 TERMINAL PLC

AANSLUITKLEM PLC-SLAVE  
 φ ANSCHLUSSKLEMME SPS-SLAVE  
 TERMINAL PLC-SLAVE

| TYPE        |                        | OMSCHRIJVING<br>UMSCHREIBUNG<br>DESCRIPTION | PLC PROG:<br>SPS PROG:<br>PLC PROG: |
|-------------|------------------------|---|-------------------------------------|
| Y-70DU12-TR |                        | FPX   | Y-D-TR-02A                          |
|             |                        |   |                                     |
|             |                        |   |                                     |
|             |                        |   |                                     |
|             |                        |   |                                     |
|             |                        |   |                                     |
|             |                        |   |                                     |
|             |                        |   |                                     |
|             |                        |   |                                     |
|             |                        |   |                                     |
|             |                        |   |                                     |
|             |                        |   |                                     |
|             |                        |   |                                     |
| REV.        | DATUM<br>DATUM<br>DATE | OPMERKING<br>BEMERKUNG<br>REMARK            |                                     |
| -           | 10-04-12               | DIV. AANPASSINGEN                           |                                     |
|             |                        |   |                                     |
|             |                        |   |                                     |
|             |                        |   |                                     |
|             |                        |   |                                     |

This drawing is property of Holland Lift International. By all rights reserved.  
 diese Zeichnung ist Eigentum von Holland Lift International. By all rights reserved.  
 deze tekening is eigendom van Holland Lift International. By auteursrecht voorbehouden volgens de wet



Holland Lift International B.V.  
 Anodeweg 1  
 NL-1627 LJ Haarn The Netherlands  
 T/F +31 (0)229-285555 / 285550  
 E service@hollandlift.com  
 W www.hollandlift.com

INDEX BLAD  
 INDEX BLATT  
 INDEX SHEET

|                       |                   |           |                              |
|-----------------------|-------------------|-----------|------------------------------|
| Projekt:<br>EY-20-001 | Zeichnungsnummer: | Rev.:     | erstellt von:<br>Rothenbusch |
| Datum:<br>10.04.2012  | Anlage:<br>=      | Ort:<br>+ | Blatt:<br>1                  |

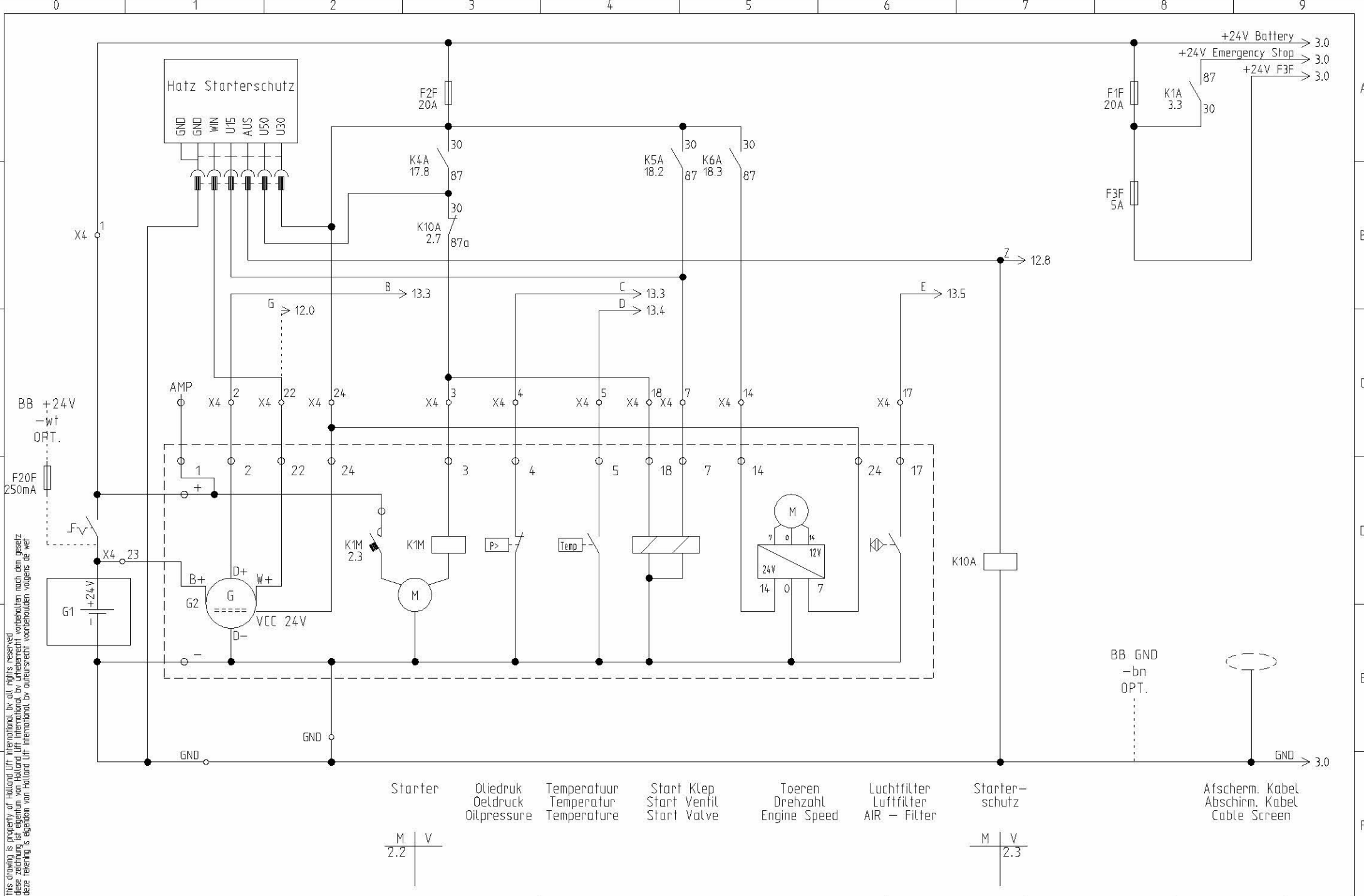

this drawing is property of Holland Lift International, by all rights reserved.  
 deze tekening is eigendom van Holland Lift International, by all rights reserved.  
 deze tekening is eigendom van Holland Lift International, by all rights reserved.

- Starter
- Oliedruk  
Oilpressure
- Temperatuur  
Temperature
- Start Klep  
Start Valve
- Toeren  
Engine Speed
- Luchtfilter  
AIR - Filter
- Starter-  
schutz
- Afscherm. Kabel  
Abschirm. Kabel  
Cable Screen

M | V  
2.2

M | V  
2.3



Holland Lift International B.V.  
 Anadeweg 1  
 NL-1627 LJ Haarn The Netherlands  
 T/F +31 (0)229-285555 / 285550  
 E service@hollandlift.com  
 W www.hollandlift.com

Dieselmotor

Projekt: EY-20-001  
 Datum: 10.04.2012

Zeichnungsnummer:  
 Anlage: =

Rev.:  
 Ort: +

erstelt von:  
 Rothenbusch  
 Blatt: 2

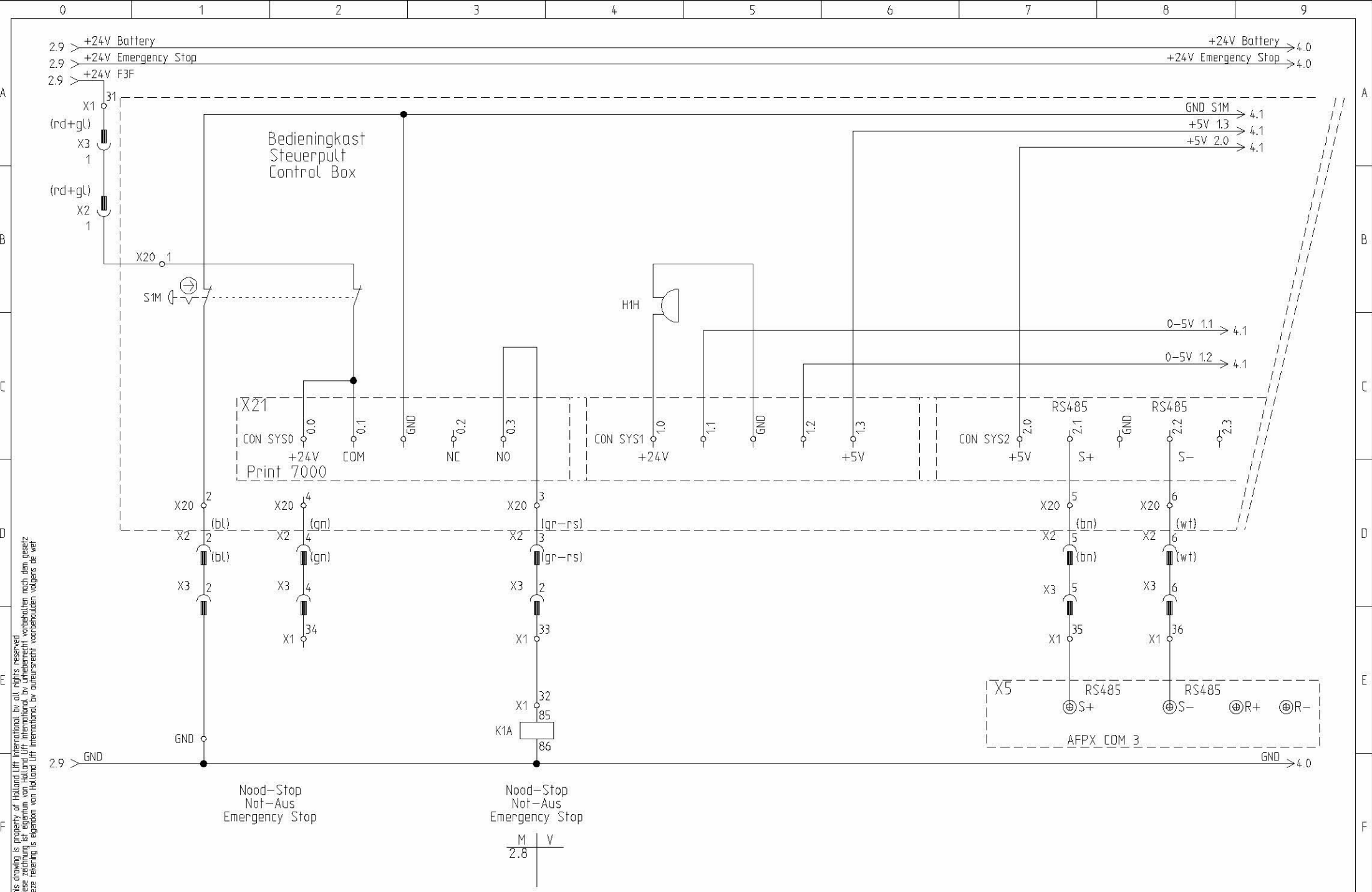

This drawing is property of Holland Lift International. All rights reserved.  
 deze tekening is eigendom van Holland Lift International. Het auteursrecht voorbehouden volgens de wet.

0 1 2 3 4 5 6 7 8 9  
 3.9 > +24V Battery  
 3.9 > +24V Emergency Stop  
 +24V Battery > 5.0  
 +24V Emergency Stop > 5.0

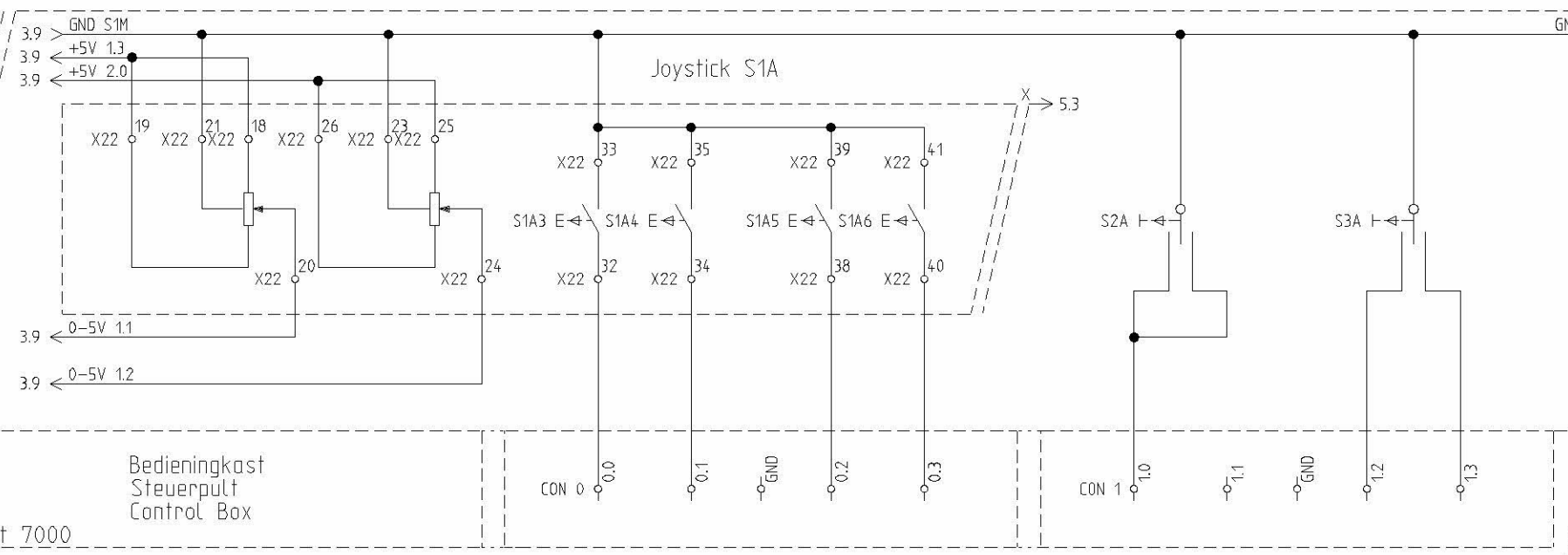

Bedieningkast  
 Steuerpult  
 Control Box  
 X21 Print 7000  
 CON 0 0.0 0.1 GND 0.2 0.3  
 CON 1 1.0 1.1 GND 1.2 1.3  
 3.9 > GND  
 GND > 5.0

Rups Links  
 Raupe Links  
 Track Left

Rups Rechts  
 Raupe Rechts  
 Track Right

Voruit – Achteruit  
 Vorw. – Rueckw.  
 Forward – Reverse

Voruit – Achteruit  
 Vorw. – Rueckw.  
 Forward – Reverse

Rups Links  
 Raupe Links  
 Track Left

Rups Rechts  
 Raupe Rechts  
 Track Right

Claxon-Sign.gever  
 Hupe-Signalgeber  
 Horn-Signal

Heffen  
 Heben  
 Lift Up

Dalen  
 Senken  
 Lift Down

this drawing is property of Holland Lift International, by all rights reserved  
 diese zeichnung ist eigentum von Holland Lift International, by all rights reserved  
 deze tekening is eigendom van Holland Lift International, by auteursrecht voorbehouden volgens de wet



Holland Lift International B.V.  
 Anadeweg 1  
 NL-1627 LJ Haarn The Netherlands  
 T/F +31 (0)229-285555 / 285550  
 E service@hollandlift.com  
 W www.hollandlift.com

Bedienpult  
 CON 0 - 1

|                       |                   |           |                              |
|-----------------------|-------------------|-----------|------------------------------|
| Projekt:<br>EY-20-001 | Zeichnungsnummer: | Rev.:     | erstellt von:<br>Rothenbusch |
| Datum:<br>10.04.2012  | Anlage:<br>=      | Ort:<br>+ | Blatt:<br>4                  |

4.9 > +24V Battery  
 4.9 > +24V Emergency Stop

+24V Battery > 6.0  
 +24V Emergency Stop > 6.0

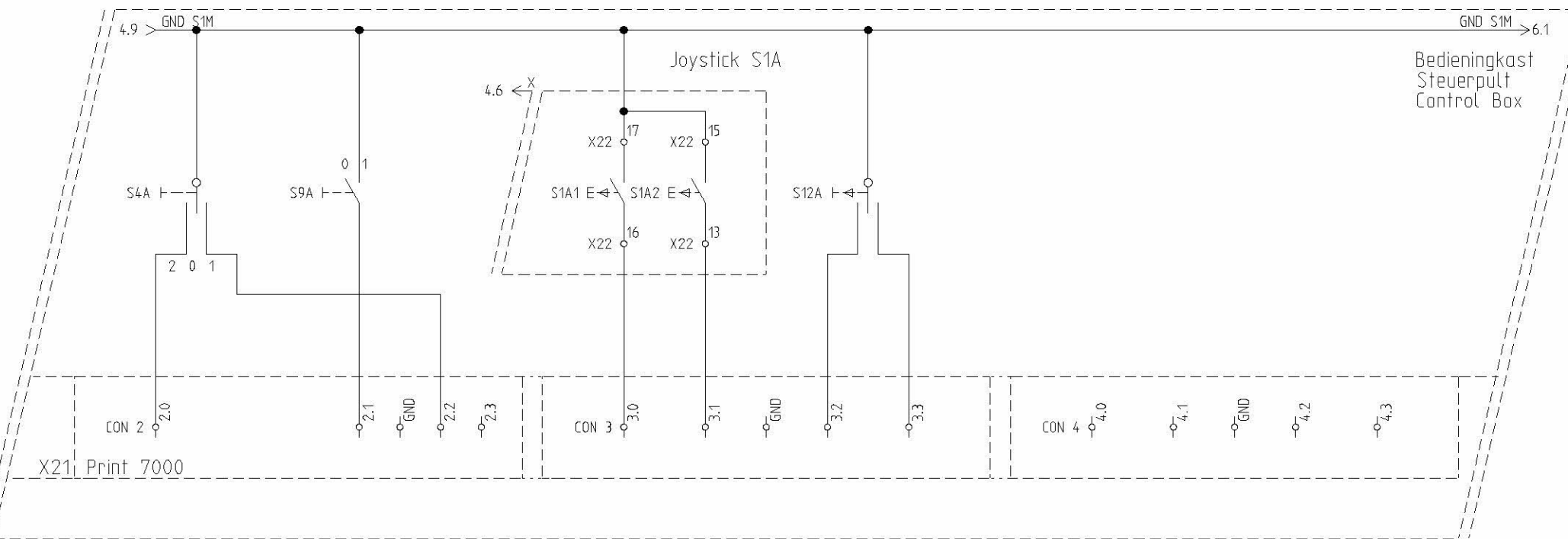

S4A

|   |   |          |         |        |
|---|---|----------|---------|--------|
| 0 | = | Langzaam | Langsam | Slow   |
| 1 | = | Normaal  | Normal  | Normal |
| 2 | = | Snel     | Schnell | Fast   |

S9A

|   |   |        |         |        |
|---|---|--------|---------|--------|
| 0 | = | Laag   | Niedrig | Low    |
| 1 | = | Autom. | Autom.  | Autom. |

4.9 > GND

GND > 6.0

Snelheid  
 Geschwindigkeit  
 Speed

Toerental  
 Drehzahl  
 Enging Speed

S1A1/S1A2 Dodemansknop  
 S1A1/S1A2 Totmansknopf  
 S1A1/S1A2 Dead Man,s Button

Vlakstellen  
 Nivellierung  
 Leveling



This drawing is property of Holland Lift International. By all rights reserved.  
 deze tekening is eigendom van Holland Lift International. Bij auteursrecht voorbehouden volgens de wet.  
 deze tekening is eigendom van Holland Lift International. Bij auteursrecht voorbehouden volgens de wet.

5.9 > +24V Battery  
 5.9 > +24V Emergency Stop

+24V Battery > 7.0  
 +24V Emergency Stop > 7.0

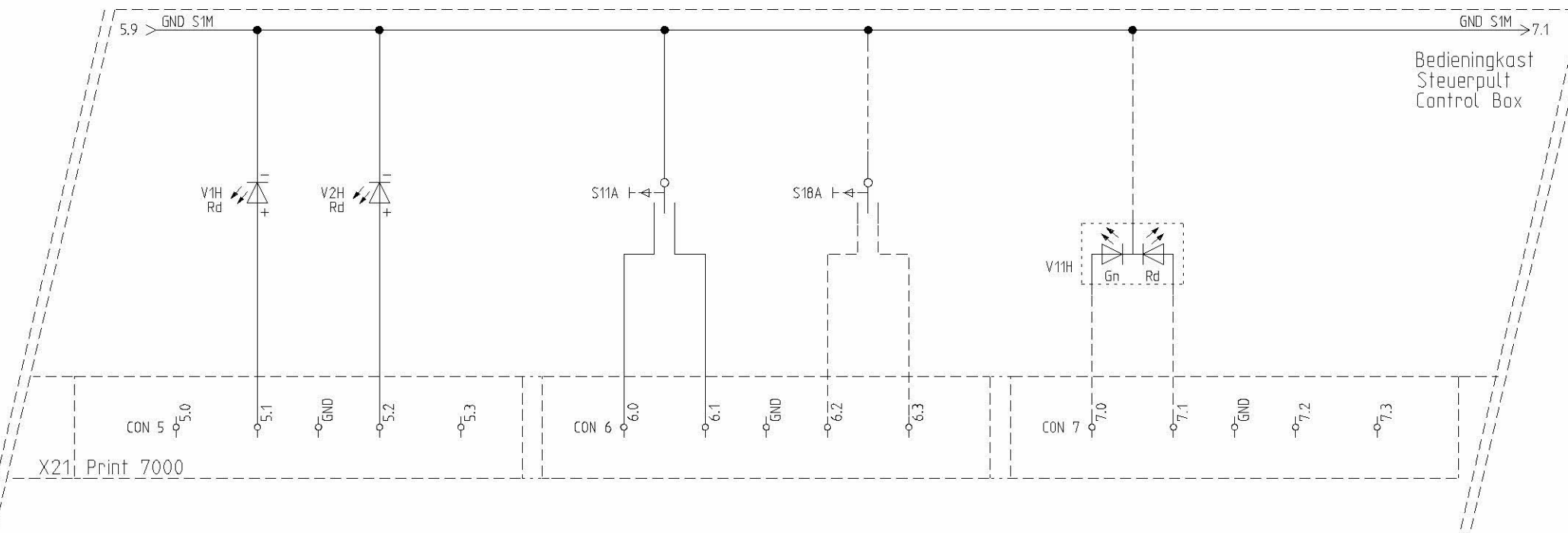

Bedieningkast  
 Steuerpult  
 Control Box

X21, Print 7000

5.9 > GND GND > 7.0

Overload Ueberlastung  
 Scheefstand Neigung  
 Overload Grade/Slope

Start - Motor - Stop  
 Start - Motor - Halt  
 Start - Engine - Stop

Aan Generator Uit  
 An Generator Aus  
 On Generator Off

Ok Fout  
 Ok Falsch  
 Ok Fault

Optie/Option

Niv. Platform/Niv. Plattform

Optie/Option

this drawing is property of Holland Lift International, by all rights reserved  
 deze tekening is eigendom van Holland Lift International, by all rights reserved  
 deze tekening is eigendom van Holland Lift International, by all rights reserved



Holland Lift International B.V.  
 Anodeweg 1  
 NL-1627 LJ Haarn The Netherlands  
 T/F +31 (0)229-285555 / 285550  
 E service@hollandlift.com  
 W www.hollandlift.com

Bedienpult  
 CON 5 - 7

|                       |                   |           |                              |
|-----------------------|-------------------|-----------|------------------------------|
| Projekt:<br>EY-20-001 | Zeichnungsnummer: | Rev.:     | erstellt von:<br>Rothenbusch |
| Datum:<br>10.04.2012  | Anlage:<br>=      | Ort:<br>+ | Blatt:<br>6                  |

6.9 > +24V Battery  
 6.9 > +24V Emergency Stop

+24V Battery > 8.0  
 +24V Emergency Stop > 8.0

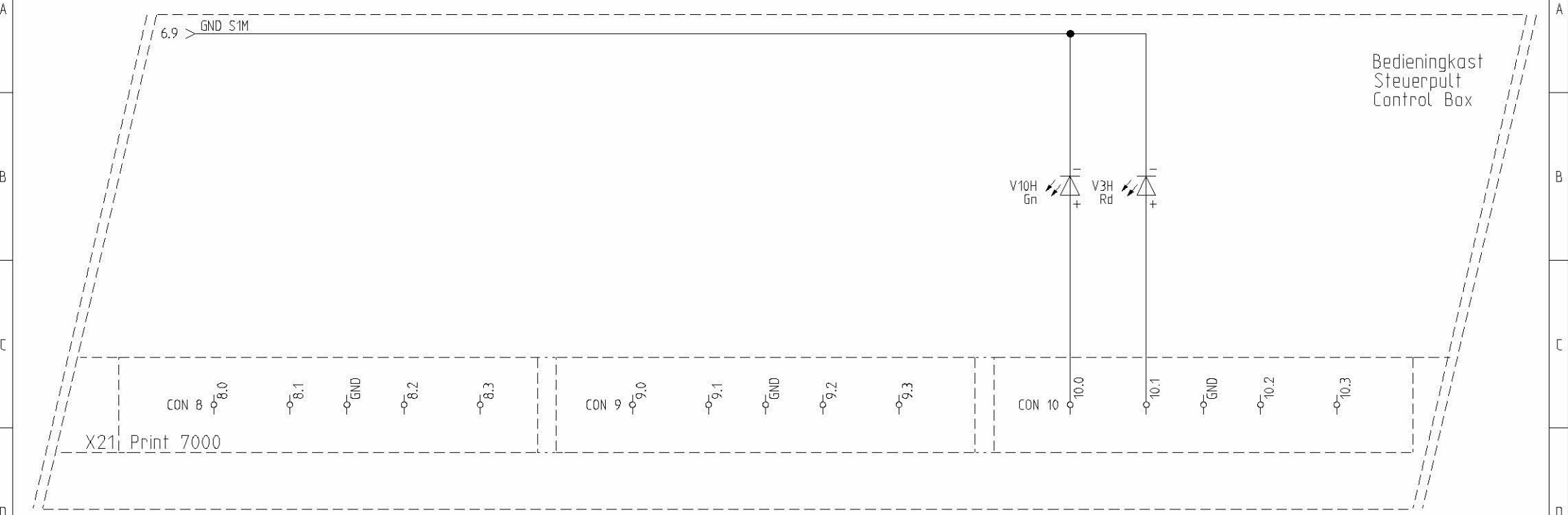

6.9 > GND

GND > 8.0

In Bedrijf Storing  
 In Betrieb Stoerung  
 Run Failure

Diesel Motor

This drawing is property of Holland Lift International. By all rights reserved.  
 deze tekening is eigendom van Holland Lift International. Bij auteursrecht voorbehouden volgens de wet.  
 deze tekening is eigendom van Holland Lift International. Bij auteursrecht voorbehouden volgens de wet.



Holland Lift International B.V.  
 Anodeweg 1  
 NL-1627 LJ Haarn The Netherlands  
 T/F +31 (0)229-285555 / 285550  
 E service@hollandlift.com  
 W www.hollandlift.com

Bedienpult  
 CON 8 - 10

|                       |                   |           |                              |
|-----------------------|-------------------|-----------|------------------------------|
| Projekt:<br>EY-20-001 | Zeichnungsnummer: | Rev.:     | erstellt von:<br>Rothenbusch |
| Datum:<br>10.04.2012  | Anlage:<br>=      | Ort:<br>+ | Blatt:<br>7                  |

7.9 > +24V Battery  
 7.9 > +24V Emergency Stop

+24V Battery > 9.0  
 +24V Emergency Stop > 9.0

Bedieningkast  
 Steuerpult  
 Control Box

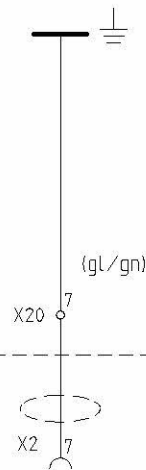
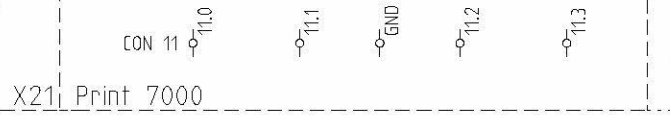

7.9 > GND

GND > 9.0

This drawing is property of Holland Lift International. By all rights reserved.  
 deze tekening is eigendom van Holland Lift International. Bij auteursrecht voorbehouden volgens de wet.  
 deze tekening is eigendom van Holland Lift International. Bij auteursrecht voorbehouden volgens de wet.

# HOLLAND LIFT

Holland Lift International B.V.  
 Anodeweg 1  
 NL-1627 LJ Haarn The Netherlands  
 T/F +31 (0)229-285555 / 285550  
 E service@hollandlift.com  
 W www.hollandlift.com

Bedienpult  
 CON 11

Projekt:  
 EY-20-001

Zeichnungsnummer:

Rev.:

erstellt von:  
 Rothenbusch

Datum:  
 10.04.2012

Anlage:

Ort:  
 = +

Blatt:  
 8



This drawing is property of Holland Lift International. By all rights reserved.  
 deze tekening is eigendom van Holland Lift International. By all rights reserved.  
 deze tekening is eigendom van Holland Lift International. By all rights reserved.

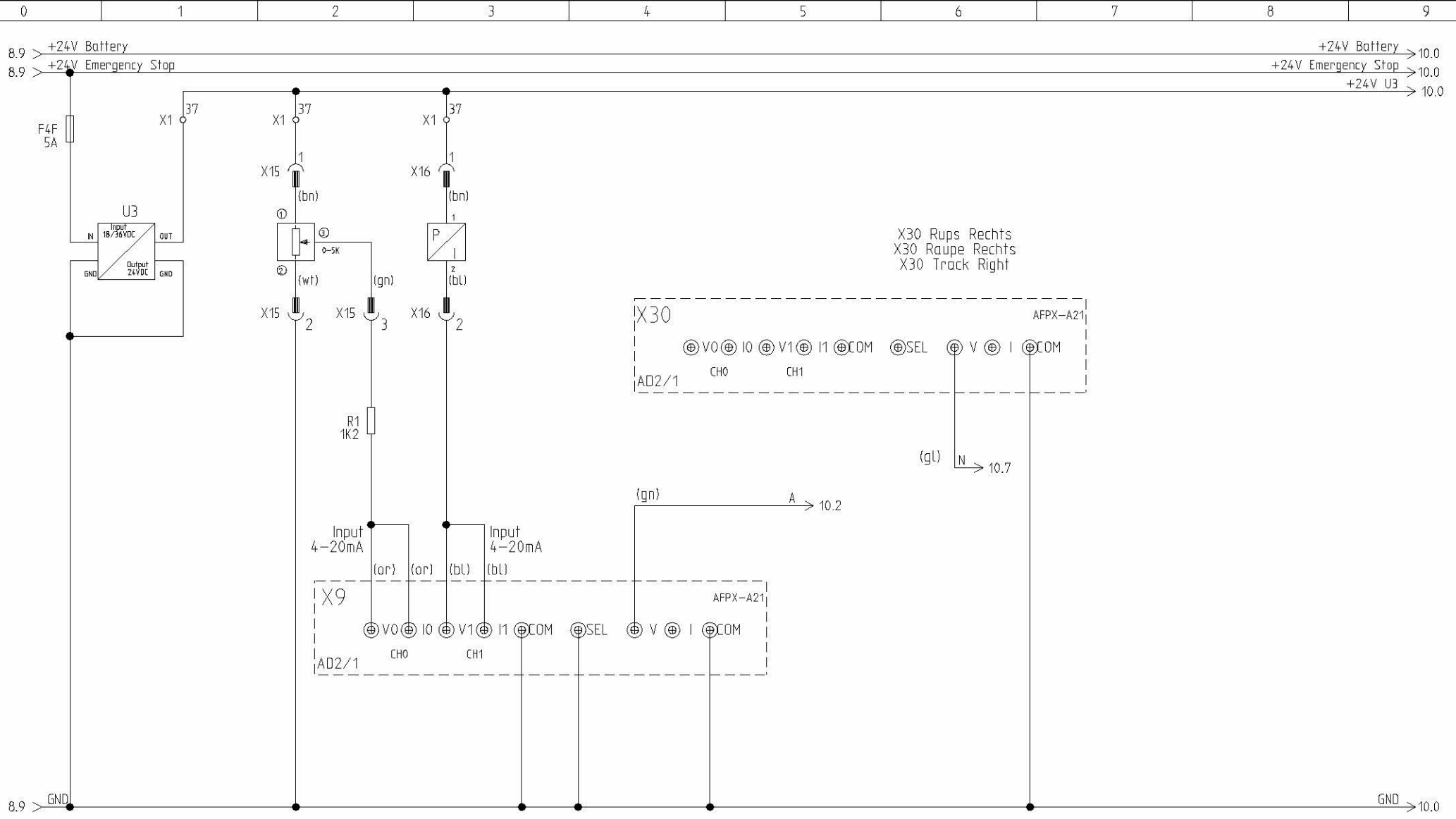

Hoekmeting  
Winkel Messung  
Angel Measuring

Druk Meting  
Druck Messung  
Pressure Measuring

X9 Rups Links  
X9 Raupe Links  
X9 Track Left

X30 Rups Rechts  
X30 Raupe Rechts  
X30 Track Right

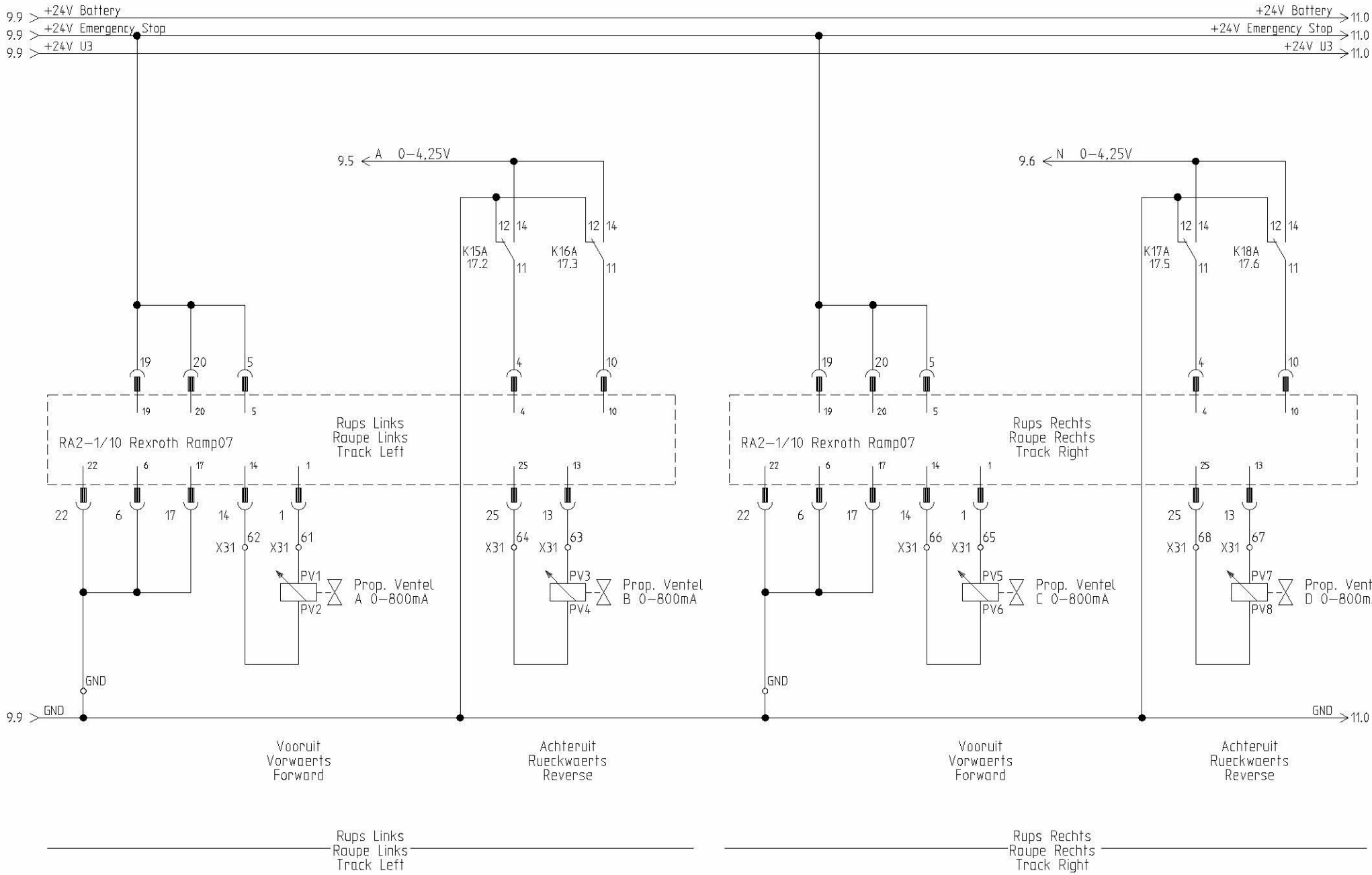

This drawing is property of Holland Lift International. By all rights reserved.  
 deze tekening is eigendom van Holland Lift International. Bij auteursrecht voorbehouden volgens de wet.  
 this drawing is property of Holland Lift International. By all rights reserved.  
 diese zeichnung ist Eigentum von Holland Lift International. Bei Urheberrecht vorbehalten nach dem Gesetz.  
 deze tekening is eigendom van Holland Lift International. Bij auteursrecht voorbehouden volgens de wet.

This drawing is property of Holland Lift International. By all rights reserved.  
 deze tekening is eigendom van Holland Lift International. By auteursrecht voorbehouden volgens de wet.  
 deze tekening is eigendom van Holland Lift International. By auteursrecht voorbehouden volgens de wet.

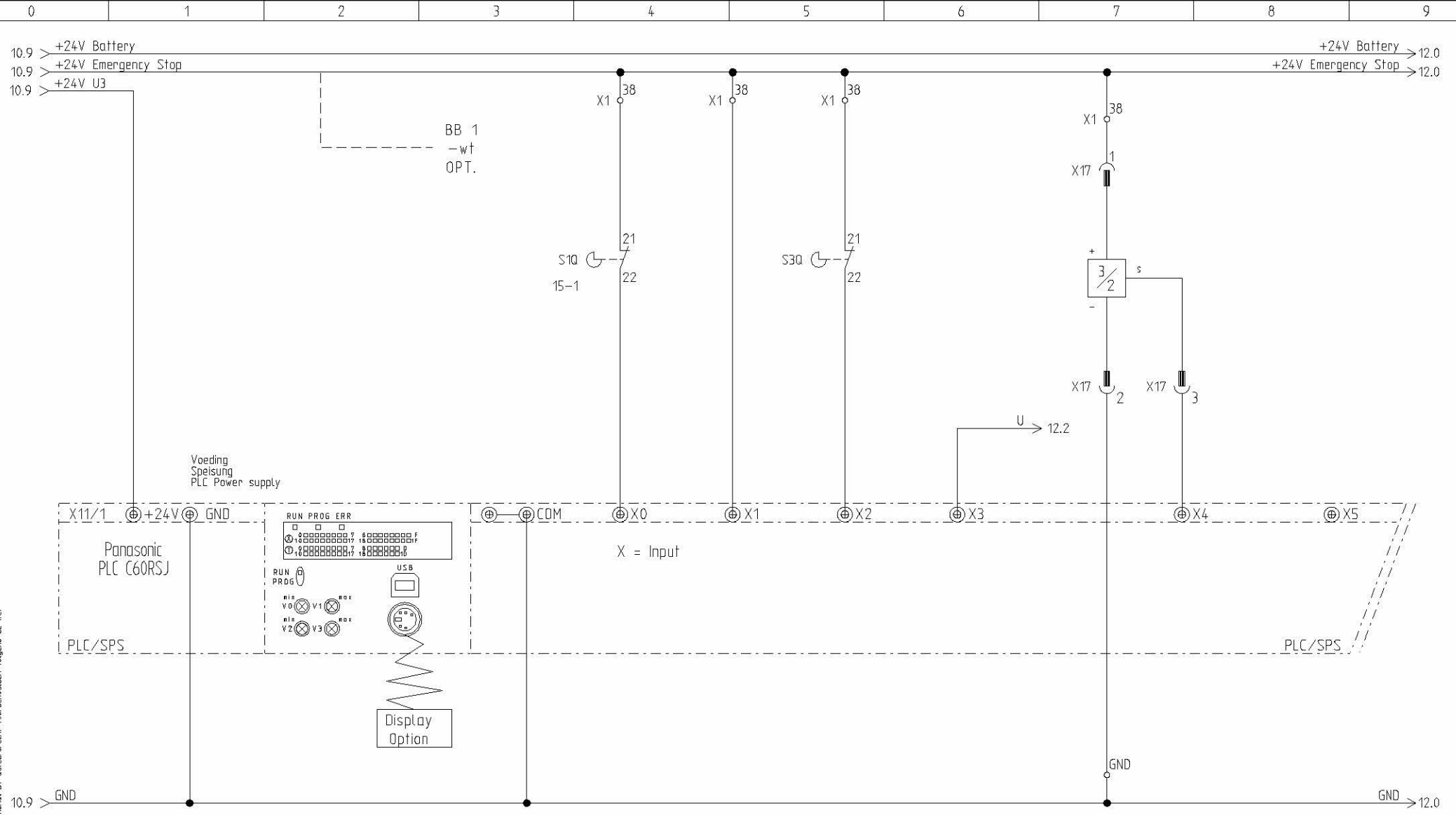

2,5 mtr. Afslag  
 2,5 mtr. Ausschalt.  
 2,5 mtr. Cut-Out

Max. Hogte Dalen Onderwagen  
 Max. Hoehe Senken Chassis  
 Max. Height Lift Down Chassis

Scheefstand 3/2  
 Neigung 3/2  
 Grade/Slope 3/2

Reserve  
 Reserve  
 Spare

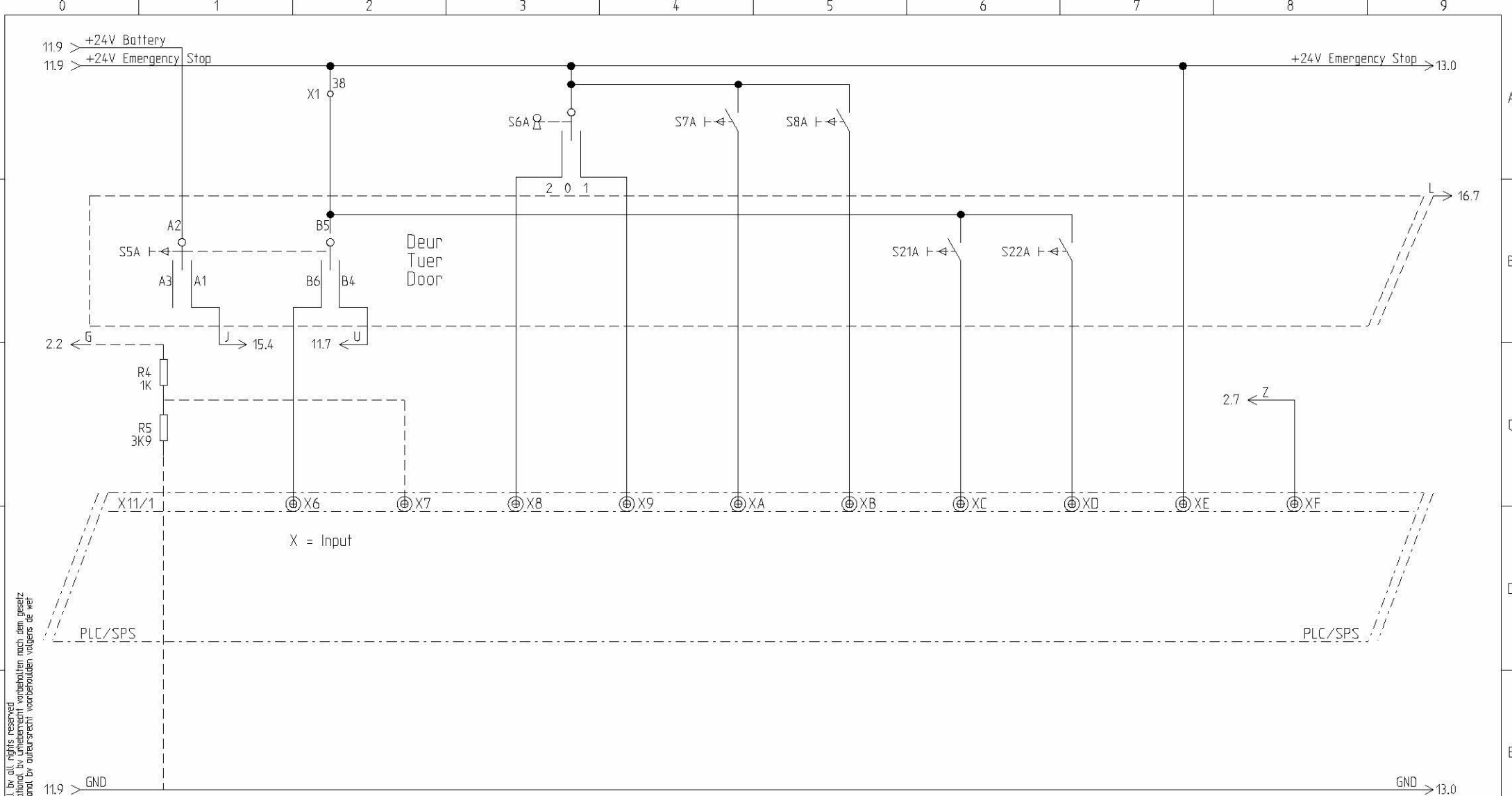

This drawing is property of Holland Lift International. By all rights reserved.  
 deze tekening is eigendom van Holland Lift International. Bij auteursrecht voorbehouden volgens de wet.  
 deze tekening is eigendom van Holland Lift International. Bij auteursrecht voorbehouden volgens de wet.

|   |   |                                |  |                 |                         |                      |   |  |               |
|---|---|--------------------------------|--|-----------------|-------------------------|----------------------|---|--|---------------|
| Dalen Onderwagen<br>Senken Chassis<br>Lift Down Chassis | Heffen – Dalen<br>Heben – Senken<br>Lift Up – Lift Down | W+ Dieselmotor<br>Optie/Option | Progr. Uif<br>Progr. Aus<br>Progr. Off | Aan<br>An<br>On | Store<br>Store<br>Store | Save<br>Save<br>Save | Start – Motor – Stop<br>Start – Motor – Halt<br>Start – Engine – Stop | Overbr. Daalbev<br>Ueberbr. Senkschutz<br>Bridge Lift down protec. | Starterschutz |
|---|---|--------------------------------|--|-----------------|-------------------------|----------------------|---|--|---------------|

——— Overlastin—Ueberlastung—Overload ———



Holland Lift International B.V.  
 Anadeweg 1  
 NL-1627 LJ Haarn The Netherlands  
 T/F +31 (0)229-285555 / 285550  
 E service@hollandlift.com  
 W www.hollandlift.com

SPS Input  
X6 – XF

|                       |                   |           |                              |
|-----------------------|-------------------|-----------|------------------------------|
| Projekt:<br>EY-20-001 | Zeichnungsnummer: | Rev.:     | erstellt von:<br>Rothenbusch |
| Datum:<br>10.04.2012  | Anlage:<br>=      | Ort:<br>+ | Blatt:<br>12                 |

This drawing is property of Holland Lift International. By all rights reserved.  
 deze tekening is eigendom van Holland Lift International. By auteursrecht voorbehouden volgens de wet.  
 deze tekening is eigendom van Holland Lift International. By auteursrecht voorbehouden volgens de wet.

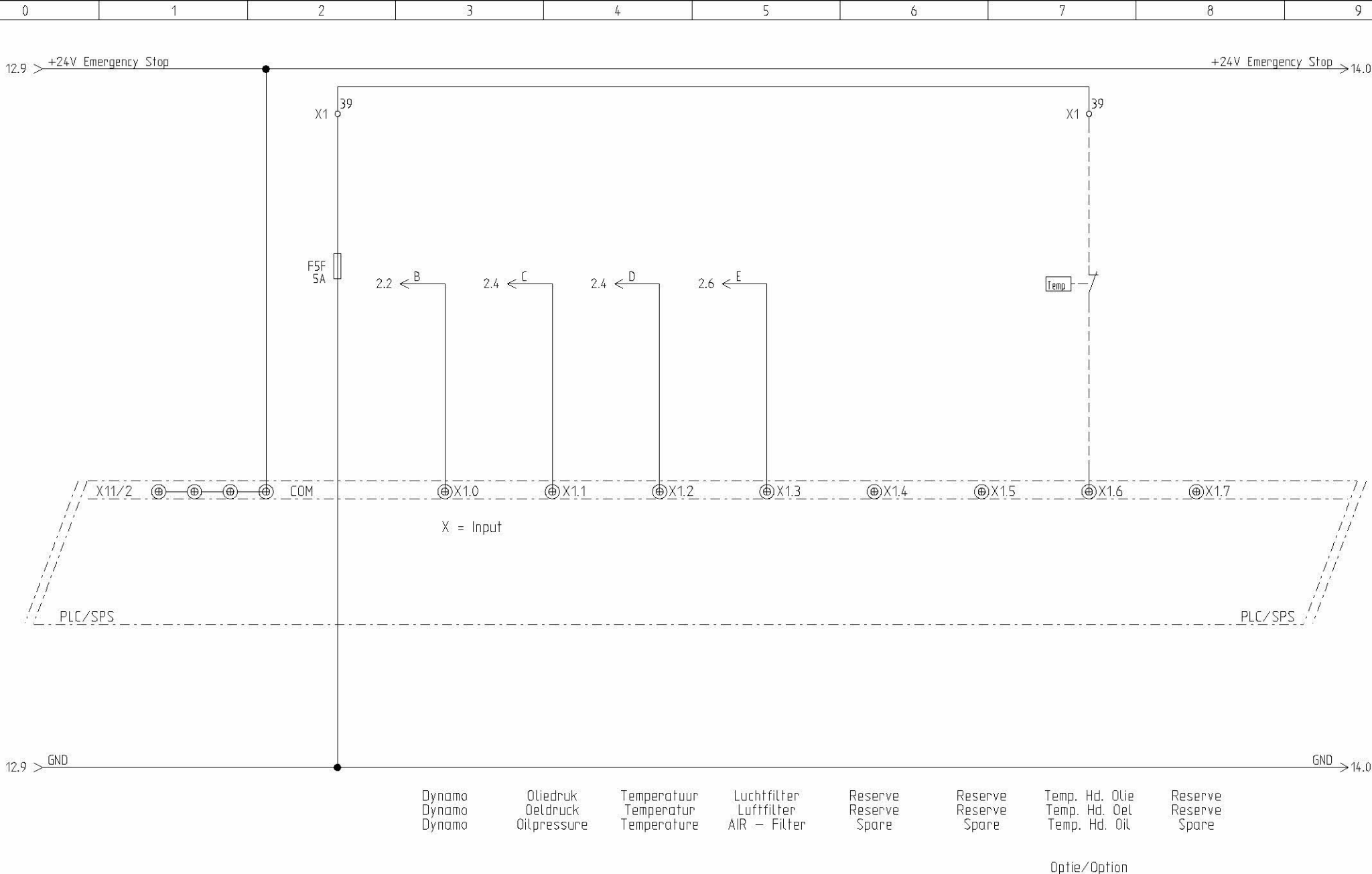

- |        |             |             |              |         |         |                |         |
|--------|-------------|-------------|--------------|---------|---------|----------------|---------|
| Dynamo | Oliedruk    | Temperatuur | Luchtfilter  | Reserve | Reserve | Temp. Hd. Olie | Reserve |
| Dynamo | Oelddruk    | Temperatur  | Luftfilter   | Reserve | Reserve | Temp. Hd. Oel  | Reserve |
| Dynamo | Oilpressure | Temperature | AIR - Filter | Spare   | Spare   | Temp. Hd. Oil  | Spare   |
- Optie/Option



Holland Lift International B.V.  
 Anadeweg 1  
 NL-1627 LJ Haarn The Netherlands  
 T/F +31 (0)229-285555 / 285550  
 E service@hollandlift.com  
 W www.hollandlift.com

SPS Input  
X1.0 - X1.7

|                       |                   |           |                              |
|-----------------------|-------------------|-----------|------------------------------|
| Projekt:<br>EY-20-001 | Zeichnungsnummer: | Rev.:     | erstellt von:<br>Rothenbusch |
| Datum:<br>10.04.2012  | Anlage:<br>=      | Ort:<br>+ | Blatt:<br>13                 |

13.9 > +24V Emergency Stop +24V Emergency Stop > 15.0

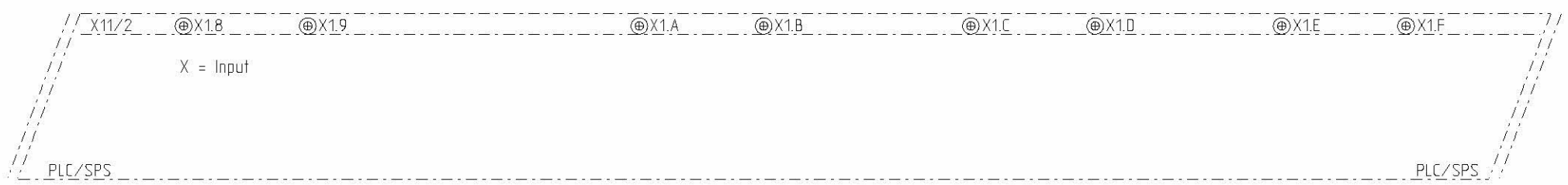

13.9 > GND GND > 15.0

Reserve Spare    Reserve Spare    Reserve Spare    Reserve Spare    Reserve Spare    Reserve Spare    Reserve Spare    Reserve Spare

this drawing is property of Holland Lift International. By all rights reserved.  
 deze tekening is eigendom van Holland Lift International. By all rights reserved.  
 deze tekening is eigendom van Holland Lift International. By all rights reserved.



Holland Lift International B.V.  
 Anadeweg 1  
 NL-1627 LJ Haarn The Netherlands  
 T/F +31 (0)229-285555 / 285550  
 E service@hollandlift.com  
 W www.hollandlift.com

SPS Input  
X1.8 - X1.F

|          |            |                   |       |               |
|----------|------------|-------------------|-------|---------------|
| Projekt: | EY-20-001  | Zeichnungsnummer: | Rev.: | erstellt von: |
| Datum:   | 10.04.2012 | Anlage:           | Ort:  | Rothenbusch   |
|          |            | =                 | +     | Blatt: 14     |

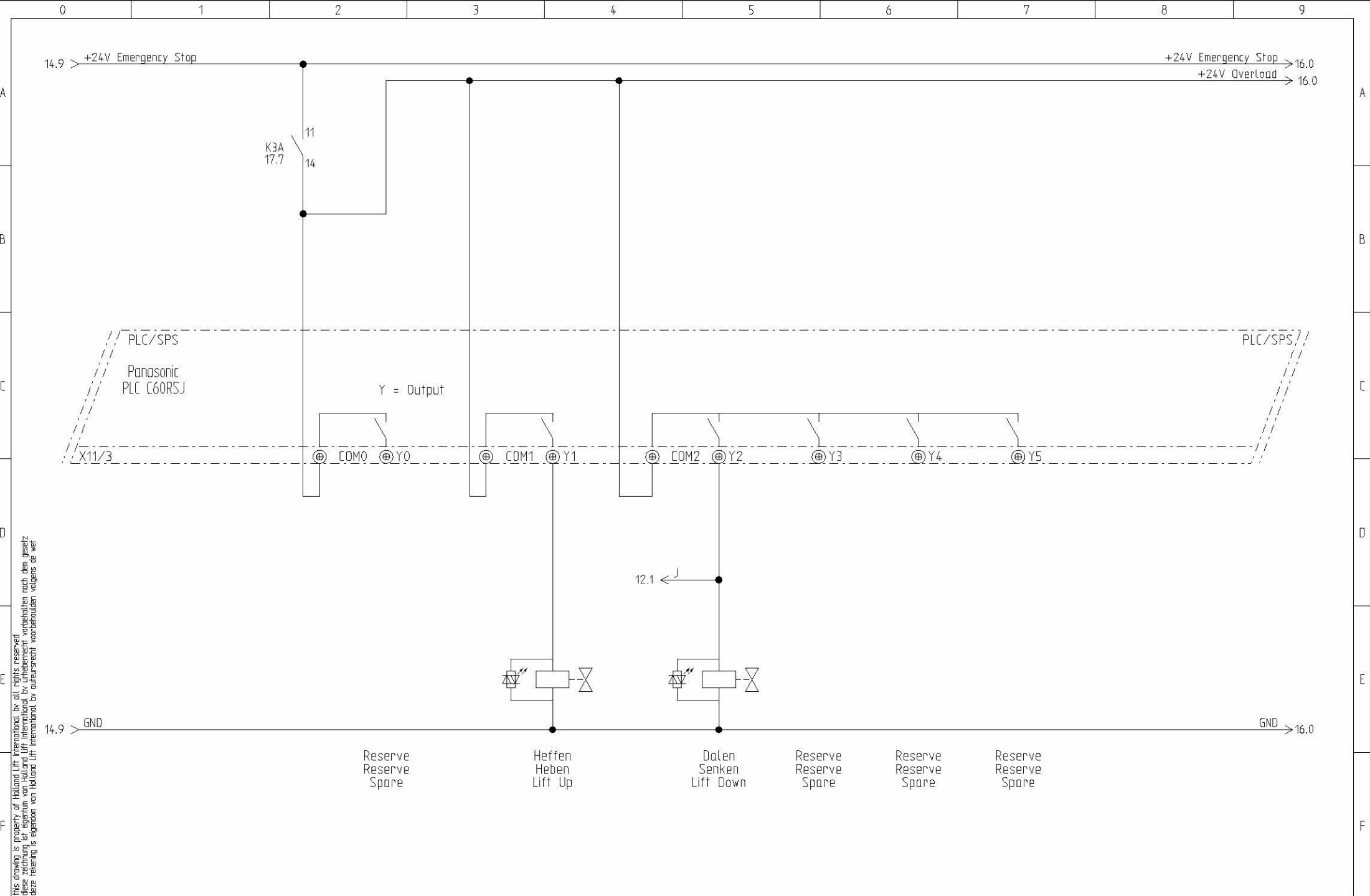

this drawing is property of Holland Lift International, by all rights reserved.  
 deze tekening is eigendom van Holland Lift International, by all rights reserved.  
 deze tekening is eigendom van Holland Lift International, by all rights reserved.



Holland Lift International B.V.  
 Anadeweg 1  
 NL-1627 LJ Haarn The Netherlands  
 T/F +31 (0)229-285555 / 285550  
 E service@hollandlift.com  
 W www.hollandlift.com

SPS Output  
 Y0 - Y5

|          |            |                   |       |               |
|----------|------------|-------------------|-------|---------------|
| Projekt: | EY-20-001  | Zeichnungsnummer: | Rev.: | erstellt von: |
| Datum:   | 10.04.2012 | Anlage:           | Ort:  | Rothenbusch   |
|          |            |                   |       | Blatt:        |
|          |            |                   |       | 15            |

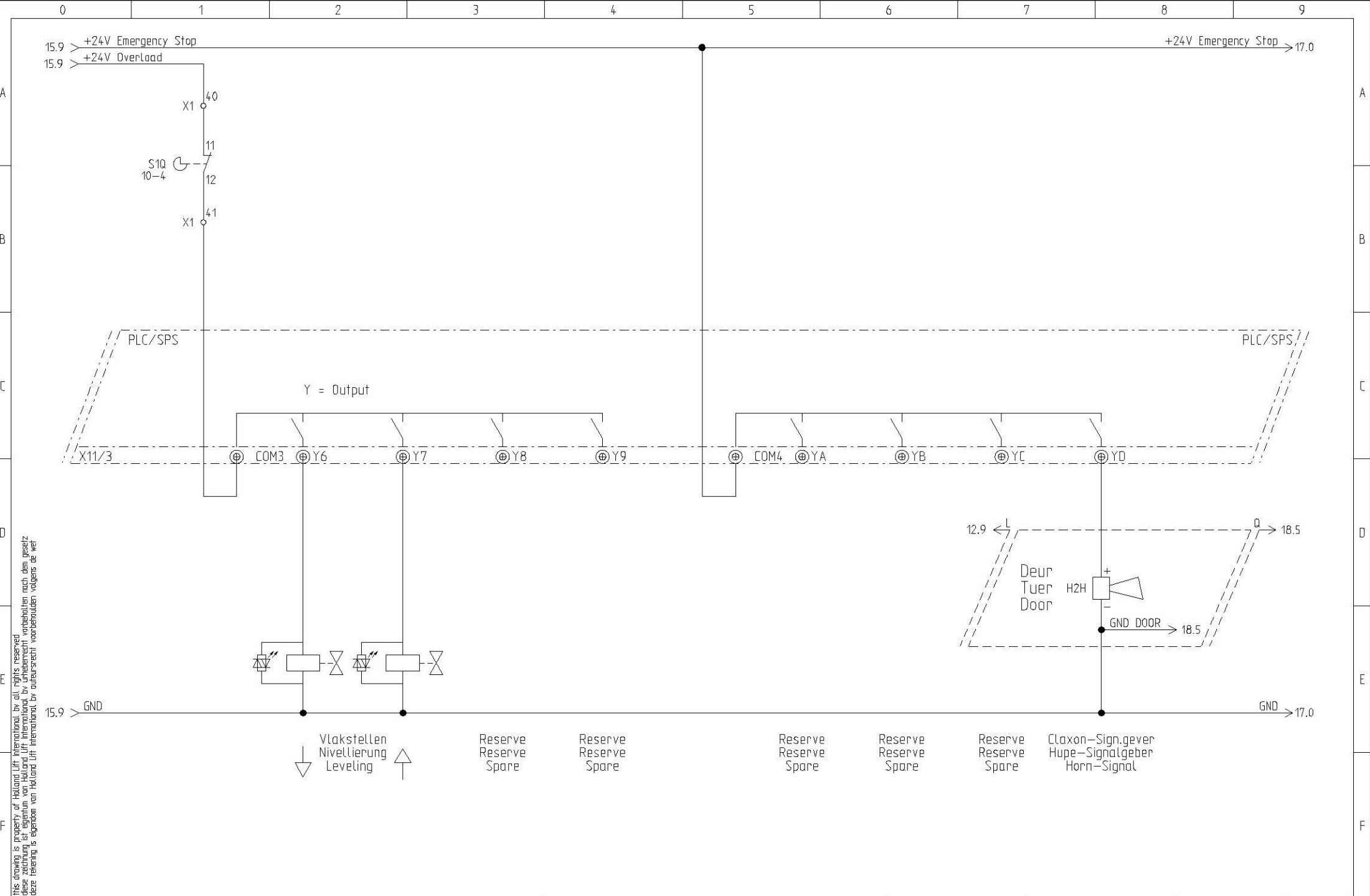

This drawing is property of Holland Lift International. By all rights reserved.  
 deze tekening is eigendom van Holland Lift International. Bij auteursrecht voorbehouden volgens de wet.  
 diese Zeichnung ist Eigentum von Holland Lift International. Bei Urheberrecht vorbehalten.  
 deze tekening is eigendom van Holland Lift International. Bij auteursrecht voorbehouden volgens de wet.



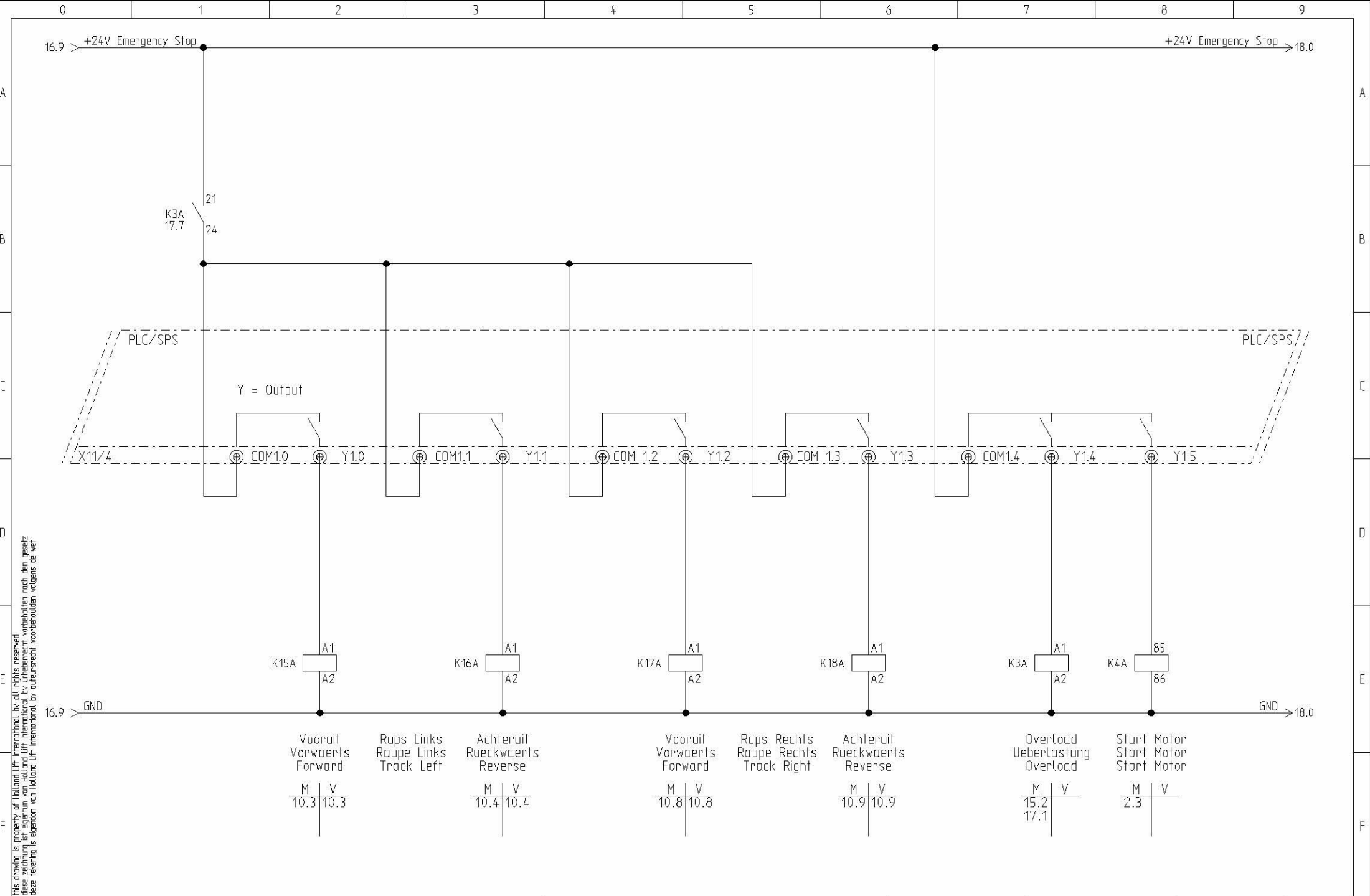

This drawing is property of Holland Lift International. By all rights reserved.  
 deze tekening is eigendom van Holland Lift International. Bij uitsluiting voorbehouden volgens de wet.  
 deze tekening is eigendom van Holland Lift International. Bij uitsluiting voorbehouden volgens de wet.



Holland Lift International B.V.  
 Anadeweg 1  
 NL-1627 LJ Haarn The Netherlands  
 T/F +31 (0)229-285555 / 285550  
 E service@hollandlift.com  
 W www.hollandlift.com

SPS Output  
Y1.0 - Y1.5

|          |            |                   |       |               |
|----------|------------|-------------------|-------|---------------|
| Projekt: | EY-20-001  | Zeichnungsnummer: | Rev.: | erstellt von: |
| Datum:   | 10.04.2012 | Anlage:           | Ort:  | Rothenbusch   |
|          |            |                   |       | Blatt:        |
|          |            |                   |       | 17            |

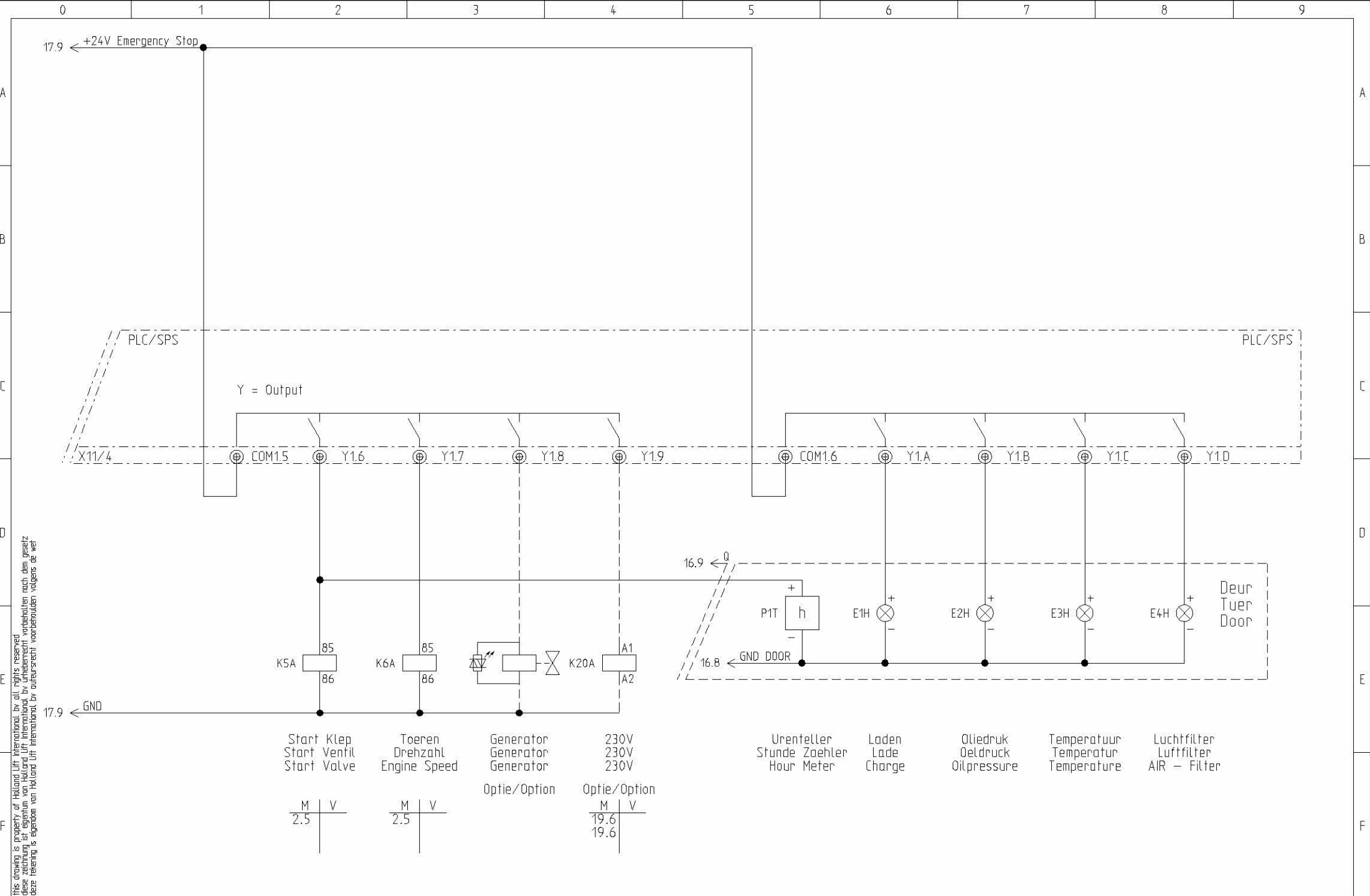

This drawing is property of Holland Lift International. By all rights reserved.  
 deze tekening is eigendom van Holland Lift International. Bij uitsluitend voorbehouden volgens de wet.  
 deze tekening is eigendom van Holland Lift International. Bij uitsluitend voorbehouden volgens de wet.



Holland Lift International B.V.  
 Anadeweg 1  
 NL-1627 LJ Haarn The Netherlands  
 T/F +31 (0)229-285555 / 285550  
 E service@hollandlift.com  
 W www.hollandlift.com

SPS Output  
 Y1.6 - Y1.D

Projekt: EY-20-001  
 Datum: 10.04.2012

Zeichnungsnummer:  
 Anlage: =

Rev.:  
 Ort: +

erstellt von: Rothenbusch  
 Blatt: 18

OPTIES  
OPTIONEN  
OPTIONS

230V AANSLUITING PLATFORM  
230V ANSCHLUSS PLATTFORM  
230V SUPPLY PLATFORM

<230VPLF>

230V-50Hz/115V-50Hz

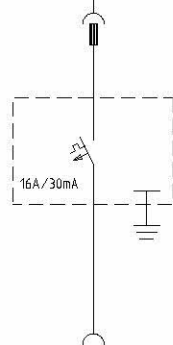

AARDLEKAUTOMAAT  
FI SCHALTER  
EARTH DETECTOR

OPTIE BLACK-BOX MINI DAT  
OPTION BLACK-BOX MINI DAT  
OPTION BLACK-BOX MINI DAT

(HLI)

|       |         |            |            |         |
|-------|---------|------------|------------|---------|
| BB-wf | +24V DC | +24V DC    | +24V DC    | +24V DC |
| BB-bn | GND     | GND        | GND        | GND     |
| BB-gl | CH1     | IN BEDRIJF | IN BETRIEB | RUNNING |
| BB-gs | CH2     | MOTOR      | MOTOR      | MOTOR   |
| BB-rs | CH3     | HEFFEN     | HEBEN      | LIFT UP |
| BB-bl | CH4     | RIJDEN     | FAHREN     | DRIVING |
| BB-rd | CH5     | RESERVE    | RESERVE    | SPARE   |

230V AANSLUITING PLATFORM  
230V ANSCHLUSS PLATTFORM  
230V SUPPLY PLATFORM

<230V-GEN>

230V-50Hz/115V-50Hz

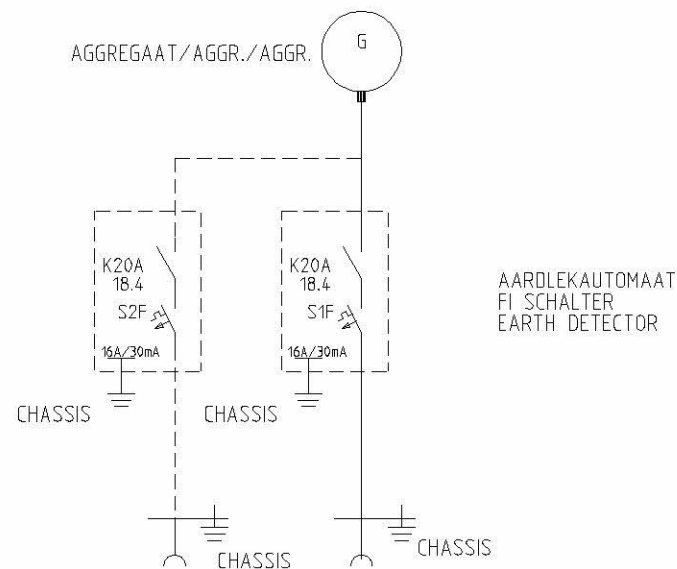

AARDLEKAUTOMAAT  
FI SCHALTER  
EARTH DETECTOR

This drawing is property of Holland Lift International. By all rights reserved.  
 diese Zeichnung ist Eigentum von Holland Lift International. By all rights reserved.  
 deze tekening is eigendom van Holland Lift International. By auteursrecht voorbehouden volgens de wet

**HOLLAND LIFT**

Holland Lift International B.V.  
Anadeweg 1  
NL-1627 LJ Haarn The Netherlands  
T/F +31 (0)229-285555 / 285550  
E service@hollandlift.com  
W www.hollandlift.com

Optionen

Projekt:  
EY-20-001

Zeichnungsnummer:

Rev.:

erstellt von:  
Rothenbusch

Datum:  
10.04.2012

Anlage:

Ort:

Blatt:  
19

# KLEMMENKAST KLEMMENKASTEN CONNECTION BOX

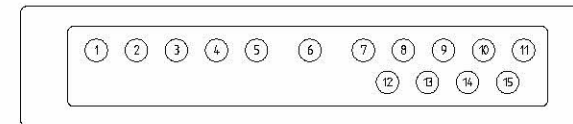
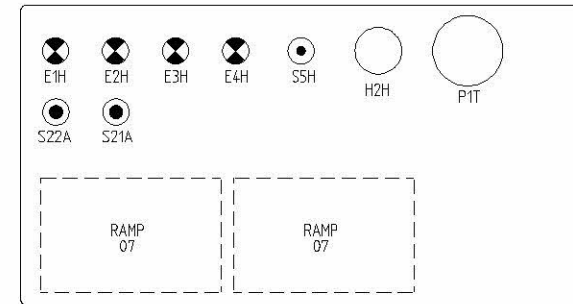
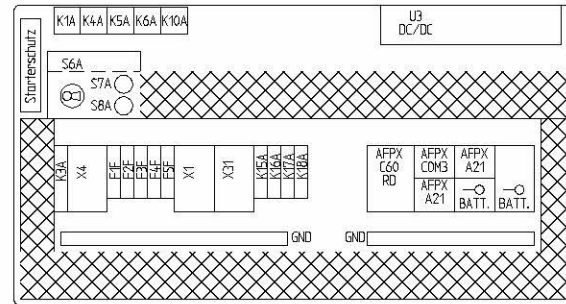

1-5 / 7-15      M20  
6                      Hatz

| WARTEL<br>KABELEINF.<br>GLAND<br>NR. | KLEM<br>KLEMME<br>TERMINAL<br>NR | FUNKTIE                | FUNKTION                    | FUNCTION                |
|--------------------------------------|----------------------------------|------------------------|-----------------------------|-------------------------|
| 1.1                                  | φ 1                              | Voeding +24V           | Speisung +24V               | Power Supply +24V       |
| 1.2                                  | GND                              | Voeding GND            | Speisung GND                | Power Supply GND        |
| 1.3                                  | φ 23                             | + Generator            | + Generator                 | + Generator             |
| 2.1                                  | φ 38 -GND-X4                     | Scheefstand            | Neigung                     | Inclination             |
| 2.2                                  | φ 39 -X1.6                       | Temp. Hd. Olie Opt.    | Temp. Hd. Oel Opt.          | Temp. Hd. Oil Opt.      |
| 3                                    | DIV/VAR                          | 2.5mtr. Afslag S1Q     | 2.5mtr. Ausschaltung S1Q    | 2.5mtr. Cut-out S1Q     |
| 4.1                                  | φ 38 -X2                         | Max. Hoogte Afslag S3Q | Max. Hoehe Ausschaltung S3Q | Max. Height Cut-out S3Q |
| 4.2                                  | Y1-GND                           | Heffen                 | Heben                       | Lift Up                 |
| 5.1                                  | Y2-GND                           | Dalen                  | Senken                      | Lift Down               |
| 5.2                                  | φ 61 -φ 62                       | Rups Links Vooruit     | Raupe Links Vorwaerts       | Track Left Forward      |
| 6                                    | DIV/VAR                          | Diesel                 | Diesel                      | Diesel                  |
| 7.1                                  | φ 63 -φ 64                       | Rups Links Achteruit   | Raupe Links Rueckwaerts     | Track Left Reverse      |
| 7.2                                  | φ 65 -φ 66                       | Rups Rechts Vooruit    | Raupe Rechts Vorwaerts      | Track Right Forward     |
| 8.1                                  | φ 67 -φ 68                       | Rups Rechts Achteruit  | Raupe Rechts Rueckwaerts    | Track Right Reverse     |
| 8.2                                  | Y6-GND                           | Vlakstellen omhoog     | Nivellierung hinauf         | Leveling up             |
| 9                                    | Y7-GND                           | Vlakstellen omlaag     | Nivellierung hinunter       | Leveling down           |
| 10                                   | DIV/VAR                          | Aansl. 6P Platform     | Anschl. 6P Plattform        | Conn. 6P Platform       |
| 11.1                                 | φ 37 -GND-V0                     | Hoekmeting             | Winkel Messung              | Angle Measuring         |
| 11.2                                 | φ 38 -V1                         | Druk Meting            | Druck Messung               | Pressure Measuring      |
| 12.1                                 | Y1.8-GND                         | Hydr. Aggregaat Opt.   | Hydr. Aggr. Opt.            | Hydr. Aggr. Opt.        |
| 12.2                                 | Y1.9-GND                         | Relais Aggregaat Opt.  | Relais Aggr. Opt.           | Relais Aggr. Opt.       |
| 13                                   | RES./SPARE                       |                        |                             |                         |
| 14                                   | RES./SPARE                       |                        |                             |                         |
| 15                                   | RES./SPARE                       |                        |                             |                         |

|   |    | X4 |    |   |    |    | X1      |         |        |        |        | X31 |    |    |    |    |    |    |    |    |    |    |    |    |
|---|----|----|----|---|----|----|---------|---------|--------|--------|--------|-----|----|----|----|----|----|----|----|----|----|----|----|----|
|   |    | 2  | 4  | 5 | 7  | 22 | 31      | 32      | 33     | 37     | 38     | 38  | 38 | 39 | 40 | 61 | 62 | 63 | 64 |    |    |    |    |    |
| 1 | 23 |    |    |   |    |    |         |         |        |        |        |     |    |    |    |    |    |    |    |    |    |    |    |    |
|   |    | 14 | 17 | 3 | 18 | 24 | F1F 20A | F2F 20A | F3F 5A | F4F 5A | F5F 5A | 34  | 35 | 36 | 37 | 38 | 38 | 39 | 41 | 65 | 66 | 67 | 68 |    |
| 1 | 23 |    |    |   |    |    |         |         |        |        |        | 34  | 35 | 36 | 37 | 38 | 38 | 39 | 41 | 65 | 66 | 67 | 68 |    |
|   |    | 2  | 4  | 5 | 7  | 22 |         |         |        |        |        | 31  | 32 | 33 | 37 | 38 | 38 | 38 | 39 | 40 | 61 | 62 | 63 | 64 |

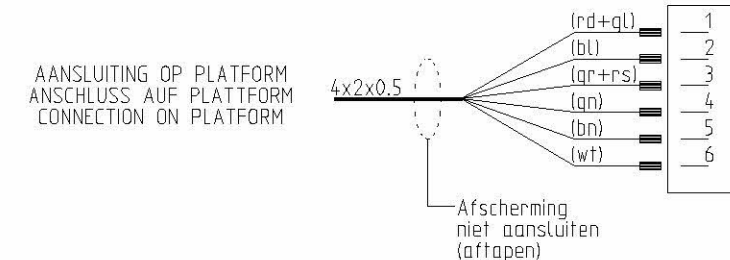

This drawing is property of Holland Lift International. All rights reserved.  
 deze tekening is eigendom van Holland Lift International. Alle rechten voorbehouden.  
 deze tekening is eigendom van Holland Lift International. Alle rechten voorbehouden.



Holland Lift International B.V.  
 Anadeweg 1  
 NL-1627 LJ Haarn The Netherlands  
 T/F +31 (0)229-285555 / 285550  
 E service@hollandlift.com  
 W www.hollandlift.com

Kosten/Bekabeling  
 Kosten/Bekabelung  
 Boxes/Cables

|          |            |                   |   |       |            |               |             |
|----------|------------|-------------------|---|-------|------------|---------------|-------------|
| Projekt: | EY-20-001  | Zeichnungsnummer: |   | Rev.: | 27.06.2012 | erstellt von: | Rothenbusch |
| Datum:   | 10.04.2012 | Anlage:           | = | Ort:  | +          | Blatt:        | 20          |

# BEDIENINGSKAST STEUERPULT CONTROL BOX

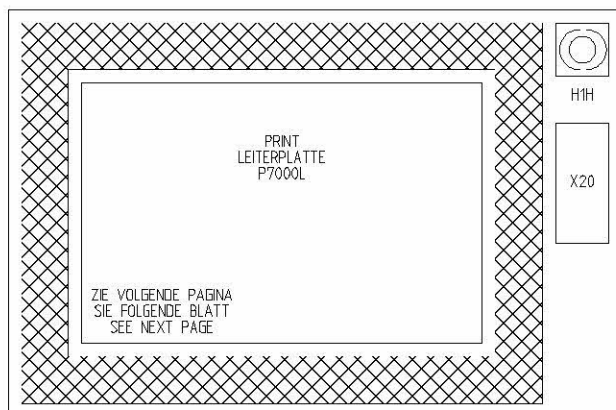
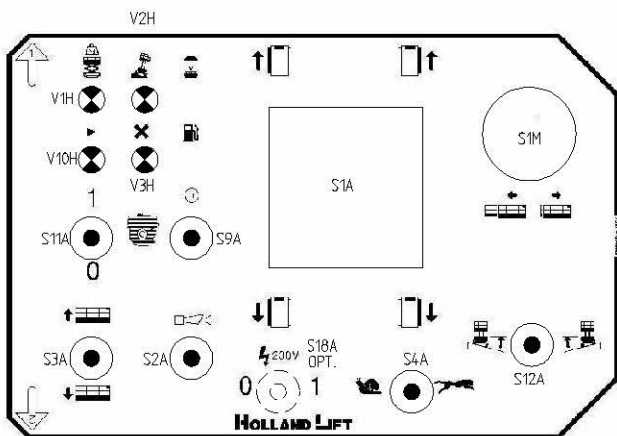

| Colour schedule |         |         |         |
|-----------------|---------|---------|---------|
| Colour          | Dutch   | English | Deutsch |
| Rd              | Rood    | Red     | Rot     |
| Bl              | Blauw   | Blue    | Blau    |
| Gl              | Geel    | Yellow  | Gelb    |
| Gn              | Groen   | Green   | Gruen   |
| Zw              | Zwart   | Black   | Schwarz |
| Wt              | Wit     | White   | Weiss   |
| Bn              | Bruin   | Brown   | Braun   |
| Rs              | Roze    | Pink    | Rosa    |
| Or              | Oranje  | Orange  | Orange  |
| Ps              | Paars   | Violet  | Violett |
| Tp              | Transp. | Transp. | Transp. |
| Gs              | Grijs   | Grey    | Grau    |

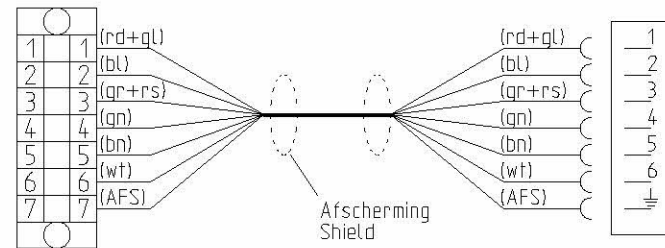

this drawing is property of Holland Lift International, by all rights reserved  
 deze tekening is eigendom van Holland Lift International, by all rights reserved  
 deze tekening is eigendom van Holland Lift International, by all rights reserved

# HOLLAND LIFT

Holland Lift International B.V.  
 Anadeweg 1  
 NL-1627 LJ Haarn The Netherlands  
 T/F +31 (0)229-285555 / 285550  
 E service@hollandlift.com  
 W www.hollandlift.com

Kasten/Bekabelung  
 Kasten/Bekabelung  
 Boxes/Cables

Projekt:  
 EY-20-001

Zeichnungsnummer:

Rev.:

erstellt von:  
 Rothenbusch

Datum:  
 10.04.2012

Anlage:

Ort:

Blatt:  
 21

PRINTPLAAT  
LEITERPLATTE  
CIRCUIT BOARD

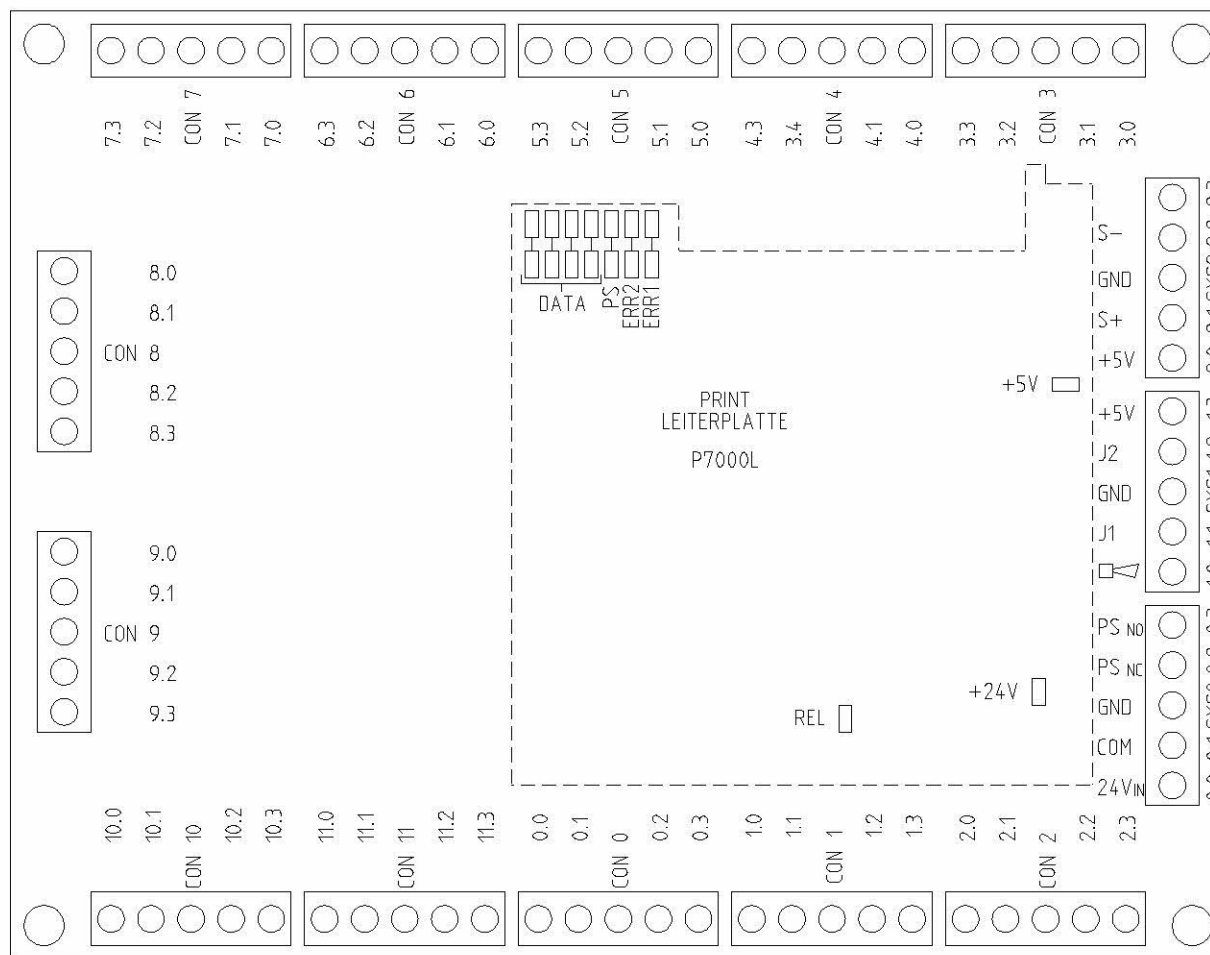

|      |                          |                   |                         |                           |                      |
|------|--------------------------|-------------------|-------------------------|---------------------------|----------------------|
| +24V | <input type="checkbox"/> | Groen/Gruen/Green | Voeding Ok              | Speisung Ok               | Supply Ok            |
| +5V  | <input type="checkbox"/> | Groen/Gruen/Green | Voeding Ok              | Speisung Ok               | Supply Ok            |
| REL  | <input type="checkbox"/> | Groen/Gruen/Green | Power Safe aan          | Power Safe an             | Power Safe on        |
| PS   | <input type="checkbox"/> | Geel/Gelb/Yellow  | Power Safe uit          | Power Safe aus            | Power Safe off       |
| Err1 | <input type="checkbox"/> | Geel/Gelb/Yellow  | Slechte Data Verbinding | Schlechte Data Verbindung | Poor Data Connection |
| Err2 | <input type="checkbox"/> | Rood/Rot/Red      | Geen Data Verbinding    | Keine Data Verbindung     | No Data Connection   |

This drawing is property of Holland Lift International. By all rights reserved.  
 deze tekening is eigendom van Holland Lift International. Bij auteursrecht voorbehouden volgens de wet.  
 deze Zeichnung ist Eigentum von Holland Lift International. Bei auteursrecht voorbehouden volgens de wet.

# HOLLAND LIFT

Holland Lift International B.V.  
 Anadeweg 1  
 NL-1627 LJ Haarn The Netherlands  
 T/F +31 (0)229-285555 / 285550  
 E service@hollandlift.com  
 W www.hollandlift.com

Printplaat  
 Leiterplatte  
 Circuit Board

Projekt:  
 EY-20-001

Zeichnungsnummer:

Rev.:

erstelt von:  
 Rothenbusch

Datum:  
 10.04.2012

Anlage:

Ort:

Blatt:  
 22

|       |                         |                         |                        |
|-------|-------------------------|-------------------------|------------------------|
| 0.0   | Rups Li. Voor. (S1A3)   | Raupe Li. Vor. (S1A3)   | Track Left For. (S1A3) |
| 0.1   | Rups Li. Achter. (S1A4) | Raupe Li. Rueck. (S1A4) | Track Left Rev. (S1A4) |
| CON 0 |                         |                         |                        |
| 0.2   | Rups Re. Voor. (S1A5)   | Raupe Re. Vor. (S1A5)   | Track Ri. For. (S1A5)  |
| 0.3   | Rups Re. Achter (S1A6)  | Raupe Re. Rueck. (S1A6) | Track Ri. Rev. (S1A6)  |

|       |               |               |                  |
|-------|---------------|---------------|------------------|
| 1.0   | Claxon (S2A1) | Hupe (S2A1)   | Horn (S2A1)      |
| 1.1   | Reserve       | Reserve       | Spare            |
| CON 1 |               |               |                  |
| 1.2   | Heffen (S3A1) | Heben (S3A1)  | Lift Up (S3A1)   |
| 1.3   | Dalen (S3A2)  | Senken (S3A2) | Lift Down (S3A2) |

|       |                     |                       |                     |
|-------|---------------------|-----------------------|---------------------|
| 2.0   | Snel Rijden (S4A1)  | Schnell Fahren (S3A1) | Driving Fast (S3A1) |
| 2.1   | Toerental (S9A)     | Drehzahl (S9A)        | Enging Speed (S9A)  |
| CON 2 |                     |                       |                     |
| 2.2   | Langzaam Ri. (S4A2) | Langsam Fahren (S4A2) | Driving Slow (S4A1) |
| 2.3   | Reserve             | Reserve               | Spare               |

|          |                    |                     |                   |
|----------|--------------------|---------------------|-------------------|
| 0.0      | Voeding +24V (S1M) | Speisung +24V (S1M) | Supply +24V (S1M) |
| 0.1      | Voeding +24V (S1M) | Speisung +24V (S1M) | Supply +24V (S1M) |
| SYS0 GND | GND                | GND                 | GND               |
| 0.2      | Reserve            | Reserve             | Spare             |
| 0.3      | Voeding +24V (PS)  | Speisung +24V (PS)  | Supply +24V (PS)  |

|          |                       |                        |                      |
|----------|-----------------------|------------------------|----------------------|
| 1.0      | + Zoemer (H1H)        | + Summer (H1H)         | + Buzzer (H1H)       |
| 1.1      | 0-5V Joystick P1      | 0-5V Joystick P1       | 0-5V Joystick P1     |
| SYS1 GND | - Zoemer (H1H)        | - Summer (H1H)         | - Buzzer (H1H)       |
| 1.2      | Reserve (0-5V)        | Reserve (0-5V)         | Spare (0-5V)         |
| 1.3      | Voeding +5V Joy. (P1) | Speisung +5V Joy. (P1) | Supply +5V Joy. (P1) |

|          |                 |                 |                 |
|----------|-----------------|-----------------|-----------------|
| 2.0      | Reserve (+5V)   | Reserve (+5V)   | Spare (+5V)     |
| 2.1      | Data S+ (RS485) | Data S+ (RS485) | Data S+ (RS485) |
| SYS2 GND | Reserve         | Reserve         | Spare           |
| 2.2      | Data S- (RS485) | Data S- (RS485) | Data S- (RS485) |
| 2.3      | Reserve         | Reserve         | Spare           |

|       |                      |                         |                   |
|-------|----------------------|-------------------------|-------------------|
| 3.0   | Dodemansknopt (S1A1) | Totmansknopt (S1A1)     | Dead Man (S1A1)   |
| 3.1   | Dodemansknopt (S1A2) | Totmansknopt (S1A2)     | Dead Man (S1A2)   |
| CON 3 |                      |                         |                   |
| 3.2   | Vlak. omhoog (S12A1) | Nivel. hinauf (S12A1)   | Lev. up (S12A1)   |
| 3.3   | Vlak. omlaag (S12A2) | Nivel. hinunter (S12A2) | Lev. down (S12A2) |

|       |         |         |       |
|-------|---------|---------|-------|
| 4.0   | Reserve | Reserve | Spare |
| 4.1   | Reserve | Reserve | Spare |
| CON 4 |         |         |       |
| 4.2   | Reserve | Reserve | Spare |
| 4.3   | Reserve | Reserve | Spare |

|       |                   |                    |                   |
|-------|-------------------|--------------------|-------------------|
| 5.0   | Reserve           | Reserve            | Spare             |
| 5.1   | Overload (V1H)    | Ueberlastung (V1H) | Overload (V1H)    |
| CON 5 |                   |                    |                   |
| 5.2   | Scheefstand (V2H) | Neigung (V2H)      | Inclination (V2H) |
| 5.3   | Reserve           | Reserve            | Spare             |

|       |                       |                       |                       |
|-------|-----------------------|-----------------------|-----------------------|
| 6.0   | Start Motor (S11A1)   | Start Motor (S11A1)   | Start Engine (S11A1)  |
| 6.1   | Stop Motor (S11A2)    | Halt Motor (S11A2)    | Stop Engine (S11A2)   |
| CON 6 |                       |                       |                       |
| 6.2   | Gen. aan Opt. (S18A1) | Gen. an Opt. (S18A1)  | Gen. on Opt. (S18A1)  |
| 6.3   | Gen. uit Opt. (S18A2) | Gen. aus Opt. (S18A2) | Gen. off Opt. (S18A2) |

|       |                         |                          |                         |
|-------|-------------------------|--------------------------|-------------------------|
| 7.0   | Vlak. Ok (V11H1) Opt.   | Nivel. Ok (V11H1) Opt.   | Lev. Ok (V11H1) Opt.    |
| 7.1   | Vlak. Fout (V11H2) Opt. | Nivel. Fal. (V11H2) Opt. | Lev. Fault (V11H2) Opt. |
| CON 7 |                         |                          |                         |
| 7.2   | Reserve                 | Reserve                  | Spare                   |
| 7.3   | Reserve                 | Reserve                  | Spare                   |

|       |         |         |       |
|-------|---------|---------|-------|
| 8.0   | Reserve | Reserve | Spare |
| 8.1   | Reserve | Reserve | Spare |
| CON 8 |         |         |       |
| 8.2   | Reserve | Reserve | Spare |
| 8.3   | Reserve | Reserve | Spare |

|       |         |         |       |
|-------|---------|---------|-------|
| 9.0   | Reserve | Reserve | Spare |
| 9.1   | Reserve | Reserve | Spare |
| CON 9 |         |         |       |
| 9.2   | Reserve | Reserve | Spare |
| 9.3   | Reserve | Reserve | Spare |

|        |                        |                         |                        |
|--------|------------------------|-------------------------|------------------------|
| 10.0   | In Bedrijf (V10H)      | In Betrieb (V10H)       | Run (V10H)             |
| 10.1   | Storing Dieselm. (V3H) | Stoerung Dieselm. (V3H) | Failure Dieselm. (V3H) |
| CON 10 |                        |                         |                        |
| 10.2   | Reserve                | Reserve                 | Spare                  |
| 10.3   | Reserve                | Reserve                 | Spare                  |

|        |         |         |       |
|--------|---------|---------|-------|
| 11.0   | Reserve | Reserve | Spare |
| 11.1   | Reserve | Reserve | Spare |
| CON 11 |         |         |       |
| 11.2   | Reserve | Reserve | Spare |
| 11.3   | Reserve | Reserve | Spare |

This drawing is property of Holland Lift International. In all rights reserved.  
 deze tekening is eigendom van Holland Lift International. In alle rechten voorbehouden.  
 diese zeichnung ist eigentum von Holland Lift International. In alle rechte vorbehalten.  
 deze tekening is eigendom van Holland Lift International. In alle rechten voorbehouden.



Holland Lift International B.V.  
 Anadeweg 1  
 NL-1627 LJ Haarn The Netherlands  
 T/F +31 (0)229-285555 / 285550  
 E service@hollandlift.com  
 W www.hollandlift.com

Printplaat  
 Leiterplatte  
 Circuit Board

|          |            |                   |   |       |   |              |             |
|----------|------------|-------------------|---|-------|---|--------------|-------------|
| Projekt: | EY-20-001  | Zeichnungsnummer: |   | Rev.: |   | erstelt von: | Rothenbusch |
| Datum:   | 10.04.2012 | Anlage:           | = | Ort:  | + | Blatt:       | 23          |